

DESCRIPTION

AND

RULES FOR THE MANAGEMENT

OF THE

U. S. MAGAZINE RIFLE

AND

CARBINE.

---

CALIBER .30.

---



WASHINGTON:  
GOVERNMENT PRINTING OFFICE.  
1894.

## U. S. MAGAZINE RIFLE AND CARBINE, MODEL 1892.

---

The adoption of this rifle and carbine for Army use was the result of a long series of tests of arms presented to a board of officers, appointed by General Orders, No. 136, Headquarters of the Army, Adjutant-General's Office, November 24, 1890, to "consider and recommend a suitable magazine system for rifles and carbines for the military service."

The composition of the board was changed by several subsequent orders. Its members, at the date of the final report, were:

Lieut. Col. R. H. HALL, Sixth Infantry.

Lieut. Col. J. P. FARLEY, Ordnance Department.

Maj. H. B. FREEMAN, Sixteenth Infantry.

Capt. S. E. BLUNT, Ordnance Department, recorder.

Capt. G. S. ANDERSON, Sixth Cavalry.

The board in its report of August 19, 1892, recommended the arm now known as the U. S. magazine rifle, model 1892. This action was approved by the Secretary of War on September 15, 1892.

The details of caliber, rifling, bayonet, sights, and other minor parts, and ammunition adopted, were recommended by a board of ordnance officers appointed by the War Department September 22, 1892.

Fig. 1.

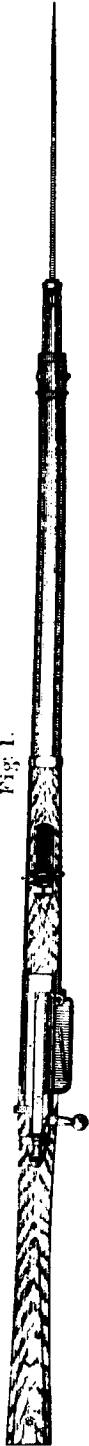
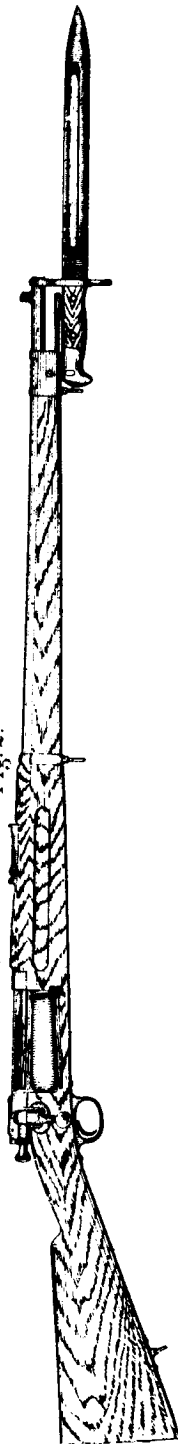

Fig. 2.



## U. S. MAGAZINE RIFLE AND CARBINE (CALIBER .30), MODEL 1892.

---

These arms belong to that class of magazine arms in which the magazine of the fixed type is located centrally or at the rear of the barrel. It is horizontal, lying below and also at the left of the receiver.

They can be used, *first*, as a magazine arm, the cartridges for each five being fed only from the magazine, which is recharged when entirely or when partly emptied; *second*, as a single loader, with magazine ignored and not charged; *third*, as a single loader, with magazine charged but held in reserve by the cut-off. The construction of the arm permits the magazine to be loaded when empty or when partly full and without regard to the position of the bolt or cut-off.

The rifle is provided with a knife bayonet attachable to the barrel and the under side of the front band. The rifle, with bayonet fixed, is represented, one-eighth size, in fig. 1, top view; fig. 2, right side. The length of the bayonet is 16.30 inches; of the rifle, 49.14 inches; of the rifle with bayonet fixed, 60.79 inches.

## DESCRIPTION AND NOMENCLATURE.

## RIFLE.

The principal parts of the rifle are the *barrel*, the *breech mechanism*, the *magazine mechanism*, the *trigger and sear*, the *sights*, the *stock and hand guard*, the *mountings*, and the *bayonet*.

The *barrel complete* includes the *barrel proper*, the *front sight* and its *stud* and *pin*, the *rear sight* complete, and the *receiver*. Its entire length is 37.41 inches. It is represented in fig. 3, one-seventh size. The parts are A, *barrel proper*; R, *receiver*; C, *rear sight* with leaf raised.

Fig. 4 represents the *barrel proper*, one-seventh size, with *rear sight* with leaf down. The parts are M, *muzzle*; B, *front sight*, *front sight stud* and *pin*; C, *rear sight* with leaf down; D, *screw thread*, by which the barrel is connected with the receiver; E, *blank tenon*, whose face forms the front of the space for the cartridge head.

The length of the barrel is 30 inches. The rifling consists of four plain concentric grooves three times the width of the lands and 0.004" deep, with a uniform twist of one turn in 10 inches. The rear part of the bore, called the chamber, is represented in section in fig. 5, full size. It is 2.33" in length, and is made slightly conical to facilitate the withdrawal of the cartridge case. There are also two contractions, the rear one, A, corresponding to the neck of the cartridge or the front of the powder space and the position of the base of the bullet, and the forward one, B, corresponding to the line of juncture of the cartridge case and bullet, and called the *throat*. The grooves start at about the middle of the throat. On the end of the barrel, over the rear of the chamber, a small slot, C, is cut for the reception of the hook of the extractor.

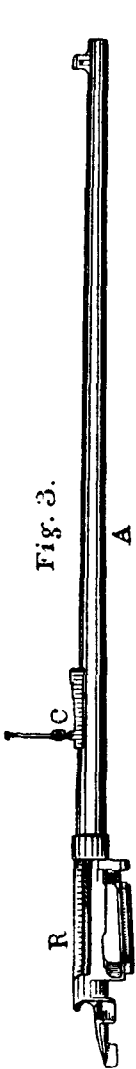
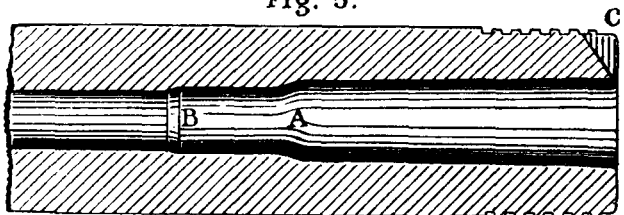

Fig. 5.



The breech mechanism consists principally of the *receiver, bolt, sleeve, cocking piece, firing pin, striker, main spring, extractor, ejector, and safety lock.*

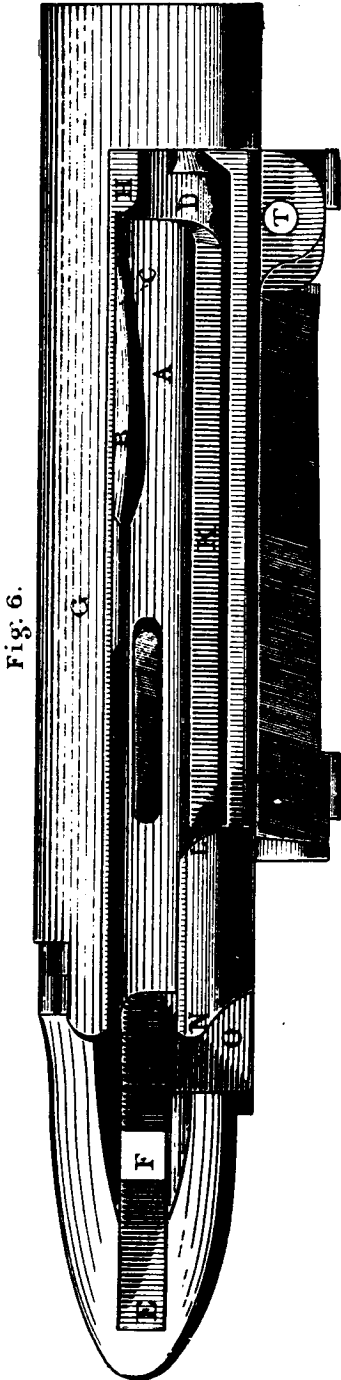

Fig. 6.

The receiver, shown seven-eighths size in fig. 6, top view; fig. 7, right side; fig. 8, left side, is forged in one piece with the magazine. It is bored through longitudinally for the reception of the bolt, and is also cut away on the right and partly on top to facilitate ejection of the empty cartridge case and the use of the arm as a single loader. The *floor, A*, affords a smooth surface on which cartridges may be placed when using the arm in the latter manner. It is not necessary to directly introduce them into the chamber, as they will be pushed there by the bolt in its forward motion. At the left of the floor is the *magazine channel, B*, of less width at the rear than at the front, along and through which the cartridges pass from the magazine to the receiver and chamber. The *ramp, C*, at the front end directs the point of the bullet. On the bottom of the floor at the front is the *locking recess, D*, with its cam and shoulder; further to the rear, the *ejector cut* for the reception of the ejector; and in the tang a channel, *E*, for the cocking piece, and a cut, *F*, for the nose of the sear. The *left wall, G*, of the receiver is continuous; it aids in guiding the direct motion of the bolt. The extractor spring engages under the lip, *H*, when the bolt is closed. A groove in this wall contains the cut-off spindle; the freeing cut, *I*, at the rear, permits passage of the handle collar of the bolt as the latter is closed. On the right wall of the receiver is the *guide rail, K*, on which the guide rib of the bolt rests when closed and along which the locking lug moves in the direct motion of the bolt until limited by the locking shoulder and cam, *L*. This latter portion of the right wall, *L, N*, bears against the sleeve and extractor, preventing their rotation with the bolt; its front surface, *L*, the *locking shoulder*, and rear surface, *N*, the *extracting*

shoulder, are helicoidal, and affording a bearing for the rear of the guide rib and the base of the handle as the bolt is turned down and up, produce a slight direct motion forward and to the rear of the bolt. Back

Fig. 7.

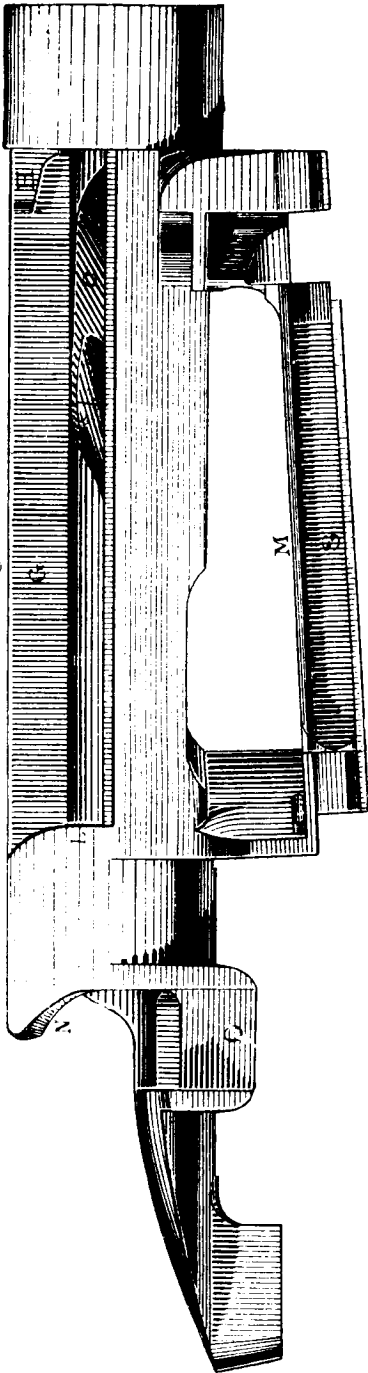
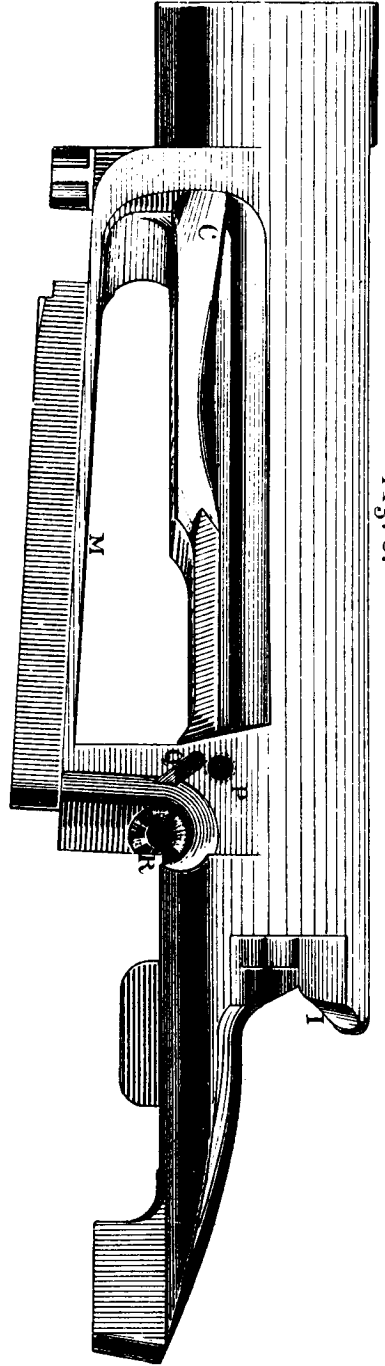

Fig. 8.



of this part of the right wall a recess, O, is made for the handle body when the bolt is closed. The forward end of the receiver is tapped for the reception of the barrel and a cut made, corresponding to that in the barrel, for the front of the extractor. Other parts of the receiver are the side plate screw hole, P, the ejector pin hole, Q, and the sear seat, R. On the under side of the end of the tang and of the rear of the magazine floor are the guard screw holes and the trigger seat. Other parts of the combined receiver and magazine are mentioned under the head of "Magazine."

Fig. 9 represents the *bolt*, side view; fig. 10, rear view; fig. 11, front view, all three-quarter size. The bolt, generally cylindrical in shape, is operated by the *handle*, H, whose base, extending over the bolt at the rear, forms the *handle collar*, C, which serves as one of the connections of the bolt and sleeve. The front surface of the collar is undercut, thus strengthening the connection of bolt and sleeve and the projecting arm of the latter. One corner of the handle near the base is slightly curved and bears against the extracting shoulder, N, fig. 7, on the right wall of the receiver as the bolt is opened, thus inducing its first motion to the rear and starting the empty cartridge case in the chamber. The *guide rib*, B, guides the bolt in its direct motion, and passing between the receiver walls prevents it then turning. Its front end, partly cut away, affords a bearing, when the bolt is fully drawn back, for a shoulder on the under side of the extractor, which prevents further rotation of the bolt until the extractor is lifted. The rear end forms a *locking shoulder*, D, which,

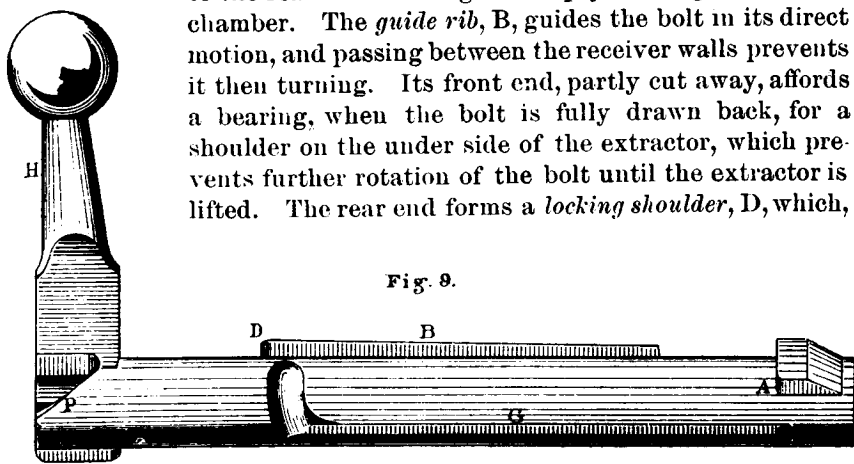

Fig. 9.

bearing against the cam, L, fig. 7, on the right wall of the receiver, gives the first part of the final forward motion of the bolt. It also aids in securing the bolt and the lug in sustaining the shock of discharge. The right hand corner of the *locking lug*, A, is slightly rounded, and engaging against the cam of the recess in the receiver floor gives the final forward motion of the bolt; its rear locking surface is not quite at right angles to the bolt's axis. The ejector groove, G, with its turn, is a freeing cut to admit without action the heel of the ejector. The inclined front end of the groove coming in contact with the heel of the ejector when the bolt is withdrawn causes the point of the ejector to rise, throwing out the empty cartridge case.



The *safety notch*, F, admits the end of the spindle of the safety lock when the latter is turned to the right. The slot, K, admits the securing stud of the sleeve.

The rear of the bolt under the handle is cut away, leaving the *cocking cam*, P, which, with the nose of the cocking piece, produces, as the bolt is turned after discharge, the first portion of the compression of the main spring.

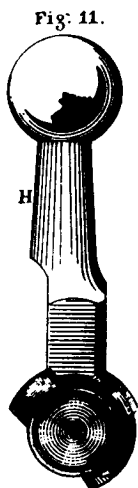
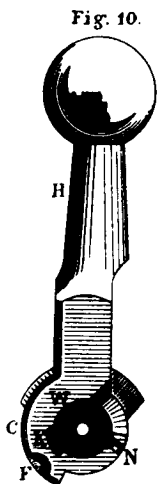

The cocking nose notch, N, when the assembled bolt is withdrawn from the receiver, serves to retain its parts in the relative position they then occupy. The face of the bolt is countersunk, constituting, with the face of the barrel, the counter-bore for the cartridge head; it closes, except for the striker hole, the *bolt well*, W. The well or cavity of the bolt contains the firing pin, striker, and main spring; it is cylindrical, except where contracted at the front end corresponding to the point of the striker. Immediately in rear of this contraction is a small channel to permit issue of gas from the bolt well in case of rupture of a cartridge head or piercing of the primer.

The *sleeve*, fig. 12, side view; fig. 13, rear view, both full size. The extractor arm carries the extractor, whose heel enters the forks, B; C is the extractor screw hole, tapped in the lower arm of the fork for the extractor screw. The projection, D, engages in the undercut groove on the handle collar. The spindle, E, enters the well of the bolt; the

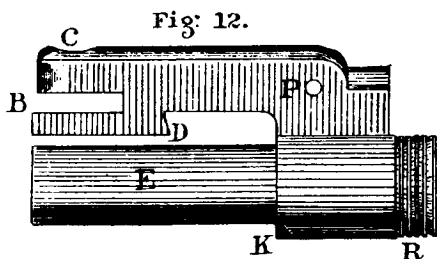

front of the spindle gives a bearing surface to the main spring. The firing pin passes through the well of the spindle; the cocking piece through the well, M, of the sleeve body; the cocking guide, H, directs the movement of the cocking piece and prevents its rotation. The dust space, K, affords clearance for any dust that may have accumulated in the cocking cam recess of the bolt. Other parts are the safety lock

spindle channel, N, the safety lock pin hole, P, and the knurling, R, on the body to afford a firm grasp for the fingers in assembling. The securing stud and its rivet, shown full size in fig. 14, assist in the connection of bolt and sleeve. The stud is permanently riveted in manufacture to the spindle of the sleeve.

The *cocking piece* is represented, full size, in fig. 15, front view; fig. 16, side view. The parts are the body, B; the firing pin hole, A, threaded at the rear for the firing pin; the comb, C, to furnish a secure grasp of the fingers on the cocking piece; the safety notch, D; the cocking nose, E; cocking cam, F; cocking shoulder, H; and the face, K.

Fig. 17.



Fig. 18.



Fig. 15.

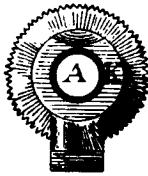
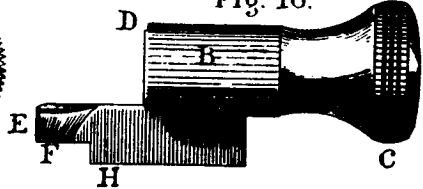

Fig. 16.



The compression of the main spring or the cocking of the rifle is commenced as the bolt is rotated to the left by the action of the cam of the cocking piece in connection with the cam on the rear of the bolt body, and is completed after the shoulder of the cocking piece engages against the nose of the sear as the bolt is turned down and locked. Or when the bolt is closed it can be accomplished directly by grasping the comb and drawing it to the rear until the sear engages on the cocking shoulder.

The *firing pin* is represented, full size, in figs. 17 and 18. The parts are the body, A, which also serves as a spindle for the main spring; the striker joint, B, to which the striker is assembled and whose shape permits ready separation or attachment; and the thread, C. The thread secures the pin to the cocking piece, the length of assembled pin and striker being so adjusted that with the proper projection of the striker point from the face of the bolt the face of the cocking piece shall abut against the rear face of the sleeve spindle; the pin is then riveted to the cocking piece.

The *striker* is represented, full size, in figs. 19 and 20. The parts are A, the point; B, the body, partly cut away to permit the assembling of the firing pin into the joint, C; and the face, D. The face serves as the front bearing for the main spring.

Fig. 19.



Fig. 20.

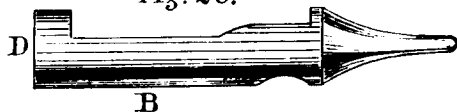

The *main spring* is represented, full size, in fig. 21. When assembled it lies around the firing pin, between the rear face of the striker and the front face of the sleeve spindle.

The *extractor* is shown, full size, in fig. 22, top, and fig. 23, left side. The parts are A, body; B, screw hole; C, hook; D, extractor spring slot; E, hole for extractor spring stud; F, heel. The extractor is a long spring attached at the rear to the sleeve, the hook rising over and engaging upon the cartridge head as the bolt is closed. The heel placed between the forks of the projecting arm of the sleeve is slightly cut away at one side, permitting turning of the extractor to the right, and facilitating withdrawal of the assembled bolt from the receiver. The extractor screw hole is not threaded.

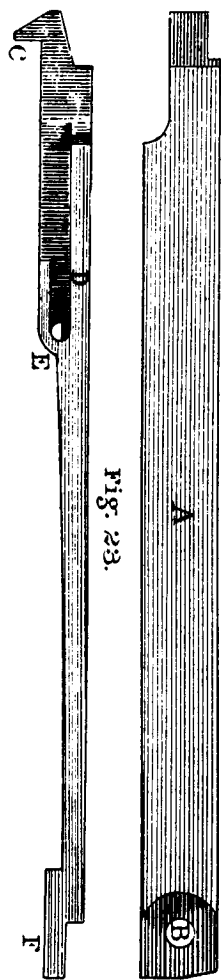

Fig. 22.

Fig. 23.



Fig. 24.

Fig. 21.



The *extractor screw*, fig. 24, full size, connects the extractor to the sleeve. The part passing through the extractor is not threaded, and acts as a pivot for the extractor's lateral movement when assembling.

The *extractor spring* is represented, full size, in fig. 25, top view; fig. 26, right side. The parts are stud, A; body, B; and point, C. The stud and body are placed in the corresponding hole and slot, near the front end of the extractor. The point of the spring as the bolt is closed engages under the lip on the left wall of the receiver and insures the grasp of the extractor hook upon the cartridge head. As the extractor itself generally maintains this grasp, this spring is not essential; it is added merely as a precautionary measure.

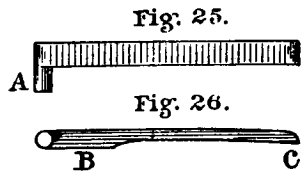

The *ejector* is represented, full size, in fig. 27, top view; fig. 28, side view. The parts are A, heel; B, point; C, pin hole. Lying in a cut in the receiver floor, and being pivoted at the rear of its center of gravity, the forward portion of the ejector is slightly below the level of the receiver floor, being there sustained by the point resting on a shoulder in the cut, while the heel projecting above the floor enters the ejector groove in the bottom and side of the bolt until at the end of the bolt's motion to the rear the end of the groove coming into sudden bearing on the heel operates the ejector and throws out the empty shell.

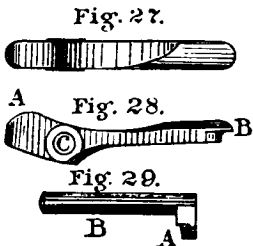

The *ejector pin*, fig. 29, full size, has a head, A, by means of which it can be withdrawn from the receiver; the spindle, B, acts as a hinge for the ejector.

The *safety lock* is represented, full size, in fig. 30, end view; fig. 31, side view. The parts are the thumb piece, A; the body, B; the cocking piece groove, C; the spindle, D; the bolt notch, E; and the pin groove, F. When turned to the left the lock is opened, the bolt notch lying over the handle collar of the bolt, the cocking piece groove over the cocking piece. After the arm is cocked the thumb piece can be turned to the right, closing the lock, when the portion of the point of the spindle not cut away for the bolt notch enters the safety notch in the collar and prevents any movement of the bolt; at the same time the cam, H, slightly retracts the cocking piece, permitting the body of the safety lock to pass before the face of the cocking piece and prevents its forward motion if the sear should be released from the cocking shoulder.

The lock is secured in its channel in the sleeve by the safety lock pin, shown full size in fig. 32, which traverses the groove, F, fig. 31, in the lock spindle.

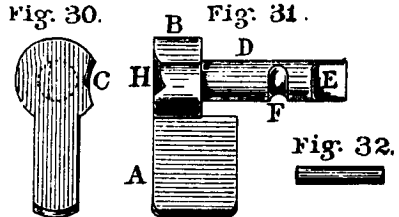

The magazine mechanism consists principally of the *magazine, side plate, gate, hinge pin, magazine spring, carrier, follower, and cut-off*.

The *magazine*, shown seven-eighths size, with the receiver, in figs. 6, 7, and 8, lies below and also at the left of the receiver; the under side of the floor of the receiver forms the top of the magazine, and is partly cut away near the rear to afford space for the cartridge heads; the magazine, closed at the bottom by the floor, M, increases in depth from front to rear to permit reception of the cartridge. The rear wall is vertical, but being inclined to the side causes the the head of each cartridge to lie

Fig. 33

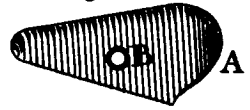

Fig. 34

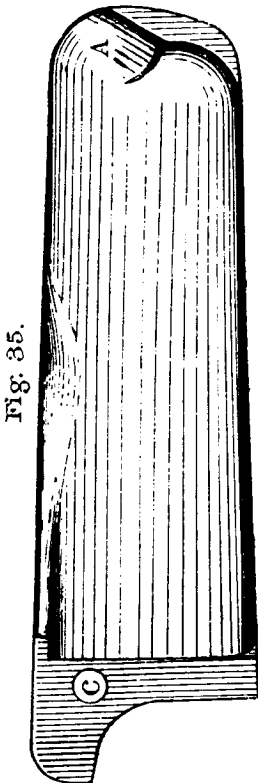
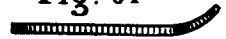

Fig. 35.

Fig. 36.



Fig. 37.



behind that of the cartridge in advance; the front wall, parallel to the rear, is curved, corresponding to the point of the bullet. The groove, S, fig. 7, for the seat of the magazine spring, is at the right of the floor, with holes for the hinge bar at its front and rear. At the front is also the hole, T, fig. 6, and channel for the carrier arbor. On the left, at the front, is a groove for the lip of the side plate. At the rear of the floor is a hole for the guide lip rivet.

The *guide lip*, shown full size in fig. 33, top view; fig. 34, side view. Through the rivet hole, B, it is riveted to the bottom of the magazine floor. Its lip, A, projects to the right beyond the floor, which it thereby serves to extend when the cartridges are introduced.

The *side plate* is represented, full size, in fig. 35, interior side view; fig. 36, top view. Closing the left side of the magazine its curved surface causes the cartridges

under the influence of the carrier and follower to rise up to the maga-

zine channel. The ramp, A, with the corresponding ramp in the receiver, directs the point of the bullet into the chamber. Other parts are the lip, B, and the screw hole, C. The screw, fig. 37, full size, with the lip on the side plate, secures it to the receiver.

The *gate* is represented, full size, in fig. 38, front view, and fig. 39, interior view. The parts are the thumb piece, A, by which the gate is opened and closed; the top, B; the back, C; the face, D, which rests against the right wall of the receiver when the gate is closed; the

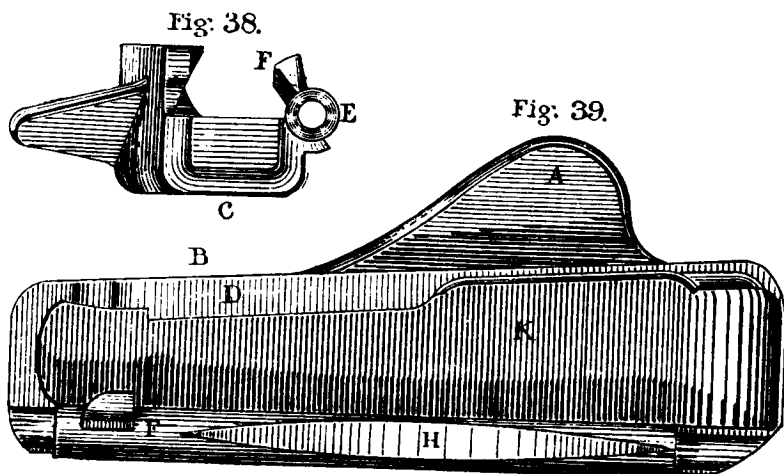

hinge, E, through which the hinge bar passes; the lug, F, which retracts the carrier within the well of the gate when opened; the spring surface, H, the bearing for the magazine spring; and the well, K, for the reception of the carrier and follower.

The *hinge bar* is shown, full size, in fig. 40. Passing through the hinge in the gate and the ears on the right of the magazine it forms the hinge about which the gate turns.

Fig. 40.

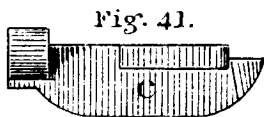

Fig. 41.



Fig. 42.

The *hinge bar head* is shown, full size, in figs. 41 and 42. The parts are the thumb piece, A, for turning and removing the hinge bar; the hinge bar hole, B, into which the hinge bar is riveted; and the spring, C, which secures the bar in its position.

The *magazine spring*, represented, full size, in figs. 43 and 44, is placed

Fig. 43.



Fig. 44.

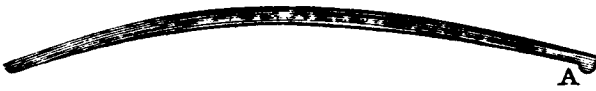

in the groove in the right side of the magazine floor. The lip, A, bears upon the heel of the carrier arbor. The spring also serves to retain the

gate either open or shut.

The *carrier* is represented, full size, in fig. 45, top view; fig. 46, side view. The parts are the point, A, which bears against the cartridges, and under the influence of the magazine spring moves them

Fig. 45.

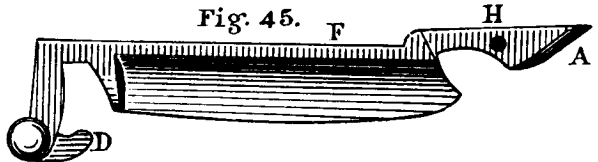

through the magazine; the face, B, whose curved surface guides the cartridges into the magazine as they are introduced; the arbor, C; the heel, D; the cam, E, upon which the gate lug bears to retract the carrier within the gate; the back, F; and the follower pin hole, H.

Fig. 46.

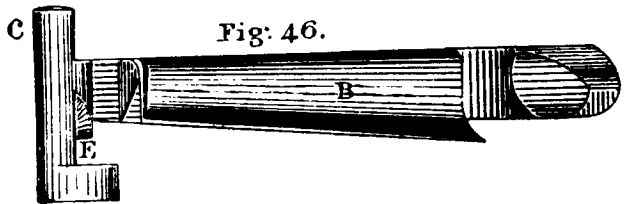

The *follower* is shown, full size, in fig. 47, side view; fig. 48, top view. The parts are the face, A, which rests upon the last cartridge when the magazine is full; the top, B, which finally raises this last cartridge up to the magazine channel; the back, C; and the pin holes, D.

Fig. 47.

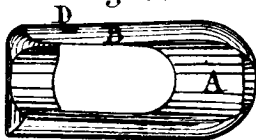

Fig. 48.

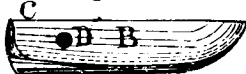

Fig. 49.



The *follower pin*, shown full size in fig. 49, connects the follower and carrier. Being riveted to the follower and passing loosely through the carrier it acts as an arbor, permitting slight rotation of the former, limited by the shape of the carrier.

The *cut-off* is represented, full size, in fig. 50, side view; fig. 51, end view. Its parts are the thumb piece, A; spring slot, B; spindle body, C; and spindle point, D. When the thumb piece is turned down the spindle point lies entirely within the groove in the left wall of the

receiver. When the thumb piece is turned up the spindle point rotates into the magazine channel, pressing the cartridges down in the magazine, holding them below the action of the bolt, and placing the arm ready for "single loader fire."

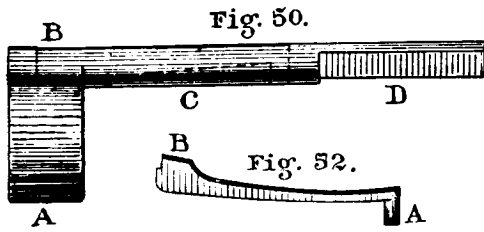

The *cut-off spring* is shown, full size, in fig. 52. The parts are the stud, A, which enters the hole at the end of the slot in the spindle body; and the lug, B, which, bearing upon the bottom of the groove in the receiver, retains the cut-off for either single or magazine fire, as it may be adjusted. It also secures the cut-off in its groove.

The *trigger* is shown, full size, in fig. 53, side view; fig. 54, front view. The parts are the finger piece, A; the sear recess, B; the half pull bearings, C; the blade, D; and the pin holes, E. Under the pressure of the sear spring the bearings, C, on the trigger are in contact with the bottom of the receiver tang, and so remain during the initial pressure on the finger piece; as this pressure continues the bearing is transferred to the blade, which retains it until the trigger is released.

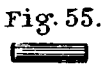
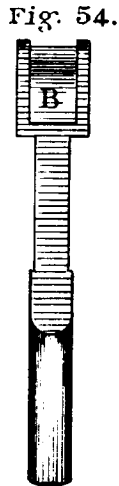
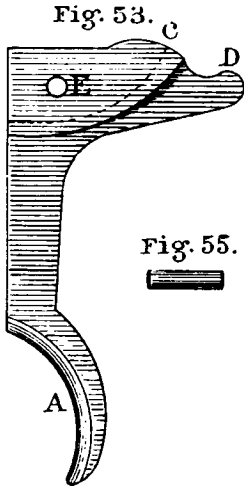

The *trigger pin*, represented full size in fig. 55, is securely attached to the sides of the sear recess in the trigger; passing through the sear it acts as a hinge for the latter in the joint movement of sear and trigger.

The *sear* is represented, full size, in fig. 56, front view; fig. 57, side view. The parts are the nose, A; the body, B; the hinge, C; the sear spring hole, D; and the trigger pin hole, E. The hole in the hinge performs no part in the action of the mechanism, being added merely to facilitate

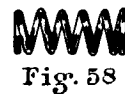
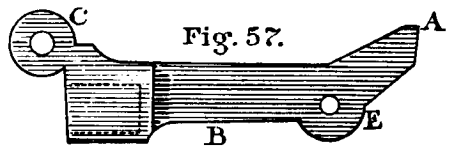



late manufacture. Under the influence of the sear spring the nose of the sear projects into the cut in the tang of the receiver.

The *sear spring* is shown, full size, in fig. 58. Contained in the sear spring hole in the sear, its end bears against the back of the rear wall of the magazine. It serves to induce a rotation of the sear, causing the sear nose to rise into the cut in the tang of the receiver.

Fig. 59 represents the front and fig. 60 the side view, full size, of

Fig. 59.

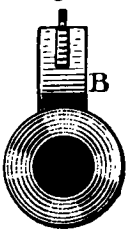
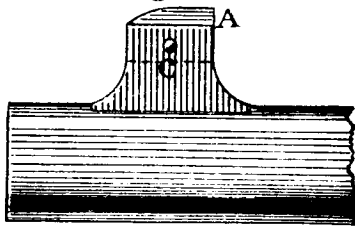

Fig. 60.



the *front sight*, A, and the *front-sight stud*, B, the latter of which is brazed on the barrel. The sight, A, is removable, so that it can be replaced in case of wear. It is secured to the stud by a pin, C.

The *rear sight* complete is shown in fig. 61, face; fig. 62, side view, full size, leaf raised. The principal parts are A, base; B, leaf; C, slide. The sight is graduated for ranges from 300 to 600 yards on the base, and on the leaf for ranges from 700 to 1,900 yards. Steps on the base and notches on the leaf restrict the sight adjustment to the intervals of 100 yards between these limits.

Fig. 61.

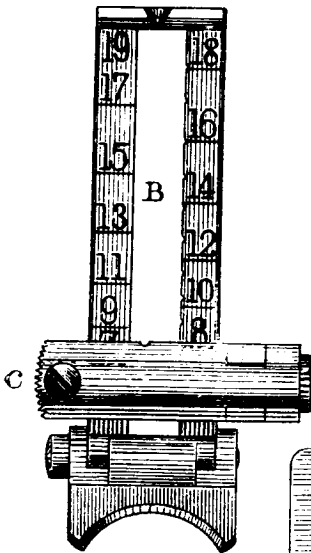
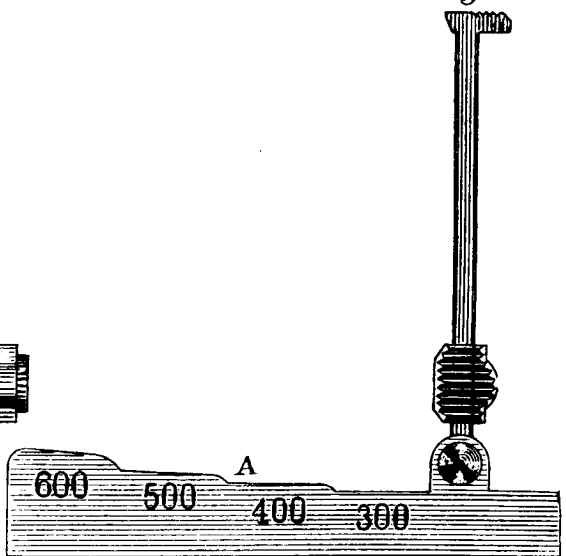

Fig. 62.



The *base* is shown, full size, in fig. 63, top view; fig. 64, left side. The sides, A, of the base are raised by steps giving the elevations 300 (the lowest sight adjustment for the rifle), 400, 500, and 600 yards. The other parts are the screw holes, B; the hinge ears, C; and the undercut slot, on the inner part of the sides, near the front end, for the base spring.

Fig. 63.

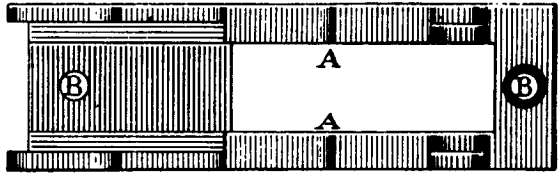

Fig. 64.

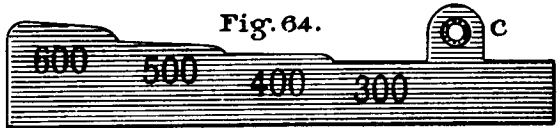

Fig. 65.

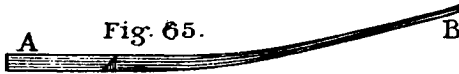

Fig. 66.



Fig. 67. A



Fig. 67. B

Fig. 68.

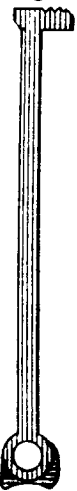

Fig. 69.



The *base spring* is represented, full size, in fig. 65, side view; fig. 66, top view. The heel, A, engages in the slot in the sides of the base; the point, B, bears upon the lower end of the leaf; C is the screw hole.

Fig. 67 represents, full size, the *base screws*—A the front, B the rear; they secure the sight base to the barrel.

The *rear-sight leaf* is shown, full size, in fig. 68, side view; fig. 69, face view; fig. 70, rear or lower end view. The graduations, from 700 to 1,900 yards, are given alternately on the two arms of the leaf. On the inner side of the right arm are notches in which the catch of the slide engages for ranges differing by each 100 yards between these limits. On the cross arm at the upper end is the sight notch, used when the leaf is down on the base for the ranges from 300

Fig. 71.



Fig. 70.



yards from 300

to 600 yards. Placed to the left of the axis of the barrel it corrects for the drift at a single distance; 500 yards has been selected; for 300 and 400 yards the drift correction is then slightly in excess of the true amount; for 600 yards it is slightly too small. The hinge arm at the bottom or rear of the leaf is so shaped that the base spring will retain the leaf turned down, either forward or back, or raised to the vertical position.

Fig. 71 represents, full size, the *joint pin*. Passing through the left hinge ear on the base, through the hinge hole on the leaf, and screwed into the right hinge ear on the base it serves as the hinge about which the leaf moves.

The *rear-sight slide block* is shown, full size, in fig. 72, face view; fig. 73, lower side; fig. 74, right end. The parts are the slide-cap screw hole, A; the cuts, B, for the arms of the leaf; the grooves, C and D, for the hook and the heel of the catch; the hole, E, for the catch spring; the shoulders, F, for the slide cap; the notch, H, which, when the slide is assembled, is in front of the sighting notch;



and the knurling, K, designed to afford a firm grasp for the thumb when moving the slide.

The *rear-sight slide cap* is represented, full size, in fig. 75, face view; fig. 76, inner side; fig. 77, right end. The parts are the screw hole, A; the grooves, C and D, for the spindle and heel of the catch; the shoulders, F, which engage over the corresponding shoulders on the slide block; the knurling, K, corresponding to the knurling on the slide block; and the sighting notch, N, which is used when the leaf is raised for ranges from 700 to 1,900 yards.

Placed to the left of the axis of the bore it corrects for the drift at 1,000 yards; for distances less than 1,000 yards it gives a correction slightly in excess of the true; for distances over 1,000 yards a correction less than the true amount.

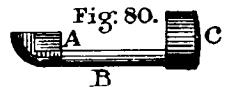
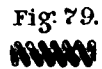
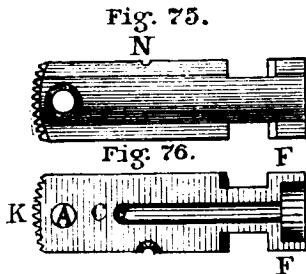

Fig. 78 represents the *slide cap screw*; fig. 79 the *slide catch spring*, and fig. 80 the *rear-sight slide catch*; all full size. The parts of the latter are the hook, A, which engages in the notches in the right arm of the sight leaf, the spindle, B; and the heel, C. The spring bears between the bottom of the hole in the slide block and the face, C, of

the heel of the catch. Pressing the heel to the left frees the hook from the notches of the leaf and permits movement of the slide. The block, cap, screw, spring, and catch constitute, when assembled, the rear-sight slide (see C, figs. 61 and 62).

The *stock* is represented, one-eighth size, in fig. 81, top view; fig. 82, right side. The parts are A, butt and hole for the small butt plate

screw; B, comb; C, small of the stock; D, mortise for receiver tang and hole for rear guard screw; E, mortise for sear and cut for trigger; F, cut for handle recess on receiver; G, hole for front guard screw; H, head, the shoulder for receiver and magazine; K, bed for magazine; M, groove for carrier lug; N, cut for hinge bar head; P, bed for front of receiver and hole for ramrod stop; Q, beds for hand guard springs; R, grooves for hand; S, shoulders for bands; T, hole for lower band pin; T', hole for upper band screw; W, bed for barrel.

The stock is made of black walnut.

The *hand guard* is represented, one-fourth size, in fig.

83, side view; fig. 84, inner view. It extends over the barrel from the receiver to the lower band, and

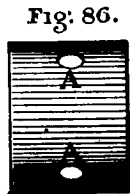
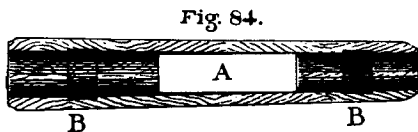
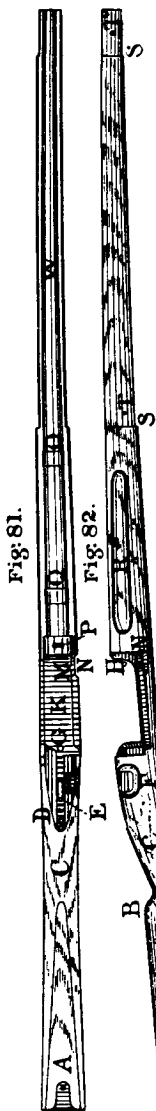

is intended to shield the hand from a barrel heated by rapid firing. The parts are A, mortise for rear sight; B, cuts for springs which attach the guard to the barrel; C, holes for the rivets which secure the springs to the hand guard.

The *front hand guard spring* is shown, full size, in fig. 85, side view; fig. 86, top view. A A are the rivet holes. The rear hand guard spring is similar to but slightly larger than the front, on account of the slope of the barrel. Each spring is secured to the guard by two rivets.

Fig. 87 shows, full size, one of the *hand guard rivets, front*. The rear rivets differ from the front only in being slightly longer.

Fig. 88 represents the ramrod, full size. The head, A, is slotted for the cleaning cloth; the lower end is threaded and screws into the ramrod stop.

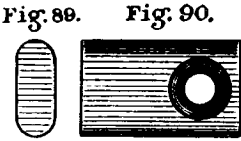

The ramrod stop is shown, full size, in fig. 89, end view; fig. 90, side view. It is tapped for the thread on the ramrod. The stop is inserted in the hole made in the stock for that purpose, just in front of the bed for the magazine.

The trigger guard is represented, half size, in fig. 91, side view; fig. 92, top view. The parts are the plate, A; the bow, B; and the holes, C, for the guard screws.

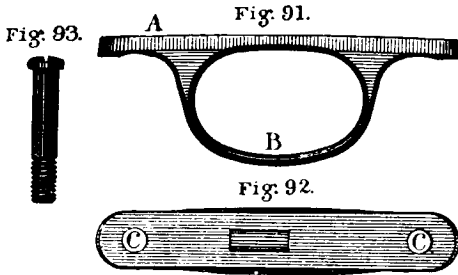

The rear guard screw is shown in fig. 93; the front guard screw in fig. 94; both half size. They pass through holes

in the stock and screw; the rear into the hole at the rear of the tang; the front into the hole at the rear of the magazine floor.

The butt plate is shown, one-half size, in fig. 95, side view; fig. 96, bottom view; fig. 97, rear view. The parts are A, body; B, tang; C, heel; D, screw holes; D', toe.

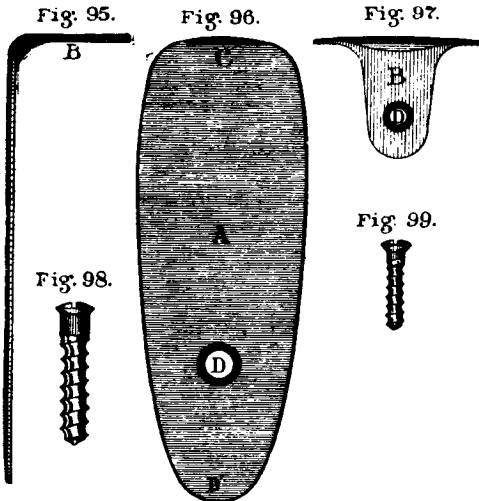

The butt plate screws are shown, one-half size, in figs. 98 and 99. The smaller screw passes through the tang; the larger through the body of the butt.

The butt swivel plate is shown, half size, in fig. 100, side view; fig. 101, bottom face. The holes in the plate are A, for the swivel screws; B, the swivel; and C, the swivel pin.



FIG. 88.

Fig. 102 shows the *butt swivel*; fig. 103, the *butt swivel pin*; fig. 104, the *butt swivel plate screws*, all half size. The pin retains the swivel in the plate; the screws, two in number, secure the plate to the stock.

The *upper band* is shown, half size, in fig. 105, front view; fig. 106, side view. The parts are A, bayonet stud; B, ramrod hole; C, stacking swivel ears; D, swivel screw hole; E, band screw hole.

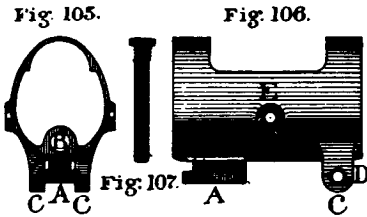

The screw passing directly through the tip of the stock retains the band in place; removing the screw, the band can be slipped off the stock on to the barrel, but can not be entirely removed until the front sight is taken out of the stud.

Fig. 107 shows the *upper band screw*, half size; fig. 108 shows the *stacking swivel*; both half size.

The lug, A, entering between the ears (C, fig. 106) on the upper band is retained in place by the screw, about which it has, however, free motion.

The *lower band* is represented, half size, in fig. 110, top view; fig. 111, side view. The parts are A, body; B, creases; C, shoulders; D, swivel ears; E, swivel screw holes.

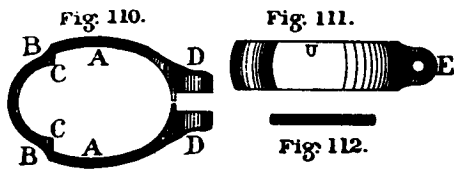

It rests upon a shoulder in the stock, and is prevented from slipping forward by the band pin.

Fig. 112 shows the *lower band pin*, half size. It passes through the stock, projecting slightly at either side, just above the lower band.

The *knife bayonet* is shown complete in fig. 115, right side; fig. 116, back; both quarter size. The parts are the blade, A, and hilt, B; the latter made up of the guard, C; gripe, D; pommel, E; and catch, F, with its bolt, nut, and spring.

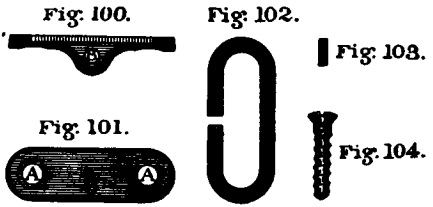
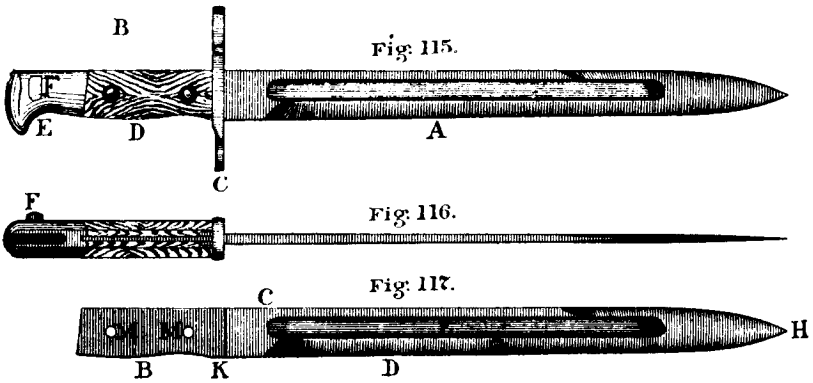

Fig. 117 gives a side view of the *blade*, quarter size. The parts are the body (or blade proper), and the tang, B; on the body the back, C;



edge, D; grooves, E, alike on either side of the blade body; bevel, G; and point, H; on the tang the shoulder, K, for the guard; and the rivet holes, M.

The *bayonet guard* is represented, half size, in fig. 118, rear view; fig. 119, side view. The parts are the barrel ring, A, which engages over the muzzle of the barrel when the bayonet is fixed; and the mortise, B, and flanges, C, for the blade tang. The guard is brazed to the blade where the body merges into the tang.

Fig. 118.

Fig. 119.

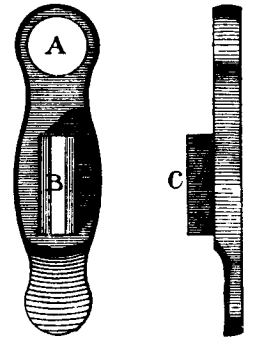

The *pommel* is shown, half size, in fig. 120, back; fig. 121, side view.

Fig. 120.

Fig. 121.

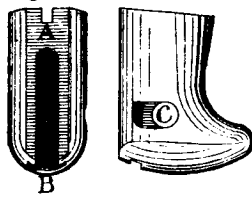

The parts are the mortise, A, for tang, when the tang and pommel are brazed together; the undercut groove, B, for the bayonet stud on the upper band; and the hole, C, for the catch and its spring.

Fig. 122 shows the *bayonet catch nut*; fig. 123, the catch spring; both full size. The nut, besides retaining the catch in the pommel, serves also as a thumb piece for its manipulation. The spring bears between the nut and a shoulder in the hole in the pommel.

Fig. 122.

Fig. 123.

Fig. 124.



Fig. 124 represents the *bayonet catch*, full size. The parts are the thread, A, for the nut on thumb piece; the spindle, B; the cam, C; and the stop, D. When assembled, the edge of the catch stop, under the action of the catch spring, projects into the undercut groove in the back of the pommel. In the act of fixing the bayonet, the bayonet stud, after entering this groove, comes into contact with the cam on the catch, forcing the catch until the stud passes, when the

catch spring causes the face of the stop to return into the pommel groove, but below the bayonet stud, which is thus held firmly in position in the pommel.

The *gripe* consists of a wooden body, two similar pieces shown, half size, in fig. 125. They cover the tang between the guard and the face of the pommel, being held in place by two rivets, fig. 126, with washers, fig. 127, at either end.

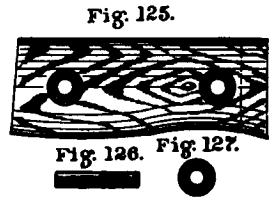

CARBINE.

The breech and magazine mechanism of the carbine, the caliber of the arm, and the cartridge used are the same as for the rifle. All the other parts are the same as for the rifle, except as below enumerated.

The barrel is 22 inches long, or 8 inches shorter than the rifle barrel. Its exterior dimensions are the same as those of the lower 22 inches of the rifle barrel.

The form of the rear sight is the same as for the rifle; but the length of the barrel giving a lower initial velocity to the bullet, and the distance between the front and rear sights being 8 inches less than in the rifle, the graduation for range is different. The carbine rear sight is distinguished by the letter "C" stamped on the left side of the base and on the top of the leaf. The stock is 7.85 inches shorter than the rifle stock. The carbine upper band being narrower than for the rifle, its shoulder is nearer the tip than on the rifle stock. The shoulder for the rear band is immediately in front of the rear sight. There is but one bed, the rear, for hand guard spring. The grooves for the hand are shorter than on the rifle. The bed for butt swivel plate and holes for its screws are omitted. A bed is made on the left side of the small of the stock for the swivel plate, and holes for the swivel plate screws.

The carbine upper band differs from the one for the rifle in having no bayonet stud nor ears for stacking swivel. It is, therefore, made shorter. It is shown, half size, in fig. 137, front view; fig. 138, side view. The ramrod hole is shown at A; the band screw hole at B. The band screw is the same as on the rifle.

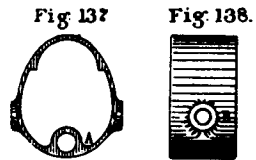

The carbine lower band is represented, half size, in fig. 139, front view; fig. 140, side view. The parts are A, body; B, sight protecting shoulder; C, sighting notch; D, bed for barrel; E, hand guard notches; F, screw holes; H, ears. Besides securing the barrel to the stock, the band serves to protect the front of the rear sight when, the leaf having been turned down on the base, the carbine is inserted in the boot.

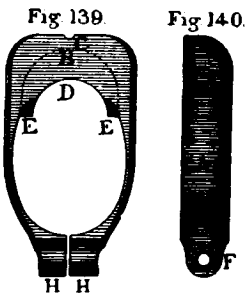

The lower band swivel of the rifle is omitted on the carbine.



The butt swivel, its plate and screws, of the rifle, are omitted on the carbine. The carbine swivel is composed of the bar, ring, and plate. The carbine swivel bar is represented, half size, in fig. 141, side view. The parts are the bar, A; the shoulder, B; and ends, C. The ends pass through the holes in the swivel plate and are riveted to its under side.

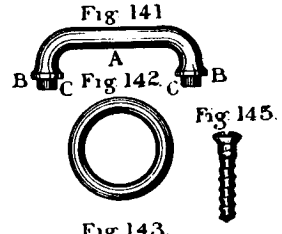

The carbine swivel ring is shown, half size, in fig. 142. It is placed on the bar before the latter is riveted to the plate.

The carbine swivel plate is shown, half size, in fig. 143, side view; fig. 144, top view. The parts are A, body; B, swivel bar holes; C, screw holes.

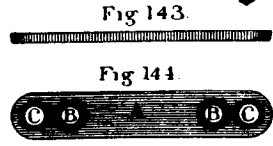

One of the two carbine swivel screws is shown, half size, in fig. 145.

The carbine hand guard is represented, one-fourth size, in fig. 146, side view; fig. 147, inner view. It differs from the one for the rifle in that the part in front of the rear sight is cut off, the two arms on either side of the sight entering into the notches on the lower band. There is but one hand guard spring, the rear spring of the rifle hand guard. The carbine ram-rod differs from that for the rifle merely in

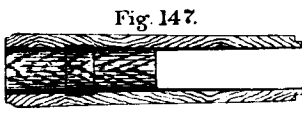

being 8 inches shorter.

THE ASSEMBLED PARTS AND THEIR OPERATION.

The bolt, assembled, is shown, three-fourths size, in fig. 128, the parts being placed as they appear when the bolt is drawn fully back in the operation of extracting the empty cartridge case. In this position the main spring is half compressed, and so retained by the nose of the cocking piece resting in the small notch at the end of the bolt.

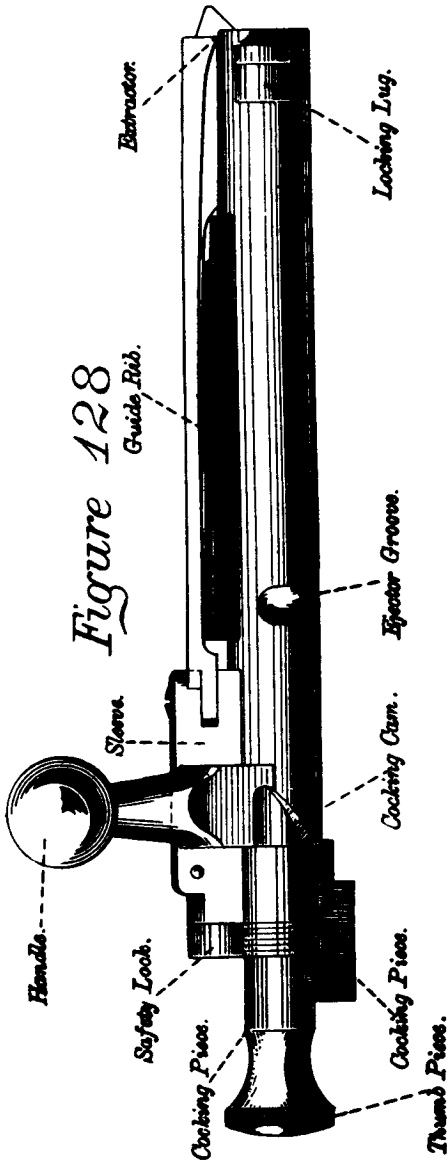
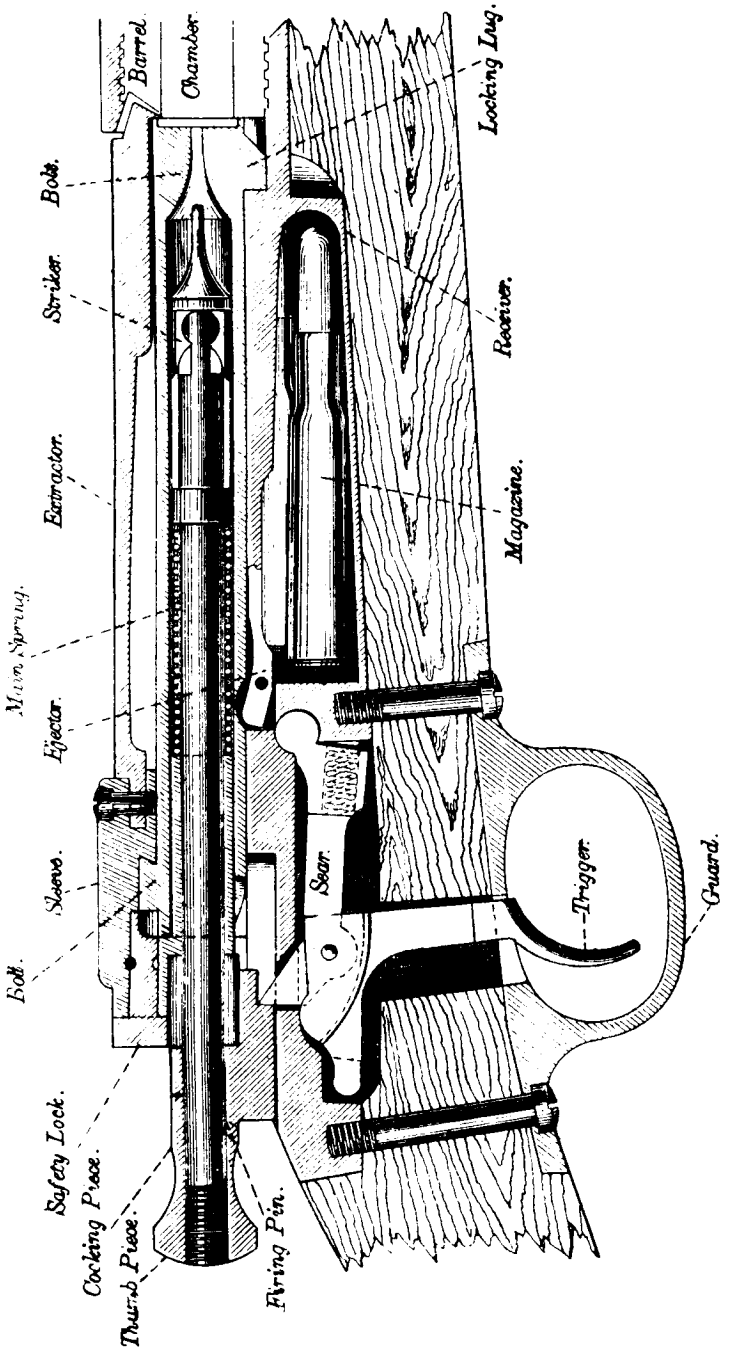

Fig. 129 represents a section, three-fourths size, of the breech mechanism, trigger and sear, magazine, etc., by a vertical plane through the axis of the bore, showing the names of the several parts and their relative position when the bolt is closed, the gun ready for firing. The main spring is fully compressed, bearing at the rear against the forward end of the sleeve spindle and at the front against the rear of the striker, the firing pin and striker fully drawn back, and so retained by the nose of the sear engaging on the shoulder of the cocking piece; the locking lug of the bolt has fully entered the locking recess in the floor of the receiver. If now the trigger be pulled it will draw downward the nose of the sear, freeing the cocking piece, and with it the firing pin and striker, thus releasing the forward bearing of the main spring (the rear bearing, the sleeve spindle remains secured), and therefore causing the striker to move rapidly forward and impinge upon the primer, discharging the piece.

The shock of discharge is sustained by the bolt's locking lug. This lug is fully equal to the strain brought upon it; but in case of its failure the shoulder of the guide

rib and the base of the handle, in their respective bearings in the receiver, will successively perform this function of the lug and permit the continued use of the piece.

Figure 129



The gun having been discharged, to remove the empty shell, reload, and fire, the mechanism operates as follows:

Beginning to turn the bolt handle upward and to the left, the nose of the cocking piece, which was buried in the depth of the cocking cam at the rear of the bolt, and which, lying in the channel in the receiver tang, can not itself turn, is forced back as the bolt turns along the cam, thus withdrawing the striker from the primer, and, as the sleeve spindle, the rear bearing of the main spring, has not moved, partly compressing the main spring. The initial movement is made easy by the fact that the vertical plane containing the locking shoulder of the receiver and the rear of the bolt lug is not quite at right angles to the axis of the bolt. These two surfaces, brought into strong contact by the discharge, therefore separate as soon as rotation of the bolt commences.

Continuing the motion of the handle, the retraction of the cocking piece and striker, and consequent compression of the main spring, continue until the handle comes into bearing against the rear of the curved shoulder on the right wall of the receiver, when the entire bolt also moves slightly to the rear, commencing the extraction of the empty shell.

At the final stage of the rotation the shoulder on the cocking piece passes the point of the sear, followed immediately by the nose of the cocking piece engaging in the small notch in the rear of the bolt body. The parts of the bolt will then be in the positions shown in fig. 128.

The bolt can then be drawn back, the locking lug moving along the guide rail of the right wall, and the guide rib along the left wall, of the receiver, and the extractor, and below it also the guide rib, passing through the channel formed by the converging of these walls at the rear of the receiver.

The hook of the extractor brings with it the empty cartridge case until near the end of the bolt's movement to the rear, the ejector is operated, striking the shell near its center and causing it, in connection with the hold of the hook of the extractor, to fly up out of the receiver and slightly to the right.

Immediately thereafter the bolt's motion to the rear is stopped by the locking lug striking the locking shoulder on the right wall of the receiver.

If the magazine is empty, or, if charged, has the cut-off adjusted for single-loader fire, a cartridge may now be dropped into the receiver in front of the bolt or may be partly inserted in the chamber, though the latter action is not necessary as the bolt in its subsequent forward motion will carry the cartridge to the chamber. Or, if the magazine is charged and thrown into action by the cut-off, its upper cartridge, as the bolt is drawn fully back, rises, bringing the upper right-hand part of the head in front of the lower left-hand portion of the front of the bolt. The forward motion of the bolt then pushes this cartridge through the channel from magazine to receiver and into the chamber.

As the bolt is returned, its action, until the base of the handle strikes against the rear of the shoulder on right receiver wall, is merely to advance a cartridge, whether in single or magazine fire, to the chamber, nearly completing insertion. At the same time the cocking shoulder also impinges upon the nose of the sear.

Endeavoring to further return the bolt, the handle bearing against the rear or extracting shoulder of the right receiver wall converts the motion into a rotation to the right, combined, in consequence of the bearing of the rear of the guide rib upon the front or locking shoulder of this wall, with a slight forward movement of the bolt. This forward movement is continued by the bearing of the locking lug on the cam of the locking recess in the receiver, completing the full insertion of the cartridge.

When the shoulder of the cocking piece impinges upon the nose of the sear, the forward motion of the cocking piece, and therefore of firing pin and striker, is stopped. The subsequent rotation and slight advance of the bolt carrying with it the sleeve and advancing the rear bearing of the main spring therefore gives a further and final compression to this spring.

The hook of the extractor engages over the cartridge head during the last stages of the bolt's forward movement.

Upon completion of these operations the positions of the parts will be as given in fig. 129.

It will be observed that the first effect of moving the handle is to withdraw the point of the striker from the primer and to move the locking lug from its bearing upon the face of the locking shoulder, and not until the compression of the main spring is well under way, the upward motion of the handle more than half completed, and the bolt rotating freely, is there any movement of the bolt to the rear or any pull of the extractor upon the empty shell. To start the shell the camming effect of the base of the handle moving along the curved right wall, the extracting shoulder of the receiver, then greatly supplements the force applied by the soldier, and not until the shell is free is there any direct rear pull.

In a similar way the cam on the rear of the bolt body effects, during the rotation of the handle, the first and then the continued compression of the main spring; and as the final compression is caused by the bolt's slight advance during its last rotation, the cams, instead of a direct push upon the bolt handle, cock the piece, thus accomplishing the operation with a minimum exertion and insuring ease and smoothness to the action.

If the trigger is pulled before the bolt is entirely closed, the nose of the cocking piece acting on the cocking cam at the rear of the bolt will cause it to rotate, and not until it is securely locked can the striker reach and explode the primer.

In case of a missfire the arm can be recocked by grasping and drawing back the cocking piece, or by turning up and then immediately down the bolt handle without drawing the bolt to the rear.

Fig. 130 represents a cross section, through toe of ejector, of the receiver and the magazine, the latter fully charged, but cut off, the bolt closed; fig. 131, a cross section when the magazine has been turned on and all but the last cartridge fired, bolt drawn fully back; both figures three-fourths size.

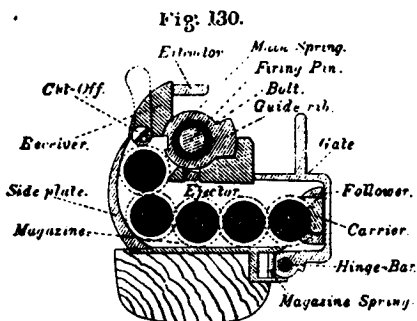
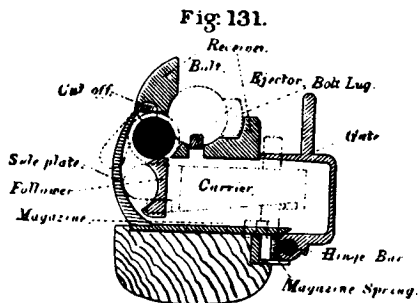

With the magazine cut off, the cut-off spindle bears down upon the head of the upper cartridge, pressing it back into the magazine and below the action of the bolt. The

magazine mechanism, therefore, remains inert, and the arm operates as a single loader in the manner previously described.

Turning down the cut-off thumb piece rotates the spindle into its channel in the receiver, permitting the cartridges in the magazine to rise until the head of the upper one projects sufficiently into the receiver to be struck by the head of the bolt in its forward movement. By advancing the bolt this cartridge is now pushed forward, the ramp on the side plate and the corresponding ramp on receiver guiding the point of the bullet into the chamber. The body of the cartridge passes quickly into the receiver when it reaches the enlarged portion of the magazine channel. During this passage the cartridge is held up into the magazine channel by the pressure of those below as they are urged on by the point of the carrier.

The carrier bearing against the last cartridge pushes the preceding ones in succession against the side plate and then, owing to the curved surface of the latter, up to the magazine channel. When but one cartridge remains in the magazine, the carrier pushing it against the side plate causes it to ride up on to the top of the follower, which then holds it in the magazine channel. The point of the carrier then rests against the inner surface of the side plate.

The magazine having been emptied can be filled, or, if one or more cartridges have been fired from it, can be replenished, by first opening the gate. The lug on the latter acting on the heel of the carrier retracts the carrier and follower within the recess of the gate, leaving an opening through which cartridges are introduced. The gate is held open by the bearing of the magazine spring upon its lower surface. Pushing the gate to the left to close it, the bearing of the magazine spring changes, so that it aids the movement of closing and holds it shut.

The magazine can be charged, whether the bolt is forward or drawn back, and whether the cut-off is arranged for single loader or magazine fire.

#### PRECAUTIONS.

If it is desired to carry the arm with a cartridge in the chamber, the mechanism should always be secured by means of the safety lock.

No attempt should be made to operate the safety lock except when the arm is cocked.

As in all magazine arms, if a cartridge is pushed from the magazine *partly* into the chamber, and then the bolt fully drawn back, the first cartridge will remain in the receiver and a second will rise from the magazine in front of the bolt. If the bolt is then again pushed forward the effort to move the second cartridge to the chamber will cause a jam. To avoid this, fully close the bolt in the first instance, insuring the grasp of the extractor upon the first cartridge and its ejection when the bolt is withdrawn.

After closing the bolt upon an empty chamber the trigger should always be pulled, releasing the main spring, which should never be retained compressed except when the arm is loaded.

#### DISMOUNTING AND ASSEMBLING BY SOLDIER.

The breech and magazine mechanism, except the ejector and the side plate, can be dismounted without removing the barrel from the stock. This latter should never be done by the soldier, but only by some selected and instructed man when necessary for further cleaning or for repairs.

#### TO DISMOUNT BOLT.

(NOTE.—In the following figures the parts are depicted from the point of view of the operator holding them.)

(1) Place the piece across hollow of left arm and with right hand draw bolt back to full extent.

Fig. 132.

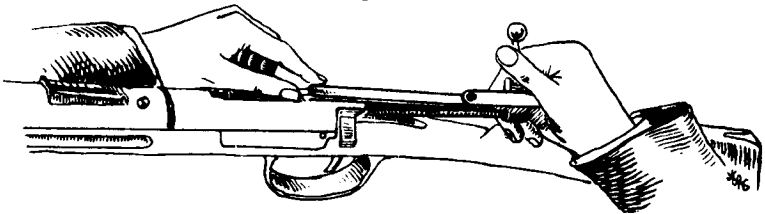

(2) Lift hook of extractor with left thumb and at the same time turn bolt handle to left with right hand (fig. 132). The bolt can then be drawn from receiver.

(3) Take bolt, upside down, in left hand, back of the hand down, second, third, and fourth fingers grasping handle, first finger under and partly around bolt, thumb resting on bolt. Grasp checked end of cocking piece with right hand (fig. 133).

Fig. 133.

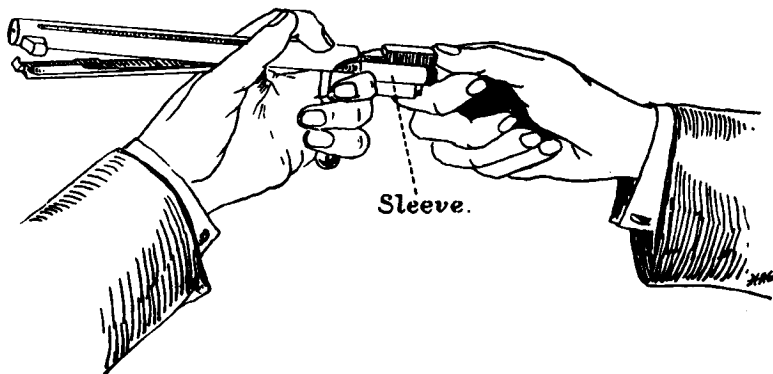

(4) Slightly draw back cocking piece and turn it to the left until firing pin can be drawn from the bolt.

(5) Take firing pin in left hand and bear down on point of striker with right thumb; remove main spring from pin, and pin from sleeve.

TO ASSEMBLE BOLT.

(1) Observe that the thumb piece of safety lock is turned to the left. Reverse the order of the steps of the last (the fifth) operation in dismounting.

Fig. 134.

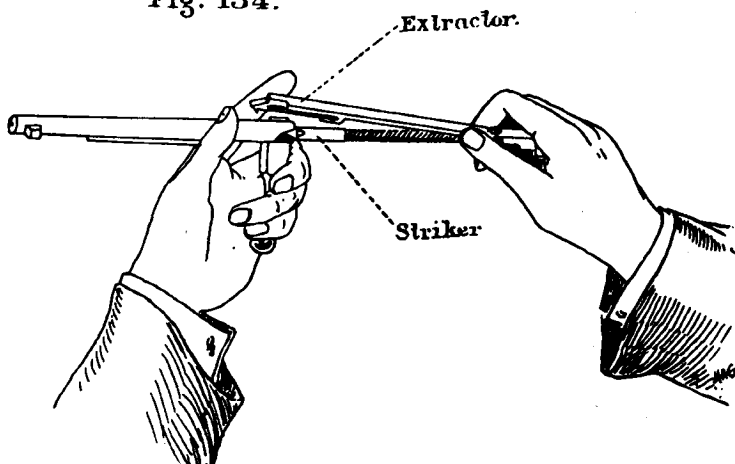

(2) Grasp bolt in left hand, as in third operation in dismounting, and the firing pin in right hand, extractor uppermost (fig. 134). Push firing pin into bolt.



(3) Grasp handle of bolt in left hand, bolt directed downward, and with both thumbs in rear of safety lock (fig. 135), push forward strongly and, continuing pressure, turn thumbs to right.

Fig. 135.

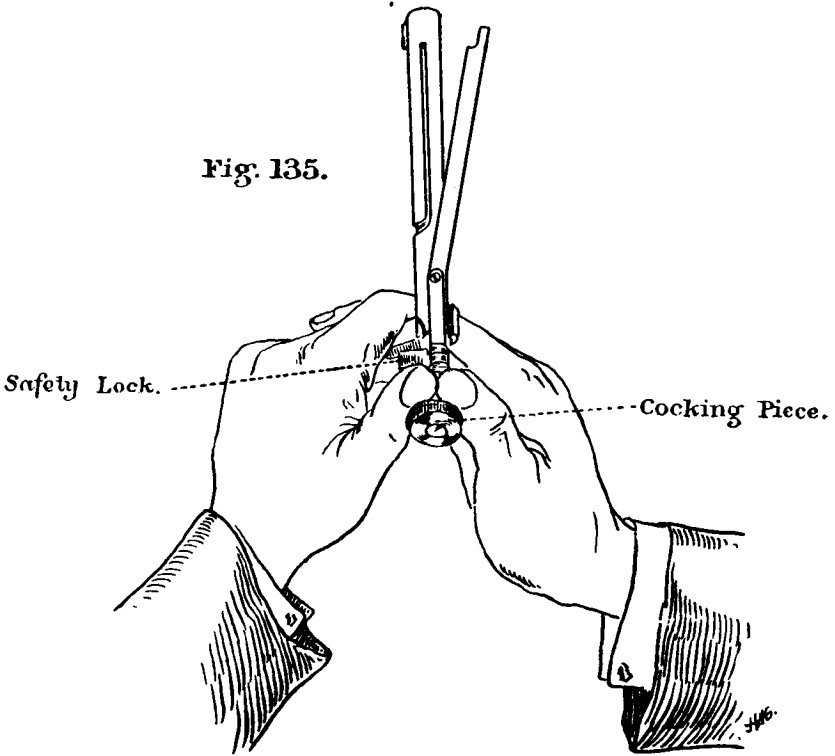

(4) Grasp bolt and cocking piece as in the third operation for dismounting. Draw back and turn cocking piece to right until its nose engages in the small notch on rear end of bolt (fig. 133).

(5) Take bolt in right hand and introduce it into receiver, keeping with the right thumb the extractor lifted (fig. 136). Turn bolt to right

Fig. 136.

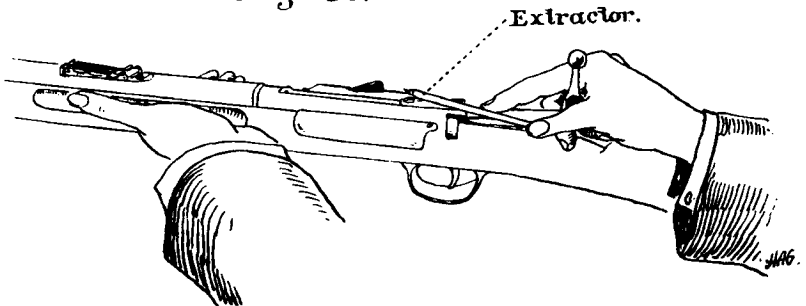

as soon as possible, and at the same time press strongly with first finger against right side of extractor.

## TO DISMOUNT MAGAZINE MECHANISM.

(1) The gate being closed, with point of screw driver inserted between stock and lug at front of hinge bar, or between stock and hinge bar head, turn the bar, and then, pressing against the lug, push the bar forward and free from the receiver.

(2) Turn the piece over to the right. The gate, magazine spring, and carrier, with follower, will fall from the magazine to the hand held to receive them.

## TO ASSEMBLE MAGAZINE MECHANISM.

(1) Hold the piece with right side uppermost. Insert spindle of carrier into hinge hole in receiver, having first placed end of thumb of left hand across magazine to prevent the turning down of carrier and follower.

(2) Place magazine spring in its channel, convex side up, rounded end to rear, other end resting upon lug of carrier spindle.

(3) Place gate over carrier, lug entering between carrier and magazine spring. Remove left thumb and at the same time press gate down firmly on carrier with right hand.

(4) Insert hinge pin into front hinge hole. Press down strongly on rear of gate until hinge pin can be pushed through gate into rear hinge hole of receiver. After pin is fully home turn down lug.

## TO COMPLETE DISMOUNTING (NOT BY SOLDIER).

(1) Unscrew and remove ramrod.

(2) Remove upper band screw and slip band forward onto barrel. The band can not be taken from barrel unless the front sight is removed from its stud.

(3) Loosen lower band screw and slip band forward.

(4) Remove guard screws. The barrel can then be taken from the stock.

(5) Unscrew and remove side plate.

(6) Removing side plate discloses head of ejector pin. Insert point of screw driver under head of pin and withdraw it. Remove ejector.

(7) Press trigger forward until nose of sear is entirely free from cut in receiver tang; then bearing against right side of sear, push it clear of its seat.

(8) Turn down cut-off thumb piece; compress spring with screw driver and then draw cut-off to the rear.

(9) To remove hand guard it is necessary to either unscrew the rear sight base from the barrel, or else the leaf from the base. The barrel should never be unscrewed from the receiver.

## TO ASSEMBLE STOCK, BARREL, ETC.

Reverse and follow in inverse order the operations of dismounting.