

FIELD MANUAL  
NO 23-30

HEADQUARTERS  
DEPARTMENT OF THE ARMY  
Washington, DC, 27 December 1988

GRENADES AND PYROTECHNIC SIGNALS

CONTENTS

	Page
PREFACE .....	iii
INTRODUCTION .....	iv
CHAPTER 1. FUNDAMENTALS OF GRENADES	
1-1. Characteristics .....	1-1
1-2. Components .....	1-1
1-3. Mechanical Function .....	1-1
1-4. Fuzes .....	1-4
1-5. Fragmentation Hand Grenades .....	1-8
1-6. Chemical Smoke Hand Grenades .....	1-10
1-7. Riot Control Hand Grenades .....	1-14
1-8. Special-Purpose Hand Grenades .....	1-16
CHAPTER 2. UTILIZATION OF GRENADES	
2-1. Hand Grenade Carrying .....	2-1
2-2. Hand Grenade Gripping .....	2-3
2-3. Hand Grenade Throwing .....	2-5
CHAPTER 3. TACTICAL EMPLOYMENT OF GRENADES	
3-1. Application .....	3-1
3-2. Close Combat .....	3-1
3-3. Plans and Preparations for Combat .....	3-2
3-4. Employment Rules .....	3-3
3-5. Offensive Employment .....	3-3
3-6. Defensive Employment .....	3-8
3-7. Retrograde Operations Employment .....	3-13
3-8. Rear Area Operations Employment .....	3-14
3-9. Use Under Adverse Conditions .....	3-15

DISTRIBUTION RESTRICTION: Approved for public release; distribution is unlimited.

\*This manual supersedes FM 23-30, 16 December 1969.

	Page
CHAPTER 4. TRAINING PROGRAM	
4-1. Objectives .....	4-1
4-2. Training Courses .....	4-1
4-3. Collective Training .....	4-17
4-4. Sample Squad Situational Training Exercise .....	4-18
CHAPTER 5. GROUND PYROTECHNIC SIGNALS	
5-1. Characteristics .....	5-1
5-2. Capabilities and Uses .....	5-1
5-3. Hand-Held Signals .....	5-2
5-4. Surface Trip Flares .....	5-5
5-5. Simulators .....	5-6
5-6. Illumination Ground Signal Kits .....	5-7
APPENDIX A. THREAT HAND GRENADES .....	A-1
APPENDIX B. LIVE HAND GRENADE RANGE OPERATIONS CHECKLIST .....	B-1
APPENDIX C. HAND GRENADE SAFETY CONSIDERATIONS .....	C-1
APPENDIX D. OBSOLETE HAND GRENADES .....	D-1
APPENDIX E. RANGE CONSTRUCTION/MODIFICATION .....	E-1
APPENDIX F. NATO HAND GRENADES .....	F-1
APPENDIX G. HAND GRENADE QUALIFICATION SCORECARD .....	G-1
GLOSSARY .....	Glossary-1
REFERENCES .....	References-1
INDEX .....	Index-1

## PREFACE

The purpose of this manual is to orient soldiers to the functions and characteristics of hand grenades and ground pyrotechnic signals. It provides a reference for the identification and capabilities of various hand grenades and pyrotechnic signals. It also provides a guide for the proper handling and throwing of hand grenades, suggests methods and techniques for the tactical employment of hand grenades, and provides a guide for commanders conducting hand grenade training.

This manual provides information and guidance for the operation, use, and training of hand grenades. It is intended for two user groups: (1) training centers responsible for introducing and training soldiers to a basic knowledge level, and (2) field units -- officers and noncommissioned officers responsible for sustaining basic knowledge level skills and advancing soldier skills in the employment of hand grenades on the battlefield.

The development of new hand grenades and the improvement of existing hand grenades has resulted in many different grenade types within the US inventory. While only a limited number of grenade types are in production today for US Armed Forces, the majority of all hand grenades ever produced are either used by the armed forces of our allies or countries to which we occasionally provide military assistance. This manual will address hand grenades common to the US Army. Obsolete hand grenades, those less likely to be issued to US Army personnel, will be addressed in Appendix D.

The proponent of this publication is HQ TRADOC. Submit changes for improving this publication on DA Form 2028 (Recommended Changes to Publications and Blank Forms) and forward it to the Commandant, US Army Infantry School, ATTN: ATSH-IN-2B, Fort Benning, Georgia 31905-5598.

Unless otherwise stated, whenever the masculine gender is used, both men and women are included.

## INTRODUCTION

The rifle, bayonet, and hand grenade are the soldier's most lethal basic weapons. Historically, hand grenade training has received less emphasis than marksmanship and bayonet training. The hand grenade must receive greater emphasis in training programs and field training exercises. The proper use of hand grenades could determine the fate of individual soldiers or the success of the mission.

Leaders at all levels should study the employment of grenades in conjunction with the unit mission and implement a training program that supports that mission. Once soldiers can safely arm and throw live fragmentation grenades, units should integrate the use of grenades into collective tasks rather than training it as a separate event. Hand grenades must be integrated with the other available weapon systems to enhance the unit's combat power on the modern battlefield. Hand grenade training must be conducted in the same manner in which we plan to fight.

We cannot let the danger associated with hand grenades deter our training efforts. Proper control and safety procedures while using hand grenades will allow us to conduct this training in a safe manner. Train soldiers to standard, and safety will be inherent.

Hand grenades include more than the casualty-producing instruments of war. The hand grenades that support signal, screening, and crowd control efforts cannot be forgotten. The current inventory provides a specific hand grenade for most circumstances. Soldiers must be familiar with current grenades, their characteristics, and how each is best employed.

## CHAPTER 1

## FUNDAMENTALS OF GRENADES

There are several types of hand grenades. Each has different characteristics, and each provides the soldier with a variety of capabilities. Hand grenades give the soldier the ability to kill enemy soldiers, destroy enemy equipment, give signals, and control riots. Historically, the most important hand grenade is the fragmentation grenade. It is the soldier's personal indirect fire weapon system.

## 1-1. CHARACTERISTICS

Hand grenades share the following three common characteristics:

- o Their employment range is short.
- o Their effective casualty radius is small.
- o Their delay element permits safe throwing.

## 1-2. COMPONENTS

Hand grenades have the following main parts:

- o Body -- contains filler and, in certain grenades, also provides fragmentation.
- o Filler -- chemical or explosive substance in the grenade, which determines grenade use and characteristics.
- o Fuze assembly -- causes the grenade to function by igniting or detonating the filler.

## 1-3. MECHANICAL FUNCTION

The following is the proper procedure (and the results thereof) when preparing to throw a hand grenade.

- a. Insert the safety clip. All hand grenades do not have safety clips (NSN 1330-00-183-5996). However, a hand grenade safety clip is available through class V ammunition supply channels for some of these. It is adaptable to the M26- and M67-series, the MK2, and the M69 practice grenade. The safety clip prevents the safety lever from springing loose even if the safety pin assembly is accidentally removed. Adjustment instructions are illustrated

in Figure 1-1. Safety clip installation instructions are as follows:

(1) Hold fuzeed grenade in palm of hand with pull ring up (Figure 1-1).

(2) Insert small loop at open end of safety clip in slot of fuze body beneath the safety lever (Figure 1-1).

(3) Press clip across safety lever until closed end of clip touches safety lever and clip is snapped securely in place around the safety lever (Figure 1-1).

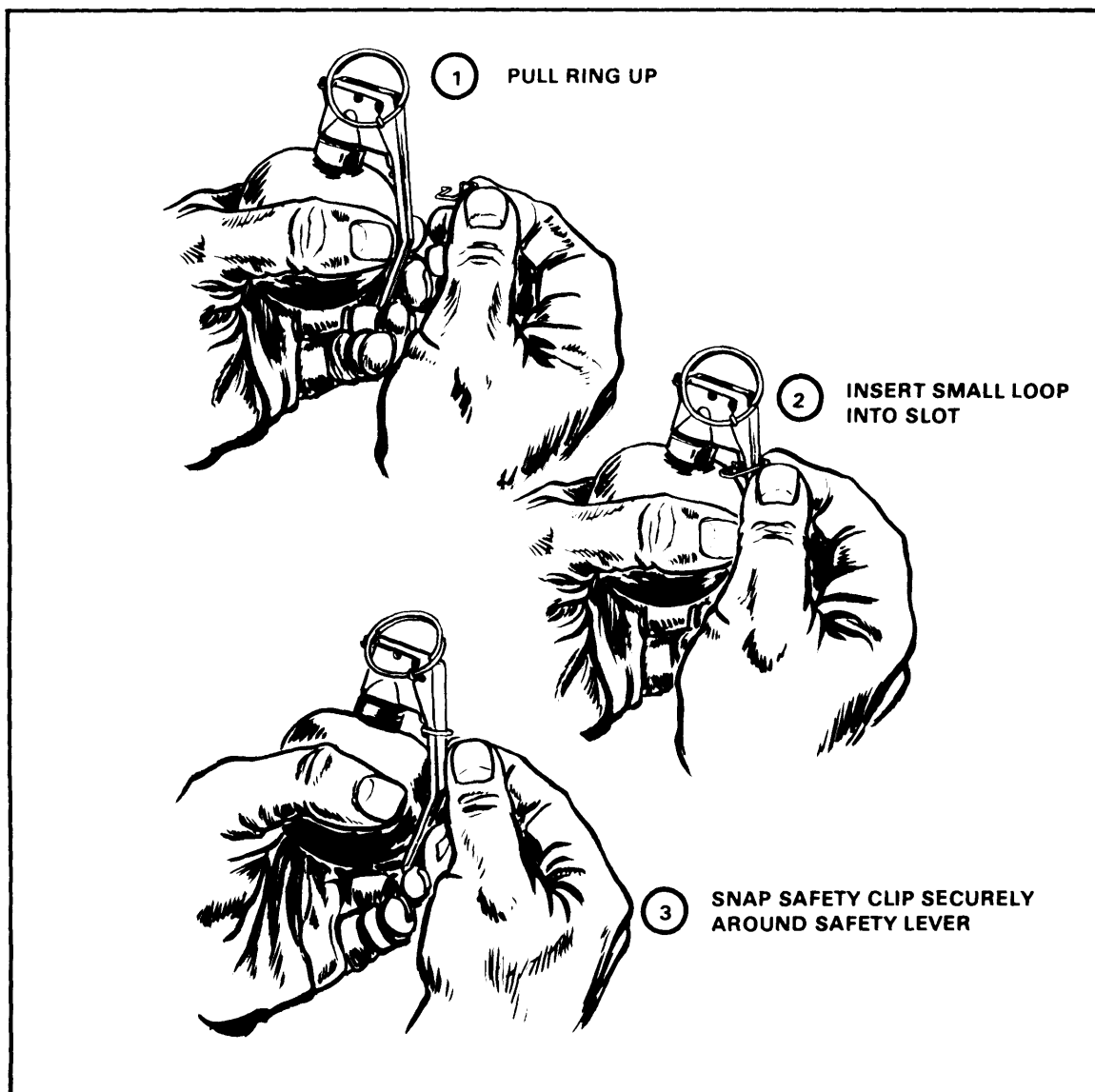

Figure 1-1. Safety clip insertion.

b. Remove the safety pin from the fuze by pulling the pull ring. Maintain pressure on the safety lever. Once the safety clip and safety pin assembly have been removed, the safety lever will spring free if pressure is not maintained.

c. Once pressure on safety lever is released, the striker will be forced to rotate on its axis by the striker spring, throwing the safety lever off.

d. The striker then detonates the primer.

e. The primer explodes, igniting the delay element.

f. The delay element burns for the prescribed amount of time (see Figure 1-2, and then it activates either the detonator or igniter.

g. The detonator or igniter acts to either explode or burn the filler substance (Figure 1-2).

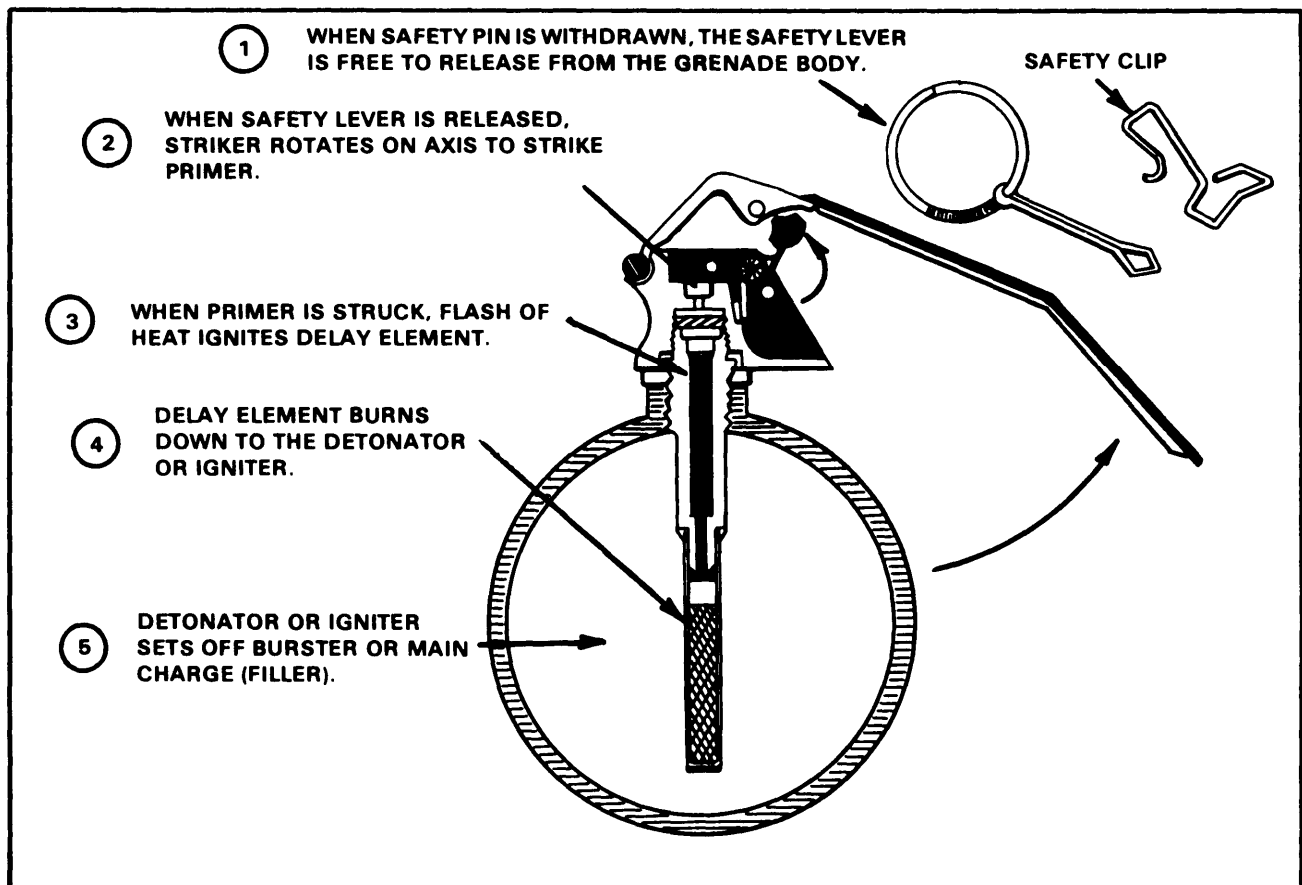

Figure 1-2. Fuze functioning.

**WARNING:** IF PRESSURE ON THE SAFETY LEVER IS RELAXED AFTER THE SAFETY CLIP AND SAFETY PIN HAVE BEEN REMOVED. IT IS POSSIBLE THAT THE STRIKER CAN ROTATE AND STRIKE THE PRIMER WHILE THE THROWER IS STILL HOLDING THE GRENADE. THIS IS CALLED "MILKING" THE GRENADE. THROWERS MUST BE INSTRUCTED TO MAINTAIN ENOUGH PRESSURE ON THE SAFETY LEVER SO THE STRIKER CANNOT ROTATE.

#### 1-4. FUZES

The two types of fuzes used in current US hand grenades are detonating and igniting. Both function in the same manner; the difference is how they activate the filler substance.

a. Detonating. Detonating fuzes explode within the grenade body to initiate the main explosion of the filler substance. Detonating fuzes include the M204A1, M204A2, M206A2, M213, and the C12 integral fuze.

(1) M204A1 and M204A2 fuzes (Figure 1-3). These fuzes are used with the M26 and M26A1 fragmentation grenades, which have been reclassified as the M61 under the product improvement program that added an attached safety clip feature. Each fuze functions as described in paragraph 1-3. The delay element is a powder train requiring 4 to 5 seconds to burn to the detonator. The detonator sets off the filler.

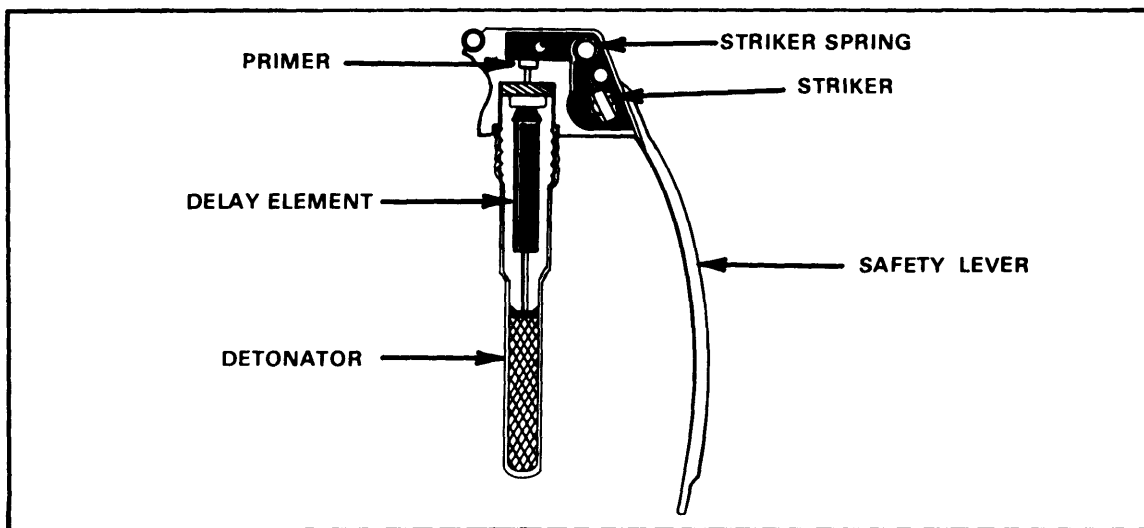

Figure 1-3. M204A2 fuze.



(2) M206A2 fuze (Figure 1-4). This fuze is used with the MK3A2 offensive hand grenade, commonly referred to as the concussion grenade. The M206-series of fuzes is similar to the M204-series, except for the safety lever. The M206 has a straight safety lever, while the M204 safety lever is curved. The delay element is a powder train requiring 4 to 5 seconds to burn to the detonator.

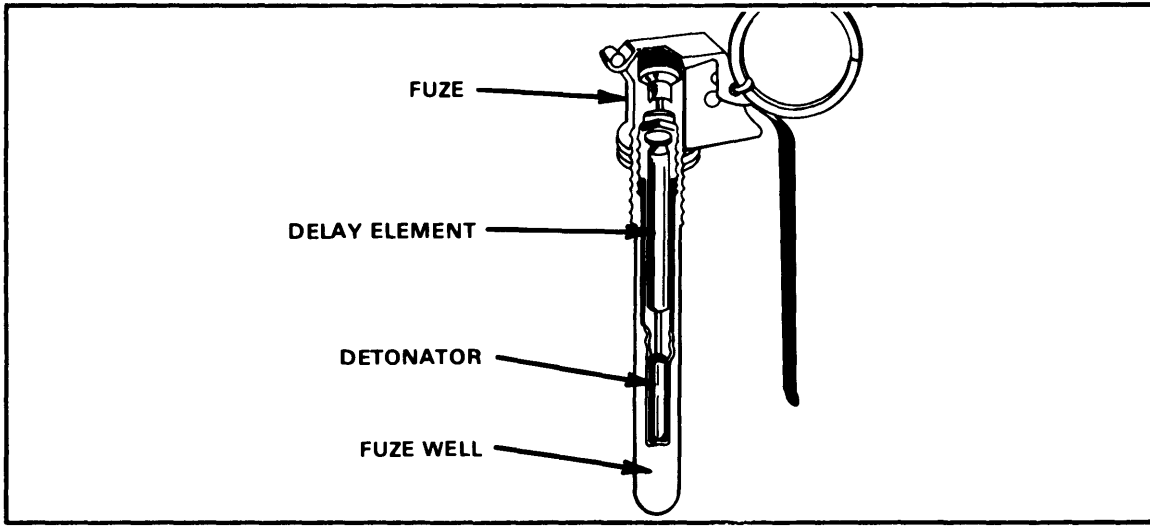

Figure 1-4. M206A2 fuze.

(3) M213 fuze (Figure 1-5). This fuze is used with the M67 fragmentation grenade. It has a safety clip. The delay element is a powder train requiring 4 to 5 seconds to burn to the detonator.

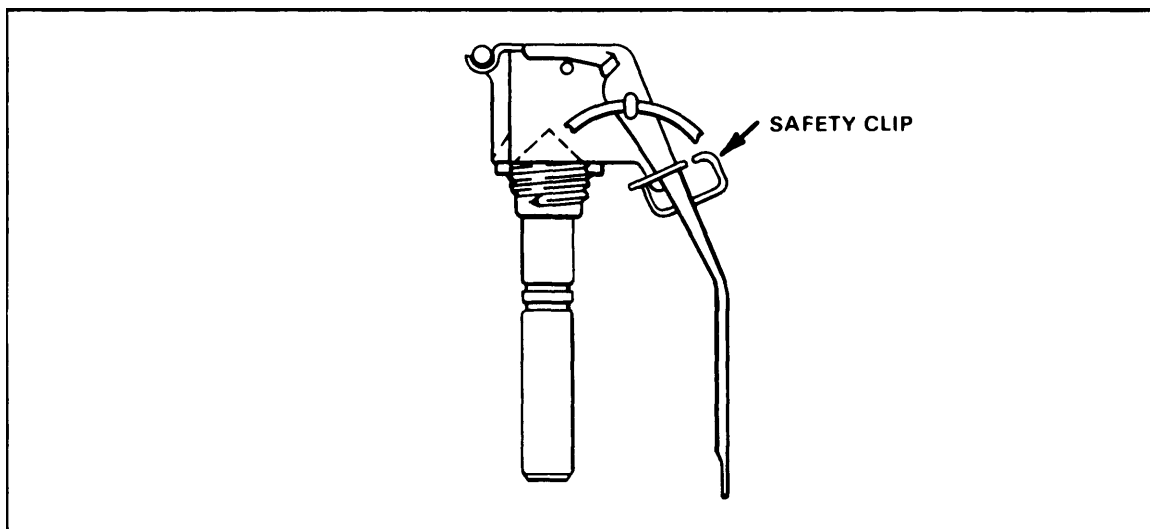

Figure 1-5. M213 fuze.

(4) C12 integral fuze (Figure 1-6). This fuze is an integral part of the M25-series riot control hand grenades. The fuze consists of a firing pin (screwed to the base of the grenade body), an arming sleeve, and a slider assembly. The slider assembly contains a delay element of 1.4 to 3 seconds and a small detonator. It functions as follows:

(a) When the safety pin is removed, the arming sleeve is held in place with the thumb.

(b) When the arming sleeve is released, the slider assembly is forced downward toward the firing pin under pressure of the firing spring.

(c) At the bottom of the fuze well, the slider strikes the firing pin and ignites the delay element which, in turn, sets off the detonator.

(d) The detonator bursts the grenade body and disperses the riot control agent over an area about 5 meters in diameter.

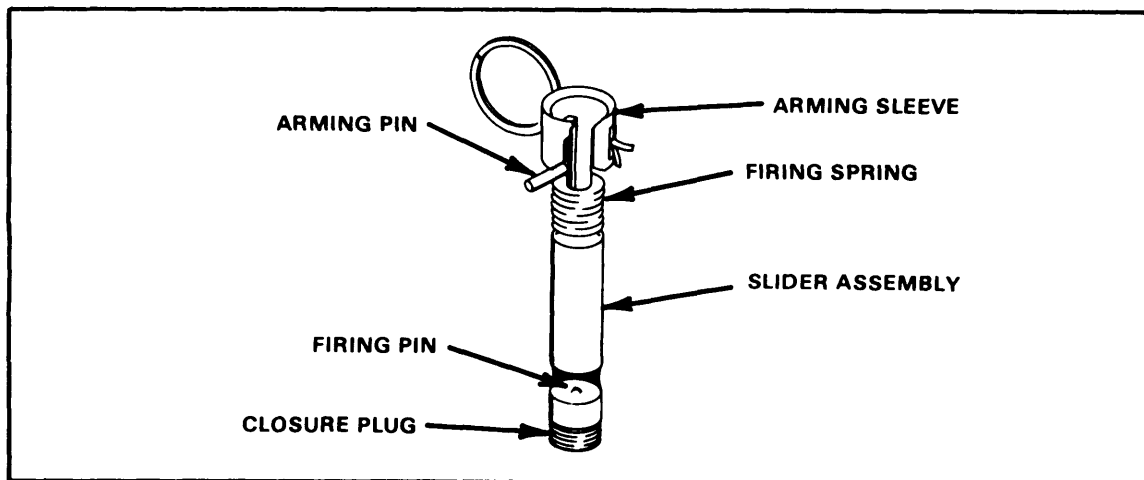

Figure 1-6. C12 integral fuze.

b. Igniting. Igniting fuzes are designed for use with chemical hand grenades. They burn at high temperatures and ignite the chemical filler.

(1) M201A1 fuze (Figure 1-7). This fuze is designed for use with the AN-M8HC white-smoke grenade, the AN-M14 TH3 incendiary grenade, and the M18 colored-smoke grenade. This fuze is interchangeable with any standard firing device. The fuze function is described in

paragraph 1-4. The time delay element is a powder train requiring 1.2 to 2 seconds to burn to the igniter. The igniter ignites the filler or a pyrotechnic starter with a violent burning action and forces the filler to be expelled from the grenade body.

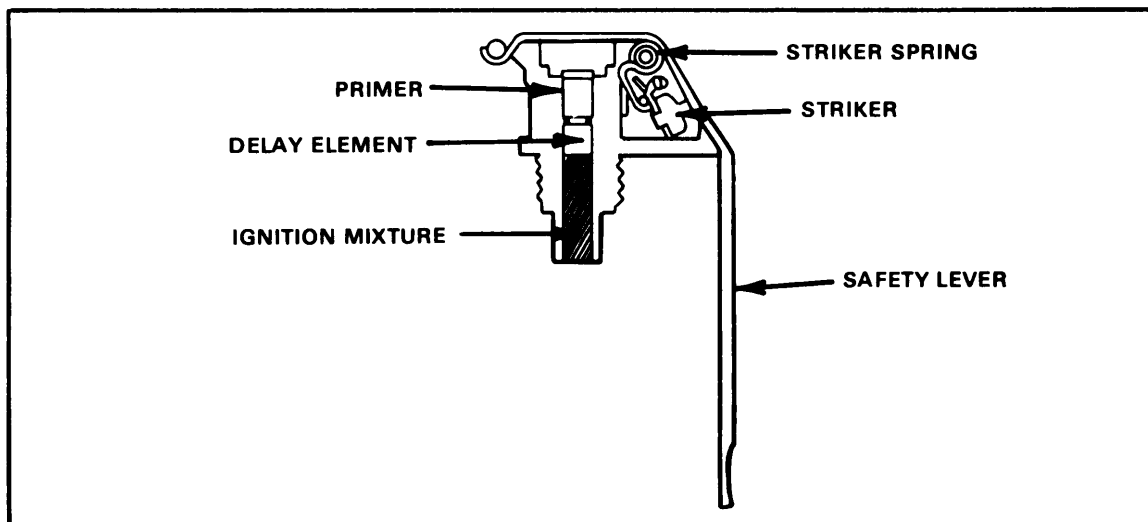

Figure 1-7. M201A1 fuze.

(2) M228 fuze (Figure 1-8). This fuze is used with the M62 and M69 practice hand grenades to replicate the fuze delay of the M67 fragmentation hand grenade. The time delay element is a powder train with a 4- to 5-second burn time. The igniter then induces the explosion of a black powder charge.

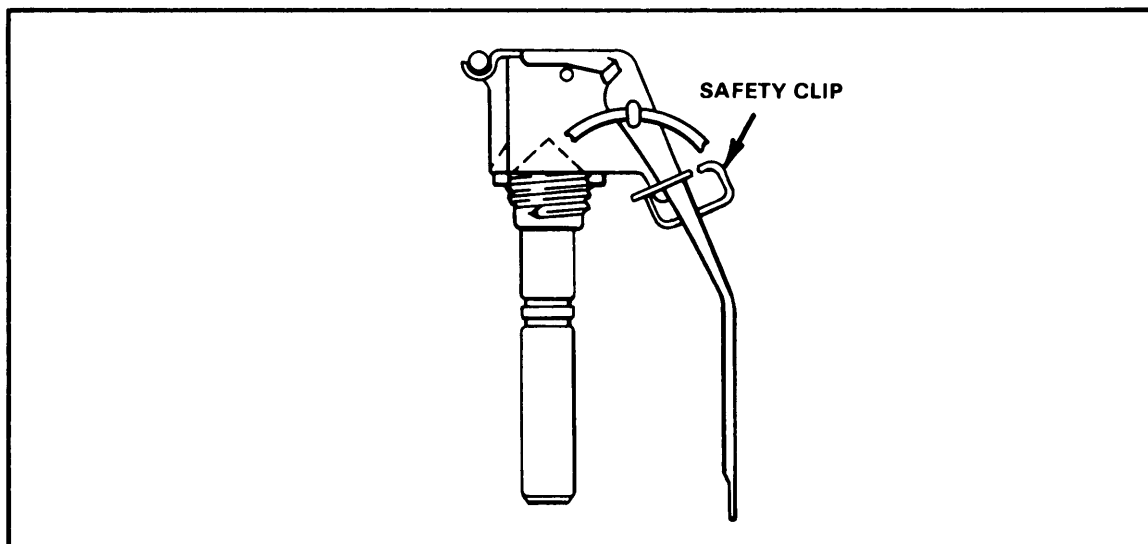

Figure 1-8. M228 fuze.

## 1.5 FRAGMENTATION HAND GRENADES

### a. M61 (Figure 1-9).

(1) Body -- thin sheet metal. Fragments are produced by a serrated wire coil fitted to the inside of the grenade body.

(2) Filler -- 5.5 ounces of Composition B.

(3) Fuze -- M204A1 or M204A2.

(4) Weight -- 16 ounces.

(5) Safety clip -- yes, see paragraph 1-3.

(6) Capabilities -- can be thrown 40 meters by average soldier. The effective killing radius is 5 meters and the effective casualty-producing radius is 15 meters.

(7) Color/markings -- olive drab body with a single yellow band at the top. Nomenclature and or lot number markings are in yellow.

**WARNING** ALTHOUGH THE KILLING RADIUS IS 5 METERS AND THE CASUALTY PRODUCING RADIUS OF THIS GRENADE IS 15 METERS, FRAGMENTS CAN DISPERSE AS FAR AWAY AS 230 METERS

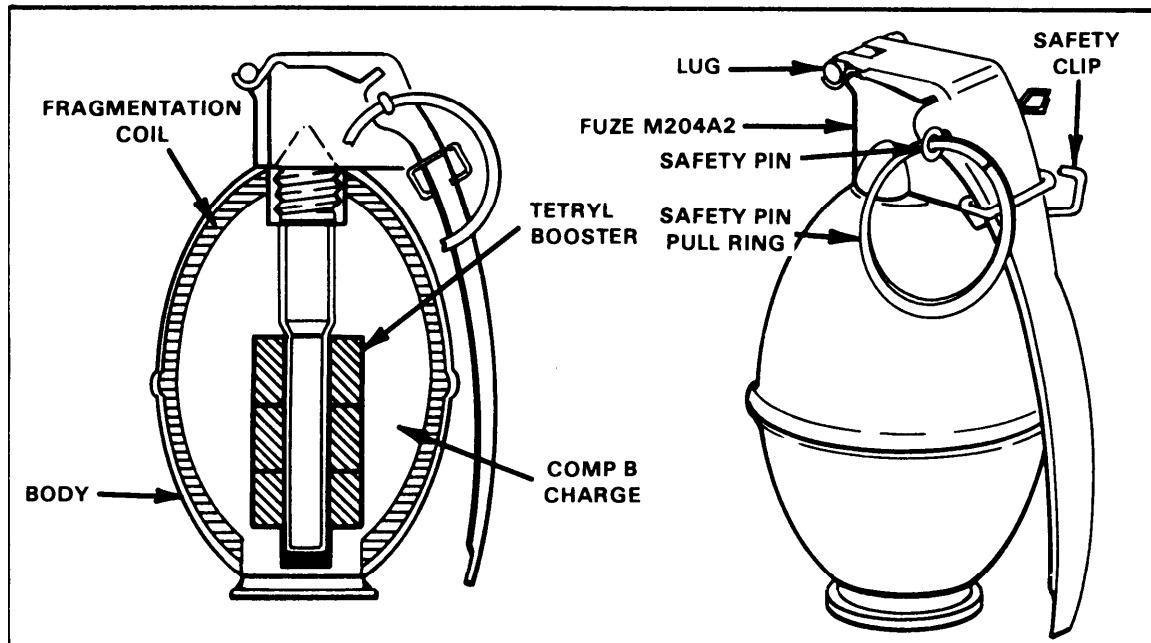

Figure 1-9. M61 fragmentation grenade.

b. M67 (Figure 1-10).

(1) Body -- steel sphere.

(2) Filler -- 6.5 ounces of Composition B.

(3) Fuze -- M213.

(4) Weight -- 14 ounces.

(5) Safety clip -- yes, see paragraph 1-3.

(6) Capabilities -- can be thrown 40 meters by average soldier. The effective casualty-producing radius is 15 meters.

(7) Color/markings -- olive drab body with a single yellow band at the top. Nomenclature and or lot number markings are in yellow.

**WARNING: ALTHOUGH THE KILLING RADIUS IS 5 METERS AND THE CASUALTY PRODUCING RADIUS OF THIS GRENADE IS 15 METERS, FRAGMENTS CAN DISPERSE AS FAR AWAY AS 230 METERS**

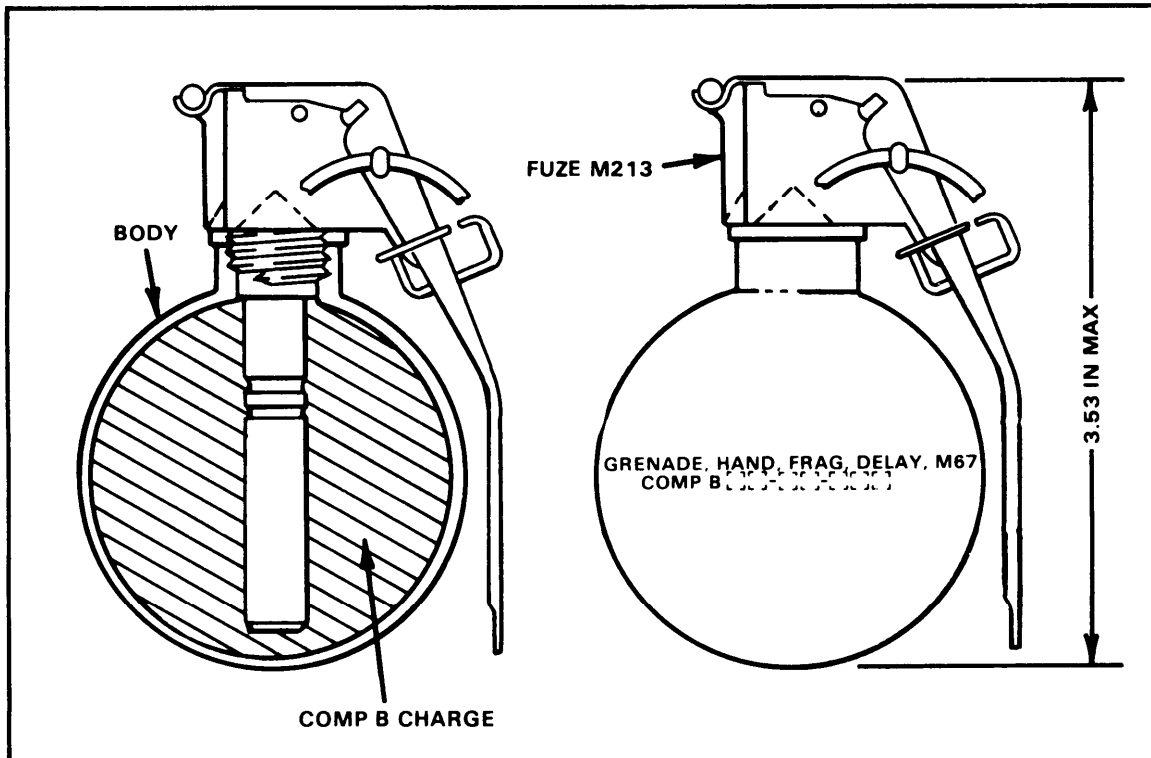

Figure 1-10. M67 fragmentation grenade.

## 1.6 CHEMICAL SMOKE HAND GRENADES

a. M15 White Phosphorous. The M15 grenade (Figure 1-11) is a bursting type grenade used for signaling, screening, and incendiary purposes.

(1) Body -- sheet metal.

(2) Filler -- 15 ounces of white phosphorus.

(3) Fuze -- M206A2.

(4) Weight -- 31 ounces.

(5) Capabilities -- the average soldier can throw the grenade 30 meters. The grenade has a bursting radius of 17 meters. All friendly personnel within this 17-meter area should be in a covered position to avoid being struck by burning particles. The WP filler burns for about 60 seconds at a temperature of 5,000 degrees Fahrenheit. This intense heat causes the smoke produced by the grenade to rise quite rapidly, especially in cool climates. This makes the M15 grenade less desirable for use as a screening agent.

(6) Color/markings -- grey with one yellow band and yellow markings.

(7) First aid -- treat burns caused by WP in the same way as ordinary burns (FM 21-11). If particles of WP are embedded in the flesh, immerse the wound in water or pack with wet cloths to halt combustion. Then pick out or squeeze out the WP. The particles will reignite spontaneously if allowed to dry. Apply copper sulphate solution to halt combustion of the WP particles. This permits them to be removed without igniting.

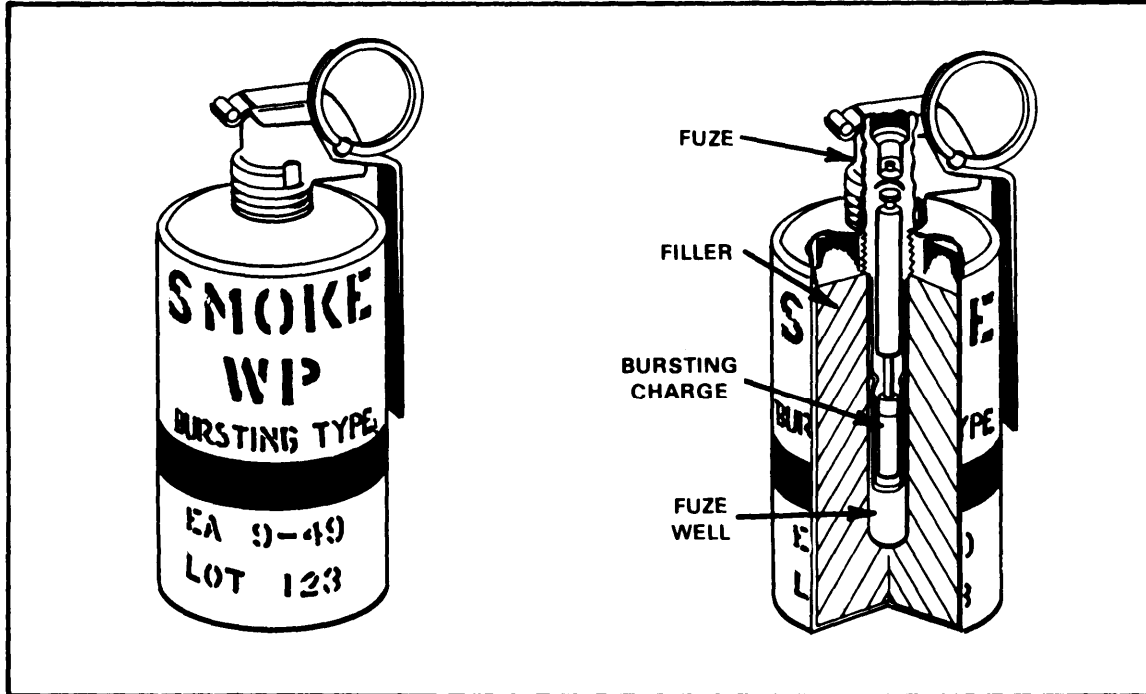

Figure 1-11. M15 WP smoke hand grenade.

b. AN-M8 HC White Smoke (Figure 1-12). This grenade is used to produce dense clouds of white smoke for signaling and screening.

- (1) Body -- sheet steel cylinder.
- (2) Filler -- 19 ounces of Type C, HC smoke mixture.
- (3) Fuze -- M201A1.
- (4) Weight -- 24 ounces.
- (5) Safety clip -- no.
- (6) Capabilities -- can be thrown 30 meters by average soldier. The grenade emits a dense cloud of white smoke for 105 to 150 seconds.
- (7) Color/markings -- light green body with black markings and a white top.

**WARNING: ANY DAMAGED AN M8 HC GRENADES THAT EXPOSE THE FILLER ARE HAZARDOUS EXPOSURE OF THE FILLER TO MOISTURE AND AIR COULD RESULT IN A CHEMICAL REACTION THAT WILL IGNITE THE GRENADE**

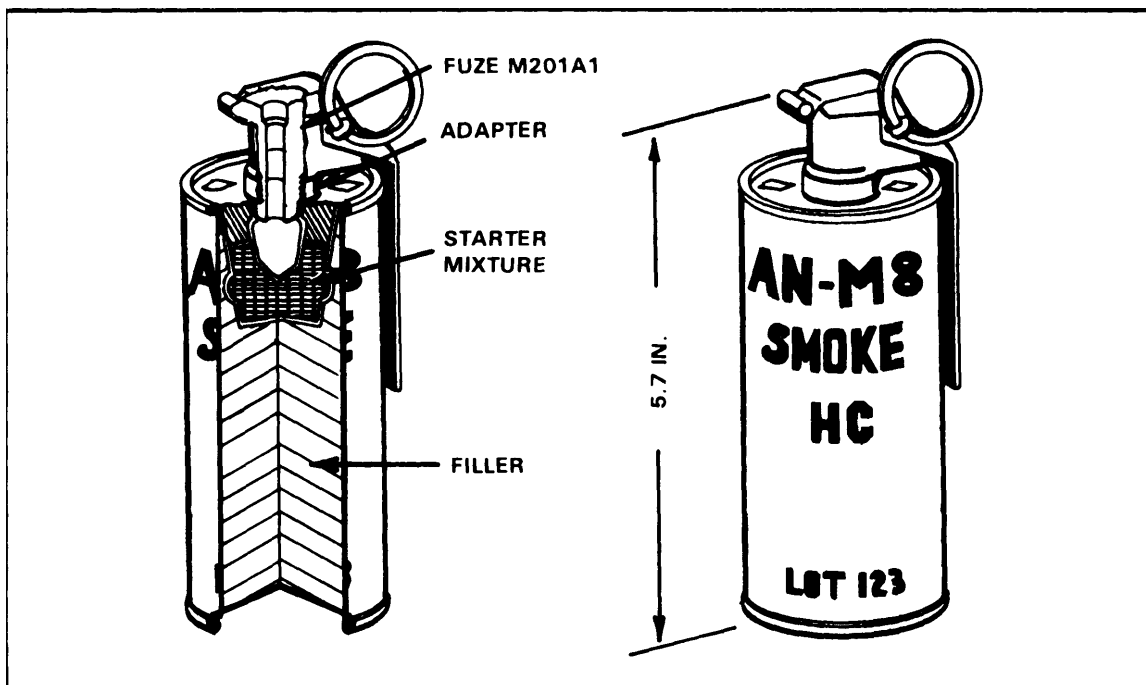

Figure 1-12. AN-M8 HC white smoke grenade.

**WARNING: THE AN M8 HAND GRENADE PRODUCES HARMFUL HYDROCHLORIC FUMES THAT IRRITATE THE EYES, THROAT, AND LUNGS IT SHOULD NOT BE USED IN CLOSED IN AREAS UNLESS SOLDIERS ARE WEARING PROTECTIVE MASKS**

c. M18 Colored Smoke (Figure 1-13). This grenade is used as a ground-to-ground or ground-to-air signaling device, a target or landing zone marking device, or a screening device for unit movements.

(1) Body -- sheet steel cylinder with four emission holes at the top and one at the bottom to allow smoke release when the grenade is ignited.

(2) Filler -- 11.5 ounces of colored smoke mixture (red, green, yellow, and violet).

(3) Fuze -- M201A1.

(4) Weight -- 19 ounces.

(5) Safety clip -- no.



(6) Capabilities -- can be thrown 35 meters by average soldier. The grenade produces a cloud of colored smoke for 50 to 90 seconds.

(7) Color/markings -- olive drab body with the top indicating the smoke color.

(8) Field expedient -- When employing the M18 or AN-M8 HC hand grenade, it may be desirable to use one of these grenades without the fuze. To do this, the following procedure should be used in combat only:

- o Remove the tape from grenade bottom to expose the filler.
- o Remove the fuze by unscrewing it from the grenade.
- o Ignite starter mixture with open flame.
- o Immediately throw the grenade to avoid burn injury.

**WARNING: WITH BOTH THE AN M8 AND AN-M18, THERE IS DANGER OF STARTING A FIRE IF USED IN A DRY AREA**

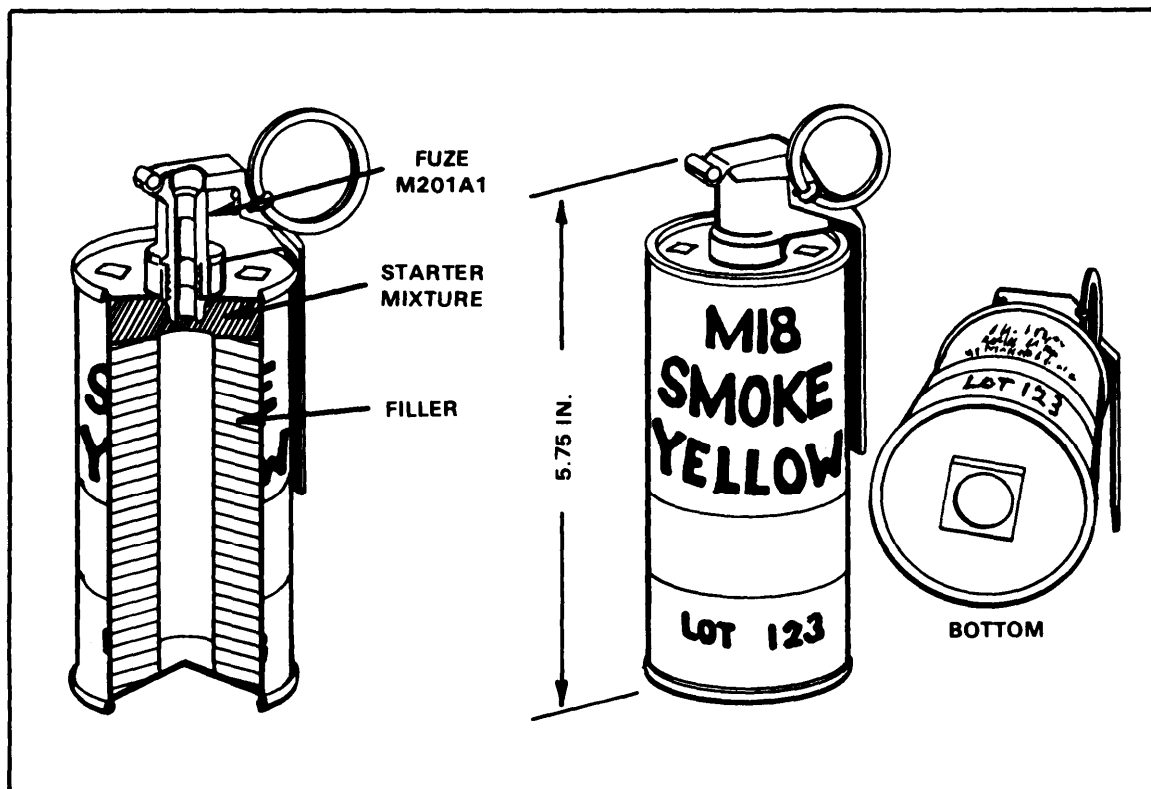

Figure 1-13. M18 colored smoke grenade.

## 1.7 RIOT CONTROL HAND GRENADES

a. ABC-M7A2 and ABC-M7A3 CS (Figure 1-14). The ABC-M7A2 and the ABC-M7A3 riot control hand grenades contain only CS as a filler. They differ only in the amount of filler and the form of the CS they contain.

(1) Body -- the bodies of both grenades are sheet metal with four emission holes at the top and one at the bottom.

(2) Filler -- 5.5 ounces of burning mixture and 3.5 ounces of CS in gelatin capsules in the ABC-M7A2 grenade, and 7.5 ounces of burning mixture and 4.5 ounces of pelletized CS agent in the ABC-M7A3 grenade.

(3) Fuze -- M201A1, see paragraph 1-4.

(4) Weight -- approximately 15.5 ounces.

(5) Safety clip -- no.

(6) Capabilities -- can be thrown 40 meters by average soldier. Both grenades produce a cloud of irritant agent for 15 to 35 seconds.

(7) Color/markings -- gray body with a red band and red markings.

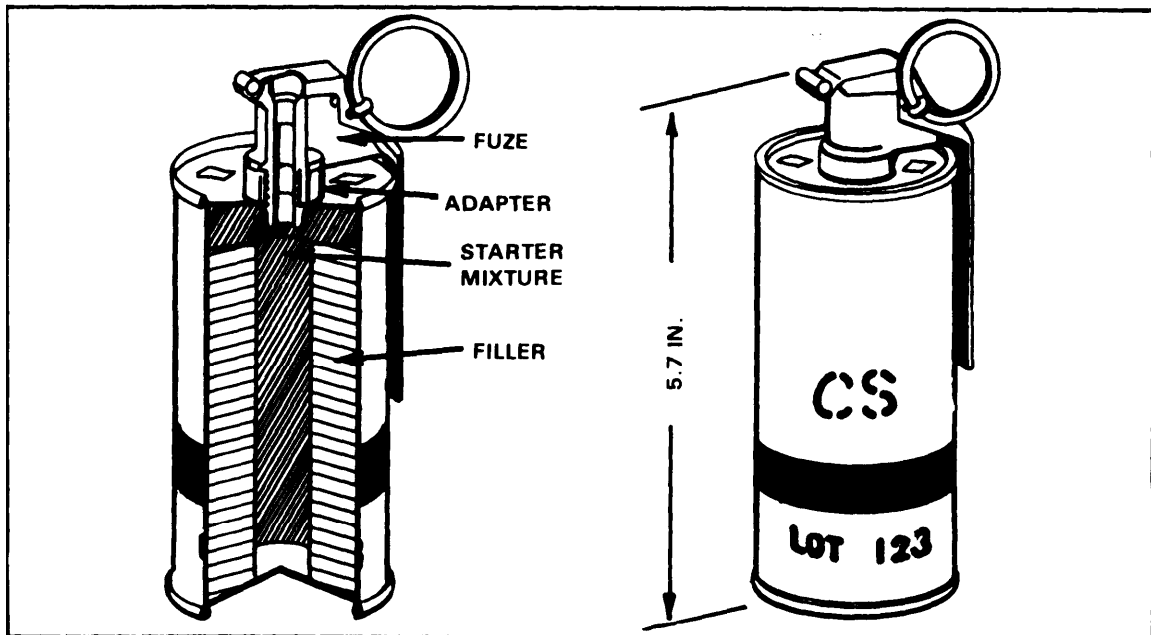

Figure 1-14. ABC-M7A2 and ABC-M7A3 riot control grenades.

**WARNING: FRIENDLY FORCES SHOULD PUT ON PROTECTIVE MASKS BEFORE THROWING THESE GRENADES**

b. ABC-M25A2 (Figure 1-15). The ABC-M25A2 riot control hand grenade is a bursting munition with an integral fuze. The M25A2 grenade is an improved version of the M25A1 grenade. The two grenades differ primarily in body construction.

- (1) Body -- compressed fiber or plastic.
- (2) Filler -- CS1 varies in weight and composition according to the type of agent contained in the grenade. All fillers are mixed with silica aerogel for increased dissemination efficiency.
- (3) Fuze -- integral, see paragraph 1-4.
- (4) Weight -- 8 ounces.
- (5) Safety clip -- no.
- (6) Capabilities -- can be thrown 50 meters by average soldier. The radius of burst (visible cloud agent) is about 5 meters, but grenade fragments may project as far as 25 meters.
- (7) Color/markings -- gray body with red band and red markings.

**WARNING: FRIENDLY FORCES SHOULD PUT ON PROTECTIVE MASKS BEFORE THROWING THESE GRENADES**

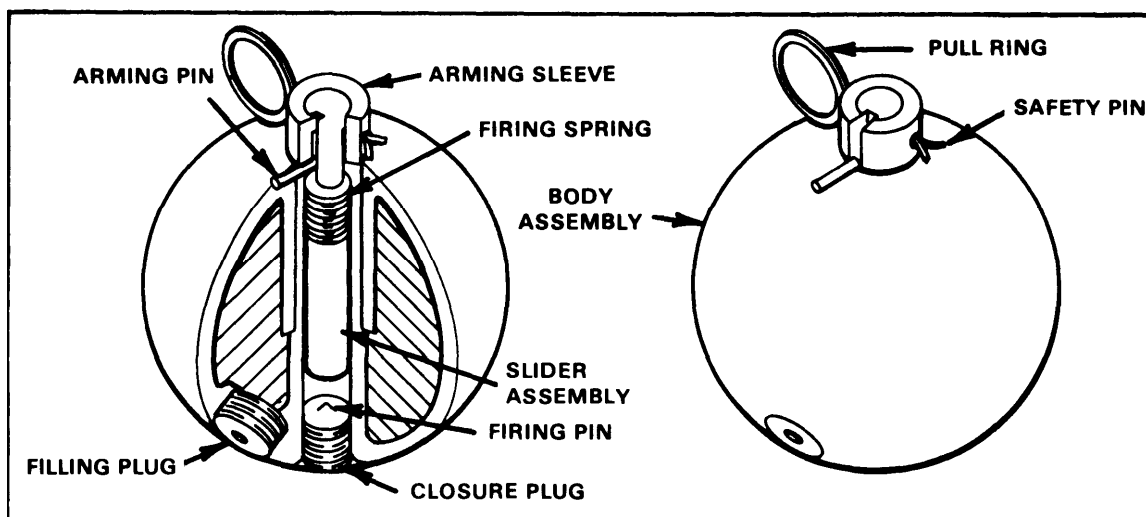

Figure 1-15. ABC-M25A2 riot control grenade.

1-8. SPECIAL-PURPOSE HAND GRENADES

a. Incendiary (Figure 1-16). The AN-M14 TH3 incendiary hand grenade is used to destroy equipment. It can damage, immobilize, or destroy vehicles, weapons systems, shelters, or munitions. The grenade may also be used to start fires in areas containing flammable materials.

(1) Body -- sheet metal.

(2) Filler -- 26.5 ounces of thermate (TH3) mixture.

(3) Fuze -- M201A1, see paragraph 1-4.

(4) Weight -- 32 ounces.

(5) Safety clip -- no.

(6) Capabilities -- can be thrown 25 meters by average soldier. A portion of the thermate mixture is converted to molten iron, which burns at 4,000 degrees Fahrenheit. It will fuze together the metallic parts of any object that it contacts. Thermate is an improved version of thermite, the incendiary agent used in hand grenades during World War II. The thermate filler of the AN-M14 grenade burns for 40 seconds and can burn through a 1/2-inch homogeneous steel plate. It produces its own oxygen and will burn under water.

(7) Color/markings -- gray with purple markings and a single purple band (current grenades). Under the standard color-coding system, incendiary grenades are light red with black markings.

**WARNING: AVOID LOOKING DIRECTLY AT THE INCENDIARY GRENADE AS IT BURNS.  
THE INTENSITY OF THE LIGHT IS POTENTIALLY HAZARDOUS TO THE  
RETINA**

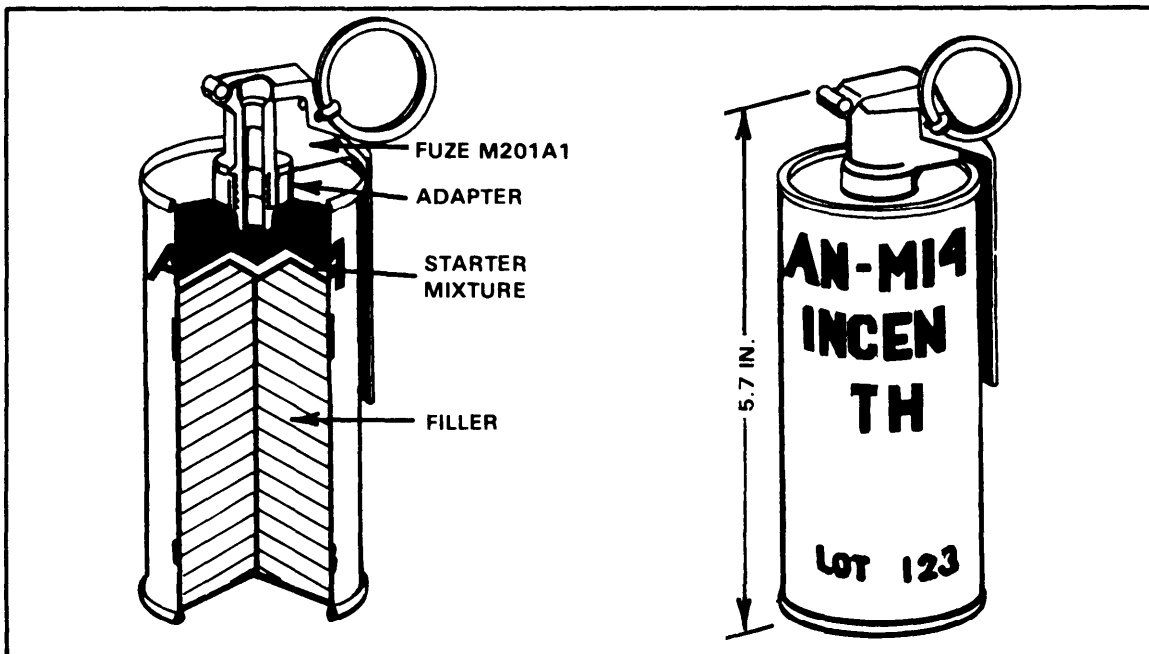

Figure 1-16. AN-M14 TH3 incendiary grenade.

b. Offensive (Figure 1-17). The MK3A2 offensive hand grenade, commonly referred to as the concussion grenade, is designed to produce casualties during close combat while minimizing danger to friendly personnel. The grenade is also used for concussion effects in enclosed areas, for blasting, or for demolition tasks. The shock waves (overpressure) produced by this grenade when used in enclosed areas are greater than those produced by the fragmentation grenade. It is, therefore, very effective against enemy soldiers located in bunkers, buildings, and fortified areas.

- (1) Body -- fiber (similar to the packing container for the fragmentation hand grenade).
- (2) Filler -- 8 ounces of TNT.
- (3) Fuze -- M206A1 or M206A2, see paragraph 1-4.
- (4) Weight -- 15.6 ounces.
- (5) Safety clip -- yes, see paragraph 1-3.
- (6) Capabilities -- can be thrown 40 meters by average soldier. The MK3A2 has an effective casualty radius in open areas of 2 meters. Secondary missiles and bits of fuze may be projected as far as 200 meters from the detonation point.

(7) Color/markings -- black with yellow markings around its middle.

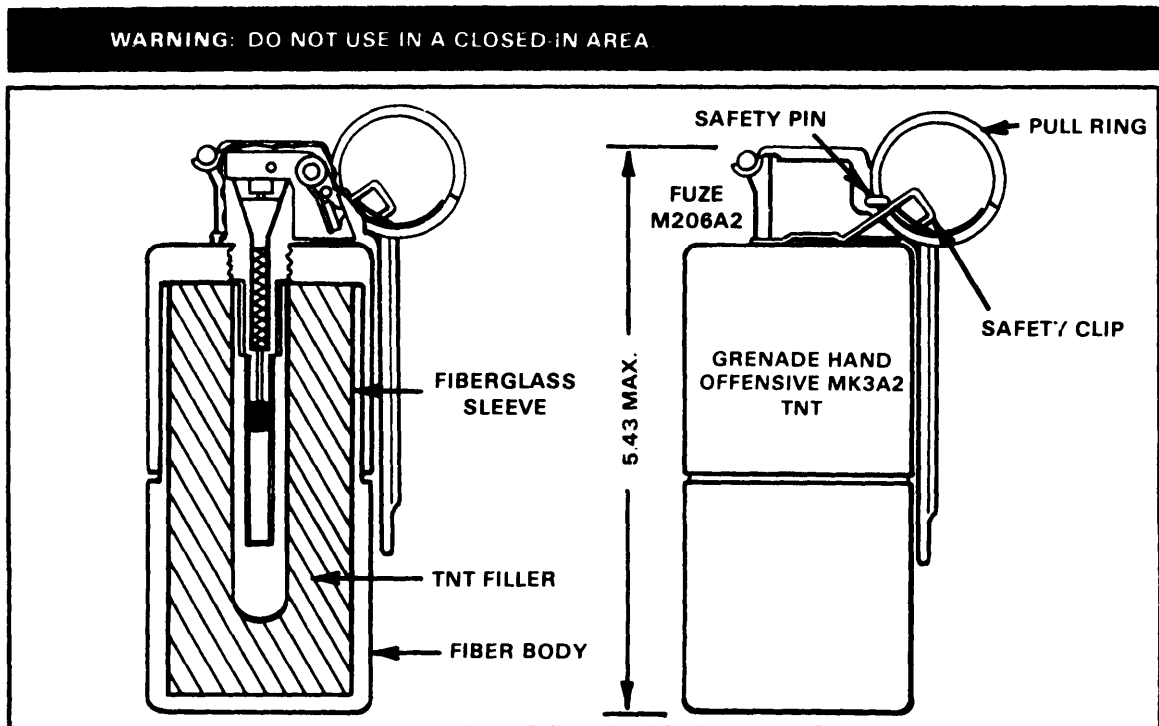

Figure 1-17. MK3A2 offensive grenade.

c. Practice (Figure 1-18). the M69 practice hand grenade simulates the M67-series of fragmentation hand grenades for training purposes. The grenade provides realistic training and familiarizes the soldier with the functioning and characteristics of the fragmentation hand grenade.

- (1) Body -- steel.
- (3) Fuze -- M228, inserted into grenade body.
- (4) Weight -- 14 ounces.
- (5) Safety clip -- yes.
- (6) Capabilities -- can be thrown 40 meters by average soldier. The M69 grenade emits a small puff of white smoke after a delay of 4 to 5 seconds and makes a loud popping noise. The grenade body can be used repeatedly by replacing the fuze assembly.
- (7) Color/markings -- light blue with white markings. The safety lever of the fuze is light blue with black markings and a brown tip.

**WARNING: FUZE FRAGMENTS MAY EXIT THE HOLE IN THE BASE OF THE GRENADE BODY CAUSING INJURIES**

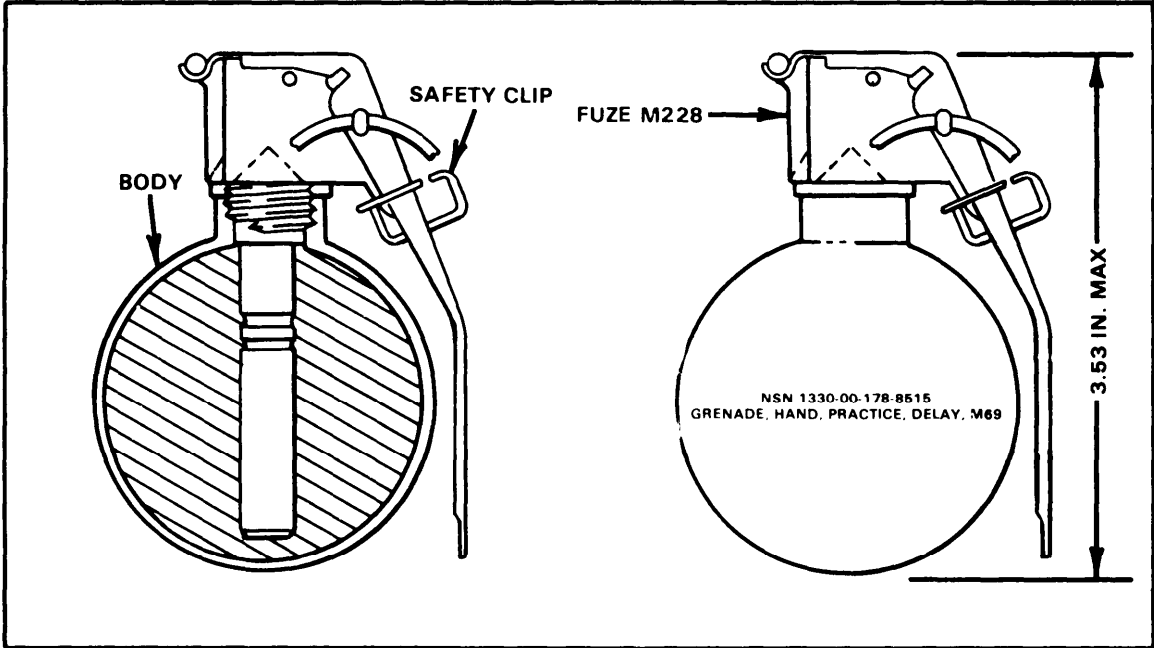

Figure 1-18. M69 practice grenade.

## CHAPTER 2

## UTILIZATION OF GRENADES

The hand grenade is an extremely effective and versatile device that is easily carried. The tactical employment of the hand grenades is limited only by the imagination of the user. Its versatility makes its use suitable for all operations. This chapter addresses the fundamentals that will develop a soldier's skill and confidence in hand grenade use. These fundamentals include proper carrying, gripping, and throwing techniques of hand grenades. They provide the foundation upon which the soldier's hand grenade skills will build.

## 2-1. HAND GRENADE CARRYING

The carrying of hand grenades is one of the most neglected aspects of hand grenade training. Experiences of American infantrymen, both in combat and in training point out the need for specific training in carrying hand grenades and the integration of this type of training into tactical training exercises. Commanders should make every effort to issue training hand grenades for wear and use during all training activities. The soldier must be as confident in carrying and using hand grenades as he is with his rifle and bayonet.

a. Precautions. Before attaching a hand grenade to the ammunition pouch, take the following safety precautions.

(1) Check the grenade fuze assembly for tightness. It must be tightly fitted in the grenade fuze well to prevent the grenade from working loose and separating from the grenade body. The fuze should never be removed from a grenade unless the the grenade is being used as a booby trap with some other firing device.

(2) If the grenade safety lever is broken, do not use the grenade. A broken safety lever denies the thrower the grenade's most critical safety mechanism.

(3) Do not bend the ends of the safety pin back flush against the fuze body. This practice, intended to preclude accidental pulling of the pi, makes the removal of the safety pin difficult. Repeated working of the safety pin in this manner will cause the pin to break, creating a hazardous condition.



b. Ammunition Pouch. The prescribed manner of carrying hand grenades is on the ammunition pouch, using the carrying straps, which are designed specifically for this purpose. Grenades are attached to the ammunition pouch in the following manner:

(1) New-style ammunition pouches (Figure 2-1). Open the web carrying sleeve on the side of the ammunition pouch and slide the grenade into the sleeve with the safety lever against the side of the ammunition pouch. Be sure the pull ring is in the downward position. Wrap the carrying strap around the neck of the fuze and snap the carrying strap to the carrying sleeve.

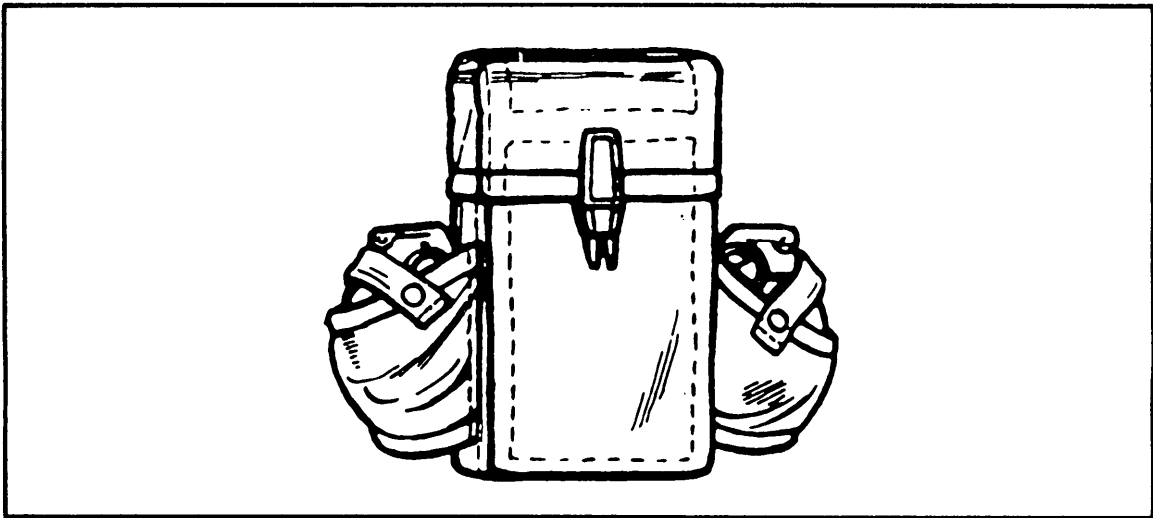

Figure 2-1. New-style pouch.

(2) Old-style ammunition pouches (Figure 2-2). A small strap is sewn to each side of the ammunition pouch. Slip the safety lever over this strap and push the grenade down until it is firmly seated against the side of the pouch. Ensure the pull ring is in the downward position, wrap the carrying strap around the fuze, and snap the carrying strap. Periodically check the grenade to ensure the fuze is tight and the carrying strap is secure.

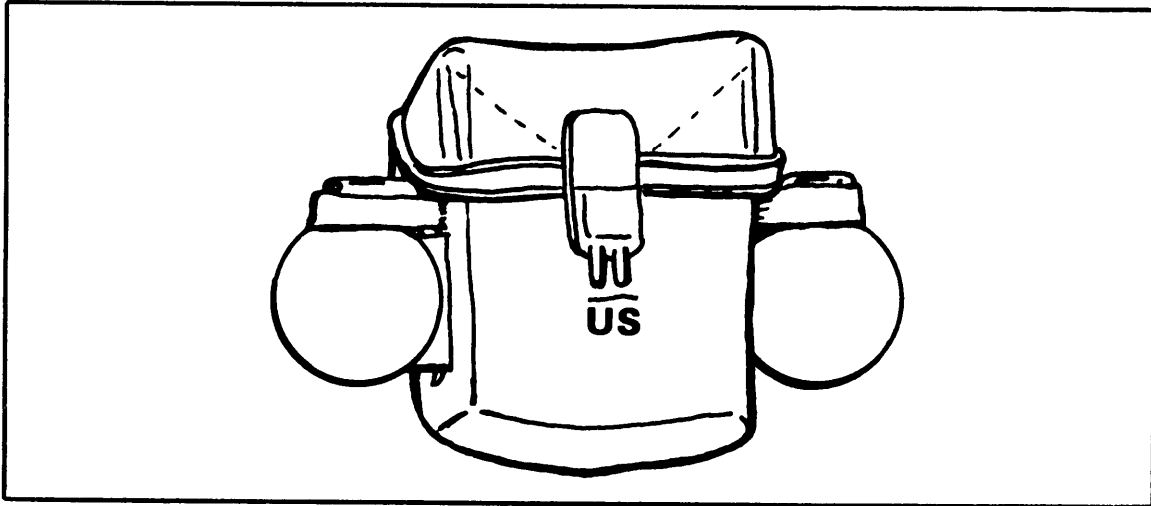

Figure 2-2. Old-style pouch.

## 2-2. HAND GRENADE GRIPPING

The importance of properly gripping the hand grenade cannot be overemphasized.

- a. Safety and throwing efficiency are obtained when the grenade is held in the throwing hand with the safety lever placed between the first and second joints of the thumb (Figure 2-3).
- b. For right-handed personnel, the grenade is held upright with the pull ring away from the palm of the throwing hand so that it can be easily removed by the index finger or middle finger of the free hand (Figure 2-3).

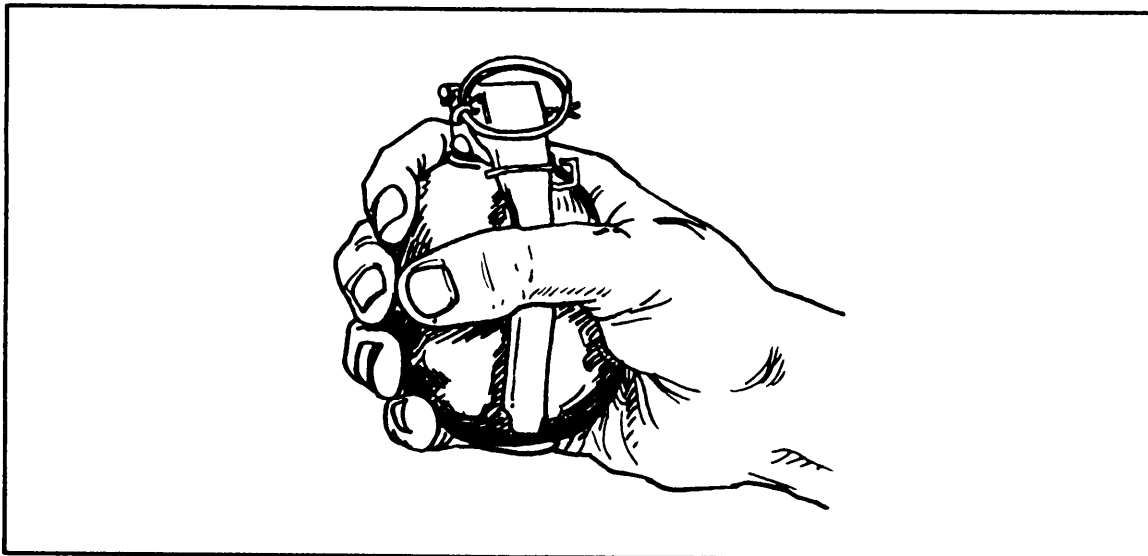

Figure 2-3. Right-handed grip.

c. For left-handed personnel, the grenade is inverted with the fingers and thumb of the throwing hand positioned in the same manner as by right-handed personnel (Figure 2-4),

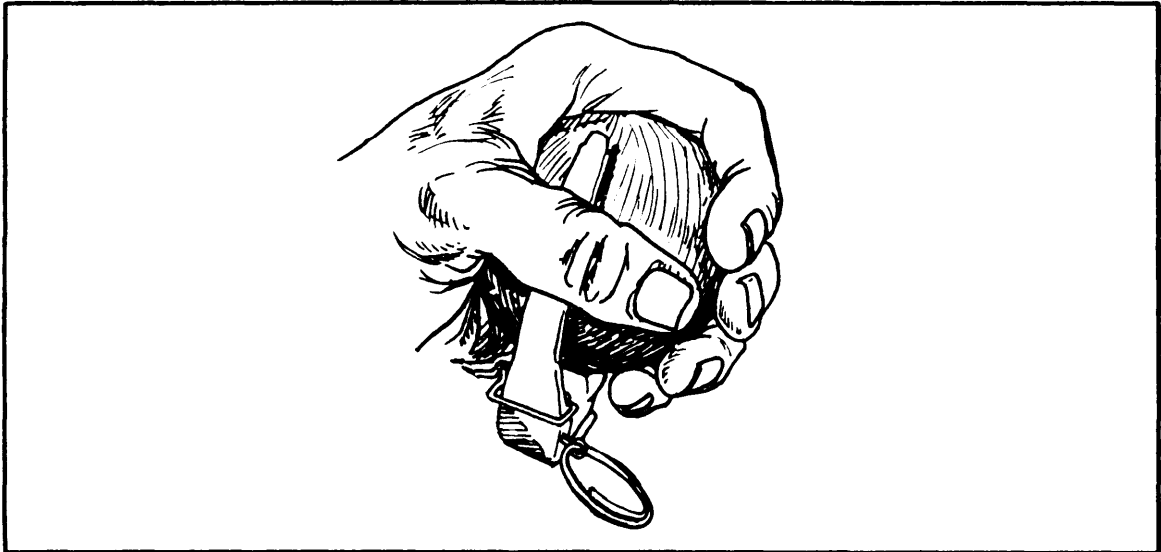

Figure 2-4. Left-handed grip.

**WARNING: LEFT-HANDED PERSONNEL MUST MAKE SURE THEY HOLD SMOKE GRENADES AWAY FROM THEIR FACE**

d. The M24-series of riot control hand grenades have an arming sleeve, which serves as the safety lever on other grenades. When throwing these grenades, the arming sleeve is held in place by applying constant pressure with the thumb of the throwing hand (Figure 2-5). The safety pin is pulled by the free hand.

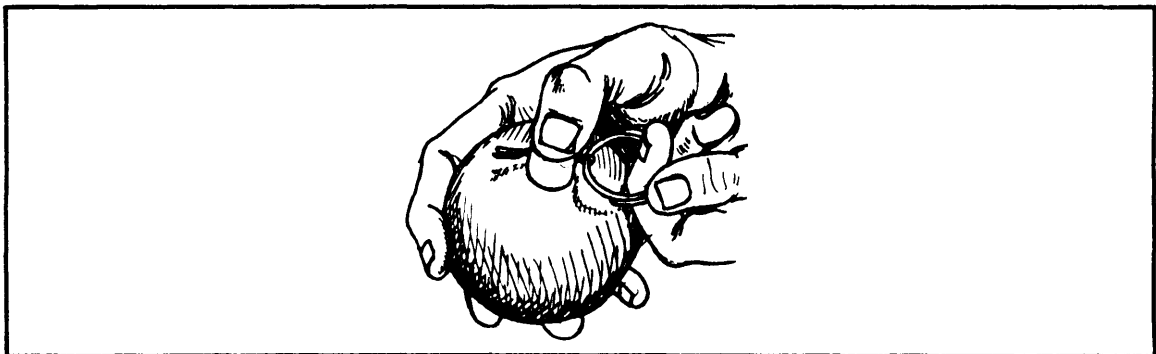

Figure 2-5. M24-series grip.

## 2-3. HAND GRENADE THROWING

Since few soldiers throw in the same manner, it is difficult to establish firm rules or techniques for throwing hand grenades. How accurately it is thrown is more important than how it is thrown. If a soldier can achieve more distance and accuracy using his personal style, then he should be allowed to do so.

a. There is, however, a recommended method of grenade throwing. Practice will develop throwing proficiency. In observing the target, minimize exposure time to the enemy (no more than 2 seconds).

(1) Quickly observe the target to mentally establish the distance between the throwing position and the target area.

(2) Properly grip the grenade in throwing hand and remove the safety clip.

(3) Grasp the pull ring with the index or middle finger of your nonthrowing hand. Remove the safety pin with a pulling, twisting motion. (If the tactical situation permits, observe the safety pin's removal.)

(4) Quickly look at the target and throw the grenade using the overhand method so that the grenade arcs, landing on or near the target.

(5) Allow the motion of your throwing arm to continue naturally once the grenade is released. This follow-through improves distance and accuracy and relieves the strain on your throwing arm.

NOTE: There will be times when underhand or sidearm throws become necessary in combat. These throws may be practiced with training grenades; however, the live fragmentation grenade must be thrown overhand in a training environment.

b. In training, throwing positions are used for uniformity and control and to familiarize soldiers with the proper manner of throwing grenades in combat if the situation gives you a choice.

(1) Standing (Figure 2-6). This position is the most desirable and natural one from which to throw grenades. It allows an individual to obtain the greatest possible throwing distance. The standing position is normally used when occupying a fighting position or during

operations in fortified positions or urban terrain. Throwing from this position is accomplished as follows:

(a) Assume a natural stance with your weight balanced equally on both feet. Using the proper grip, hold the grenade shoulder high.

(b) Throw the grenade with a natural motion, using the procedure described in paragraph 2-2a.

(c) Seek cover to avoid being hit by fragments. If no cover is available, drop to the prone position with your helmet facing the direction of the grenade's detonation.



Figure 2-6. Standing.

(2) Kneeling (Figure 2-7). this position reduces the distance that a grenade can be thrown. It is used primarily when the soldier has only a low wall, a shallow ditch, or similar cover to protect him. Throwing from this position is accomplished as follows:

(a) Using the proper grip and with the grenade held shoulder high, kneel in the most comfortable manner.

(b) Throw the grenade with a natural throwing motion. Push off with your trailing foot to give added force to your throw.

(c) When the grenade is released, drop to the prone position or behind available cover to minimize exposure to fragmentation.



Figure 2-7. Kneeling.

(3) Prone (Figure 2-8). This position reduces both distance and accuracy. It is only used when an individual is pinned down by hostile fire and is unable to rise to engage his target. There are four steps in the process of throwing from a prone position.

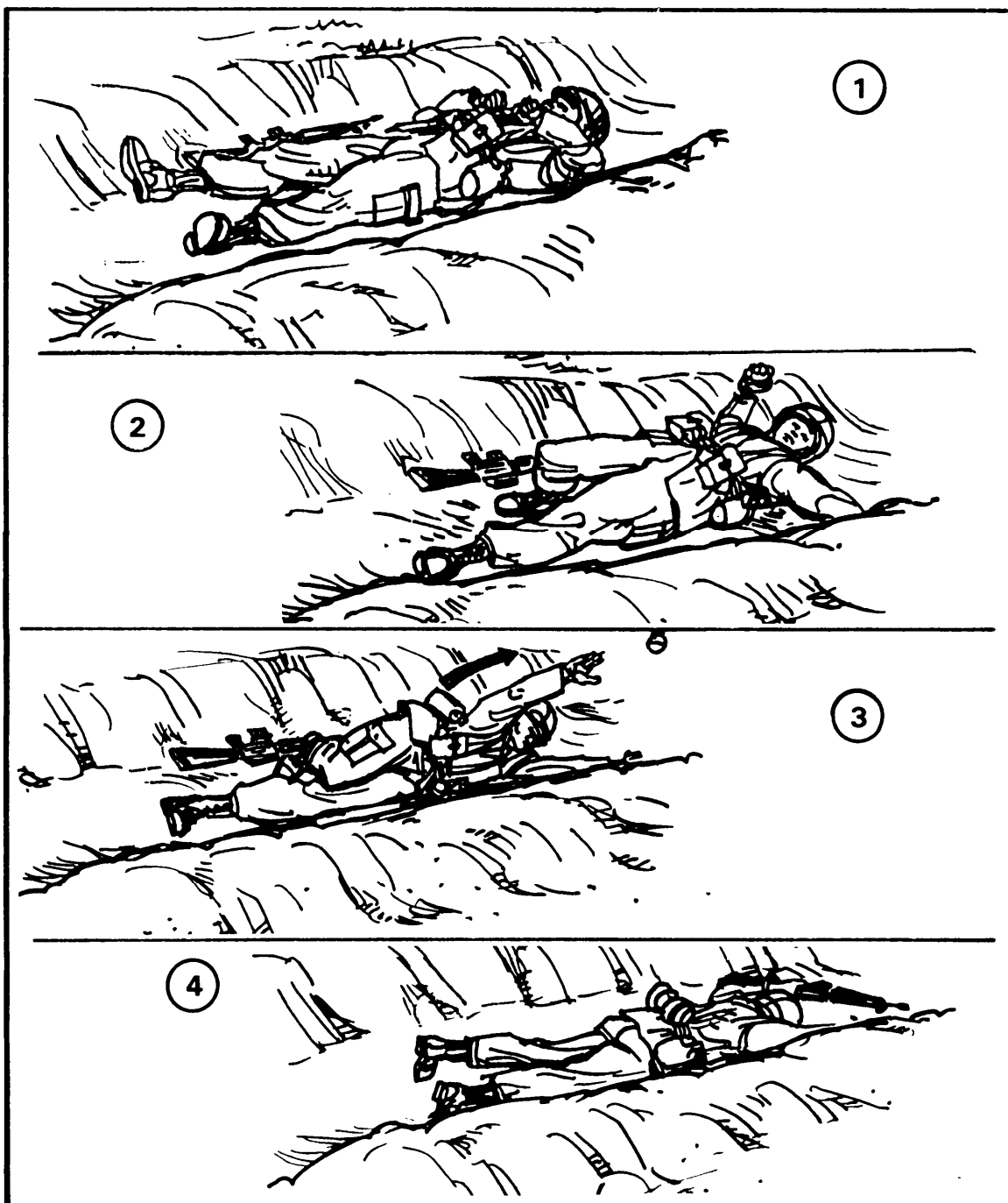

Figure 2-8. Prone.

Step 1. Lie on your back with your body perpendicular to the grenade's intended line of flight. Hold the grenade at shoulder level as in the standing position.

Step 2. Cock your right leg (left leg for a left-handed thrower) with your foot braced firmly against the ground. After removal of the safety pin, hold the grenade away from your body with your arm cocked for throwing.

Step 3. With your free hand, grasp any object that is capable of giving you added leverage to increase your throwing distance. In throwing the grenade, push off with your rearward foot to give added power to your throw.

Step 4. After throwing the grenade, roll over onto your stomach and press yourself flat against the ground.



## CHAPTER 3

## TACTICAL EMPLOYMENT OF GRENADES

The family of hand grenades provides the individual soldier with a number of highly versatile and effective weapons systems. Hand grenades are employed throughout the spectrum of warfare, from low- to high-intensity conflict to prevent giving away positions, to save ammunition, and to inflict greater casualties.

## 3-1. APPLICATION

a. Hand grenades are used on all missions -- attack, defend, and retrograde. Hand grenades are used by all soldiers during close, deep, and rear operations, during all conditions of combat, and in all types of terrain. Hand grenades have the following specific applications:

<u>TYPE</u>	<u>USE</u>
Fragmentation Offensive	Kill enemy soldiers. Kill, stun, and disable enemy soldiers.
Incendiary	Destroy weapons, vehicles, and equipment.
Smoke	Obscure, mark, and identify positions.
Riot control	Disable riots.

b. While all hand grenades have application in modern combat, the fragmentation grenade remains the most important. It is the most important not only because it is the primary killing hand grenade, but because it is also the most dangerous to employ. It is equally lethal to friendly and enemy soldiers; therefore, it must be employed under control to protect our own soldiers.

## 3-2. CLOSE COMBAT

The rifle, bayonet, and fragmentation hand grenades are the basic weapons of warfare for the individual soldier. The rifle gives the soldier the ability to kill enemy soldiers with direct fires out to the maximum effective line-of-sight range. Fragmentation hand grenades, on the other hand, allow the individual soldier to effectively engage and kill enemy soldiers located within a radius of 40 meters when line-of-sight systems, such as the rifle, are no longer effective. While the rifle is the safest and most discriminating weapon at close-in ranges, the fragmentation hand

grenade is the weapon of choice when the enemy is within range, but terrain masks the engagement area. The fragmentation hand grenade is the soldier's personal indirect fire weapons system. For a soldier, the close-in fight can occur anywhere on the modern battlefield.

a. Many times in combat, targets confronting the infantryman may be of such a nature that normal methods of target engagement are inadequate. For example, soldiers or weapons in trenches or fighting positions are better engaged by causing a grenade to burst over these targets. Furthermore, if the targets are located on sloping ground, it would then be desirable to detonate a grenade as near impact as possible to prevent its rolling away from the target before the time delay is expended. Such above ground detonation also prevents the enemy from securing the grenade and throwing it back before it detonates.

b. Above ground detonation is especially critical when bunker-type emplacements are engaged. To achieve above ground detonation or near impact detonation, remove the grenade's safety clip and safety pin, release the safety lever, and count ONE THOUSAND ONE, ONE THOUSAND TWO, and then throw the grenade. This procedure will expend a sufficient period (about two seconds) of the grenade's four-to five-second time delay. This will cause the grenade to detonate above ground or shortly after impact with the target. Fragmentation and white phosphorous hand grenades will not be detonated in such a manner in training.

### 3-3. PLANS AND PREPARATIONS FOR COMBAT

The basic load of hand grenades is normally established by the theater commander. The basic load is not a fixed quantity; it may be altered as situations dictate. Units will vary their basic load, depending upon the commander's analysis of METT-T.

a. The most important factor in determining the basic load for hand grenades is unit mission. It will influence the type and quantity of hand grenade selected.

b. Other factors used in determining the hand grenade basic load are as follows:

(1) Weight. Each hand grenade weighs close to one pound. Consequently, each grenade that the soldier carries adds another pound to his total load.

(2) Weapons tradeoff. Soldiers cannot carry everything commanders would like to take into battle. The value of various weapons and munitions must be considered by commanders with a view toward determining which will contribute the most to mission accomplishment. For example, tradeoffs may be required between hand grenade types, hand grenades and mines, and hand grenades and mortar ammunition.

(3) Balance. Different types of hand grenades will be required on all missions. Generally, fragmentation and colored-smoke grenades will be required for all missions. Hand grenades selected for a mission should be distributed among several if not all soldiers.

(4) Individual duties. Distribute hand grenades to each soldier that are specific for his job and assigned tasks.

#### 3-4. EMPLOYMENT RULES

The following are rules to remember before employing hand grenades, or when in an area where they are being used.

- o Leaders identify soldiers who should not throw or carry grenades in combat.
- o Know where all friendly soldiers are.
- o Use the buddy team system.
- o Ensure the projected arc of the fragmentation or an offensive hand grenade is clear of obstacles.
- o Evacuate positions into which a fragmentation or offensive hand grenade is thrown, if possible. If this is not feasible, then use the grenade sump.

#### 3-5. OFFENSIVE EMPLOYMENT

Fragmentation and offensive hand grenades are the primary types of grenades used during offensive operations. They provide the violent, destructive, close-in firepower essential for the individual soldier to overcome and kill his enemy. These grenades make individual soldier movement easier by suppressing the enemy and disrupting the continuity of the enemy's defensive fires. Fragmentation hand grenades contribute greatly to destroying the enemy's will to continue the fight. The noise, flash, and concussion generated by fragmentation and offensive grenades have a

severe psychological effect on soldiers. Fragmentation hand grenades help gain the initiative, maintain the momentum of the assault, and rapidly clear the objective of enemy resistance.

a. The critical phase of the attack is the final assault -- that moment when a soldier closes with the enemy to kill him. The individual soldier uses his rifle, hand grenades, and bayonet during the assault. The soldier will first use his rifle, firing controlled, well-aimed shots at known or suspected enemy positions. He does this as part of a buddy team, fire team, and squad. He is controlled and disciplined in his movement and application of fires by using established unit SOPs and battle drills. These battle drills are rehearsed extensively during preparation for combat. As the soldier closes to hand grenade range, he engages the enemy with a combination of rifle fire and hand grenades. Fragmentation grenades will be used to kill and suppress enemy soldiers in the open, in defilades, or in trenches. Movement toward the enemy must be rapid and violent.

b. Hand grenades must be thrown accurately into enemy positions to reduce the chances of friendly hand grenades hitting friendly forces. Movement forward should be done as part of a buddy team. One soldier within the buddy team provides overmatching, direct suppressive fires while the other soldier moves forward. Both soldiers must take advantage of the hand grenade explosion to immediately continue their movement forward. If the enemy is located in an enclosed area, such as a bunker or room (within a building), the offensive grenades may be more appropriate than the fragmentation grenades. This, of course, will depend upon availability and prior mission analysis. Offensive grenades have less of a killing effect on the enemy, but for that same reason, safer to employ in confined spaces. When used, their employment should be immediately followed by violent rifle fire unless capturing enemy personnel is a mission requirement. Remember, an enemy who is only temporarily stunned can still kill you. The shock waves from an offensive grenade also provide better overall interior effect in an enclosed space. Another advantage of the offensive grenade is it covers more of an enclosed space than a fragmentation grenade.

c. In an assault against a dug-in, well-prepared enemy, use hand grenades to clear crew-served weapons first. Once the first defensive belt has been penetrated, use hand grenades in a priority effort to attack command bunkers and communications equipment, and kill enemy leaders within those bunkers.

d. In the assault, the soldier participates as a squad member in clearing trenches, destroying bunkers, and clearing rooms. Unit procedures, which have been rehearsed during preparation for combat, will be employed. The buddy team forms the basis for all fragmentation or offensive grenade employment in the following general situations:

(1) Clearing a trench within a fortified position  
(Figure 3-1).

(a) Before entering the trench, the first clearing team throws hand grenades into the trench.

(b) After the grenades explode, the first clearing team rolls into the trench, landing on their feet and firing their weapons down both directions of the trench.

(c) The first clearing team should hold the entry point.

(d) The teams following the first clearing team should enter at the same position and begin clearing in one direction only (see FM 7-8).

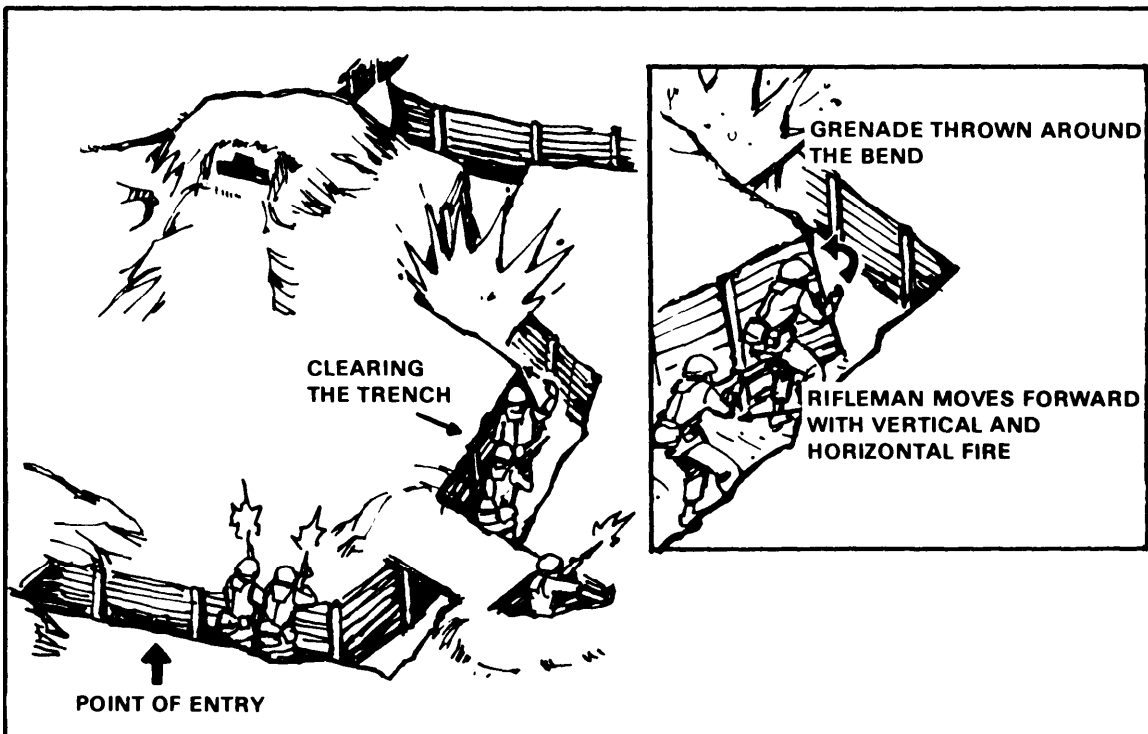

Figure 3-1. Enemy trench assault.

(e) As the lead buddy team moves to the right (left), one soldier is the designated grenadier. He moves along the wall closest to the next bend in the trench. His movement is covered by his buddy who is ready to fire at enemy soldiers advancing toward them. The grenadier holds a grenade at the ready as he moves rapidly down the trench.

(f) At the bend in the trench, the designated grenadier throws a grenade around the bend. After the explosion, the rifleman moves rapidly around the bend and fires rapid bursts horizontally and alternately along the long axis of the trench.

(g) Movement down the trench continues by alternating the designated rifleman and grenadier roles or maintaining the same roles throughout. Fire teams and squads are bounded forward to continue clearing the trenchline.

NOTE: Many of these tasks will be specified by unit SOP. If a three-man clearing team is used, the third member guards the back of the other team members and stands by to provide fire on point targets. See FM 7-70 for actions on the objective.

(2) Clearing a bunker position (Figure 3-2).

(a) Destroying an enemy bunker and killing the enemy soldiers inside requires violence and speed of execution, plus synchronization of effort at the buddy team and squad level in order to succeed.

(b) A two-man buddy team assaults a single bunker using a combination of grenades and rifle fire. One member of the buddy team provides overwatching suppressive fire while the other member moves rapidly toward the bunker, using a combination of individual movement techniques. He uses the best available covered route to move toward the bunker.

(c) As he approaches to within 75 meters of the bunker, he can use white smoke thrown on line with the bunker (and as close to the enemy's firing port as possible) to help conceal his movement for the remaining distance.

(d) Once the grenadier member of the buddy team is at the side of the bunker, he cooks off and throws fragmentation or offensive grenades into the firing port

of the bunker. Once thrown, he rolls away from the bunker and faces to the rear of the bunker prepared to engage escaping enemy soldiers with his rifle. After the grenade detonates, he enters the position from the rear to kill or capture remaining enemy soldiers.

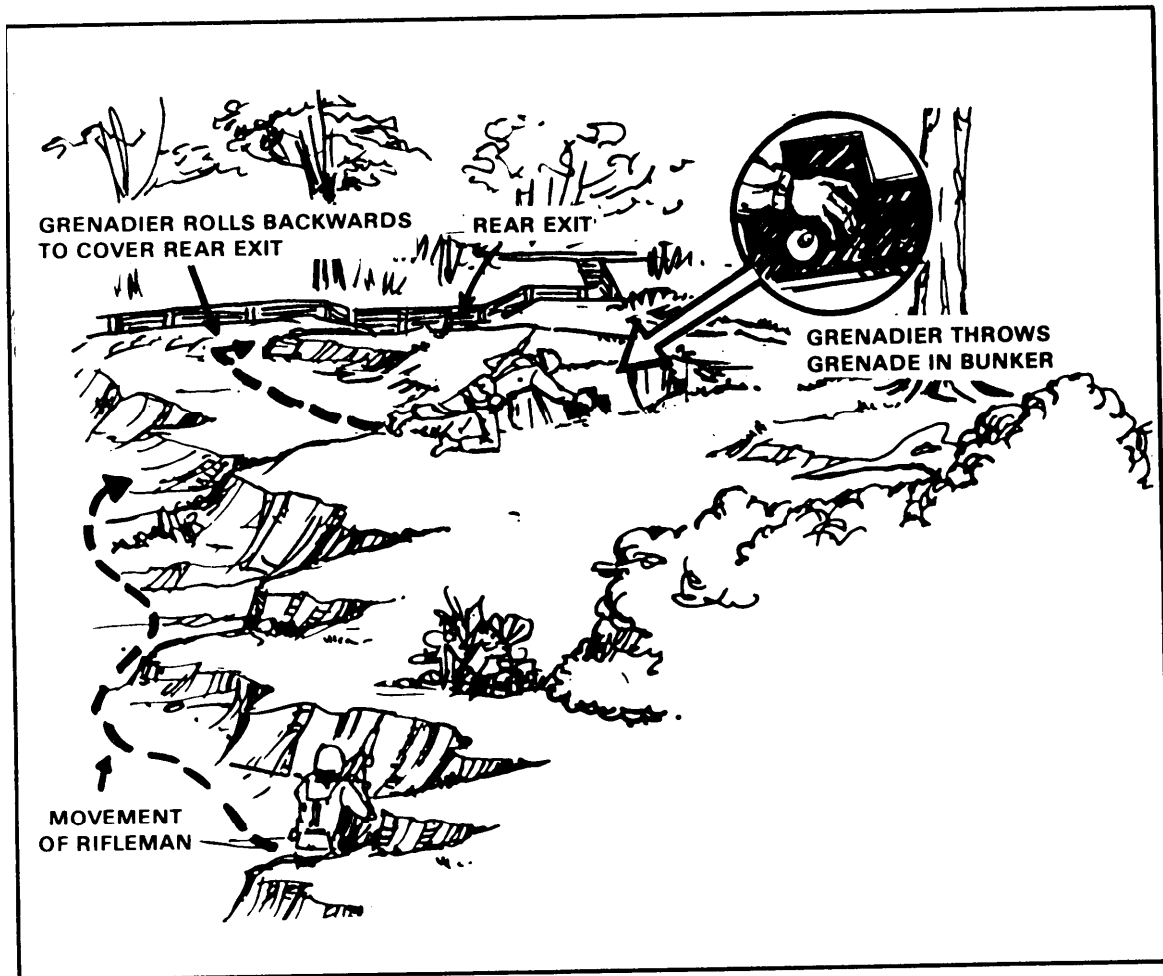

Figure 3-2. Enemy bunker assault.

(3) Clearing a room in a built-up area.

(a) An assault party (two-man minimum) is assigned to clear each room. They enter a room through the doorway, knocking the door down if necessary. Before entering the room, they forcefully throw a grenade into the room. After detonations, one man quickly enters and moves out of the doorway to one side or the other, sprays the room with short bursts of automatic fire, and takes up a position where he can observe the entire room. The assault party should not be silhouetted in the doorway.

(b) At this time, the assault party must be prepared to react instinctively to any situation in the room. The second man shouts COMING IN, enters, and conducts a systematic search of the room, avoiding silhouetting himself in windows. In like manner, a soldier leaving a room through an entrance covered by another soldier would shout COMING OUT. It is important that soldiers are aware of each other's location at all times.

(4) Using hand grenades during raids.

(a) The raid, as a type of offensive operation, is characterized by a heavy use of fragmentation and offensive grenades, although it may also require other types of grenades.

(b) For example, if the mission is to secure prisoners, the employment of offensive grenades is appropriate. If the destruction of vehicles, weapons, or special equipment is required, incendiary hand grenades are needed. Colored smoke grenades always have application for marking pickup zones and identifying the location of friendly forces.

(5) Reacting to enemy ambushes.

(a) Reaction to an enemy near ambush requires an immediate, rapid, and violent response. The longer friendly forces remain in the ambush kill zone, the greater the probability of friendly force destruction. FM 7-70 and ARTEP 7-8 Drill describe friendly force reactions. Using a combination of fragmentation hand grenades to kill the enemy and white smoke grenades to obscure the enemy's sight and rifle fire, the soldiers within a squad assault the enemy force.

(b) Drill squad members to throw both grenades -- fragmentation first, then smoke.

### 3-6. DEFENSIVE EMPLOYMENT

Hand grenades are used in defensive operations during the final phase of the close-in battle.

a. The primary hand grenade in all defensive operations is the fragmentation grenade. It is used in conjunction with other weapons and man-made or natural obstacles to destroy the remnants of the attacking enemy force that have succeeded in penetrating the more distant barriers and final protection fires.



b. The fragmentation hand grenade further disrupts the continuity of the enemy attack, demoralizes the enemy soldier, and forces the enemy into areas covered by direct fire weapons, such as rifle and machine gun fire and Claymore mines. The use of fragmentation hand grenades at the critical moment in the assault for a dismounted enemy force is the final blow in taking the initiative away from him.

(1) From individual fighting positions (Figure 3-3). Fragmentation hand grenades are used from defensive fighting positions primarily to cover close-in dead space approaches on the friendly side of the protective wire and in front of a squad's position. They should be used in conjunction with ground flares positioned along the protective wire. Enemy soldiers stopped at the protective wire should be engaged first with Claymore mines. If time permits during the preparation of the defensive position, soldiers should identify dead space in their sector, especially that dead space that may intersect the protective wire, and move toward friendly fighting positions. This potential avenue of approach through the protective wire should be marked with a reference to identify it as a primary hand grenade target. The following rules apply when employing fragmentation hand grenades from fighting positions.

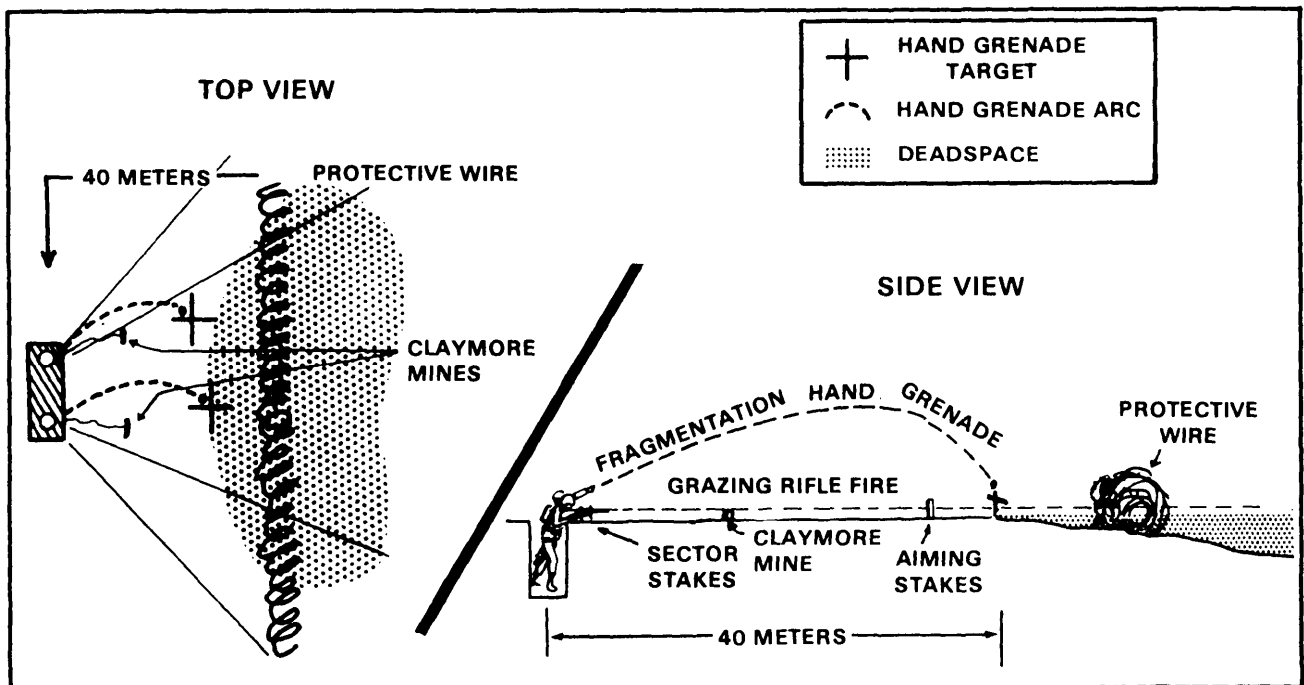

Figure 3-3. Defense from individual fighting positions.

(a) Clear overhead obstructions, which may interfere with the path of the thrown grenade. Do this at the same time direct fire fields of fire are cleared.

(b) Rehearse grenade employment; know where your primary target is.

(c) Keep 50 percent of your fragmentation grenades at the ready in your fighting position, leaving the remaining fragmentation grenades on your load-carrying equipment.

(d) Rehearse actions to be taken if an enemy grenade lands in your fighting position.

**WARNING: SOVIET GRENADES USE FUZES WITH ONLY A 3- TO 4-SECOND DELAY, WHICH MEANS YOU HAVE VERY LITTLE TIME TO REACT. THE PREFERRED COURSE OF ACTION IF AN ENEMY GRENADE LANDS IN YOUR POSITION OR NEAR YOU IS TO IMMEDIATELY ROLL OUT OF YOUR FIGHTING POSITION OR THROW YOURSELF FLAT ON THE GROUND**

(e) Employ fragmentation hand grenades against enemy soldiers located in defilade positions as a first priority. This minimizes the danger to friendly soldiers and helps cover terrain not covered by direct fire weapons. Use your rifle to kill enemy soldiers not in defilade positions.

(f) Reconnoiter your alternate and supplementary positions and determine your priority fragmentation hand grenade target.

(g) Redistribute hand grenades after each enemy engagement.

(2) Against enemy armored and tracked vehicles (Figure 3-4). On occasion, friendly dismounted soldiers may come in close contact with enemy armored formations. Dismounted infantry should first use antitank missiles and rockets to defeat enemy armor and motorized infantry. Satchel charges, as described in FM 5-25, can also be used to defeat enemy armor. If these are not available, it is still possible to destroy, immobilize, or render inoperative the vehicle or system, and or to kill the crew inside the vehicle. In either case, the soldier must approach the armored vehicle to kill it or the

crew with hand grenades. Some characteristics and vulnerabilities of Soviet armor must be understood in order to kill or disable the enemy armored vehicle or its crew. Vulnerabilities common to most Threat vehicles are the fuel cells, ammunition storage areas, and power trains. Diagrams highlighting these areas on selected Threat vehicles are shown in Figure 3-5.

(a) Turret rotation. The turrets of Soviet tanks rotate much slower than those on US and NATO tanks. It takes more than 21 seconds for a Soviet tank to rotate its turret through a full 360 degrees. The M1 Abrams Tank and M2, Bradley Fighting Vehicle can rotate their turrets a full 360 degrees in 6 seconds. This means a soldier can completely run around a Soviet tank before the turret can be traversed from over the front deck to the rear deck.

(b) Visual dead space. From the Soviet tank gunner's station, nothing within 30 feet at ground level can be seen through the frontal 180 degrees of turret rotation. If the turret is oriented over the rear 180 degrees (rear deck), the dead space increases to 50 feet. This means soldiers in fighting positions cannot be seen by Soviet tank gunners when they are within these distances to the tank.

(c) Fire extinguisher system. A fire extinguisher system can be triggered manually or automatically by one of eight heat sensors. However, the fire extinguisher's ethylene bromide gas creates a poisonous vapor when exposed to flames. If the extinguisher discharges, the crew may have to bail out. Any weapon that can trigger a fire and the fire extinguisher system can possibly knock out a Soviet tank.

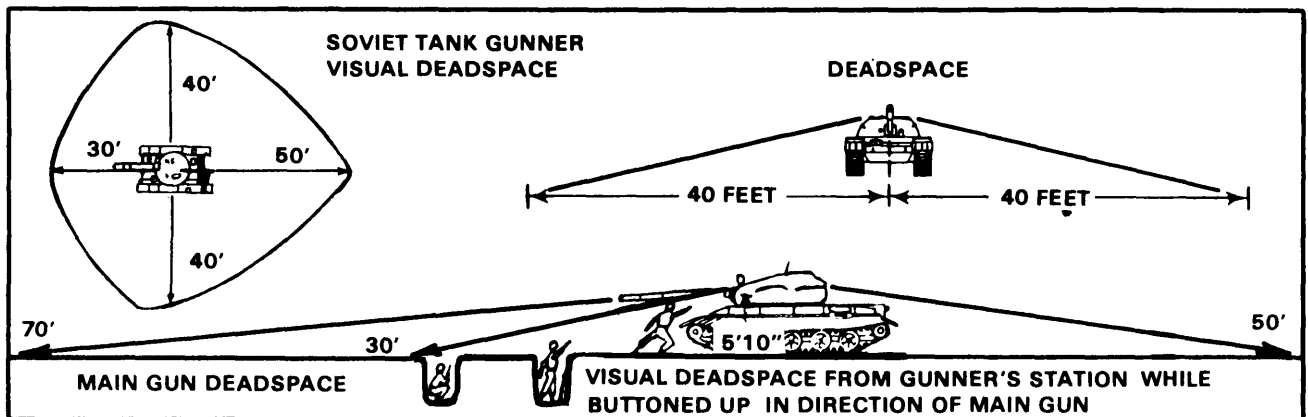

Figure 3-4. Attack of an enemy vehicle.

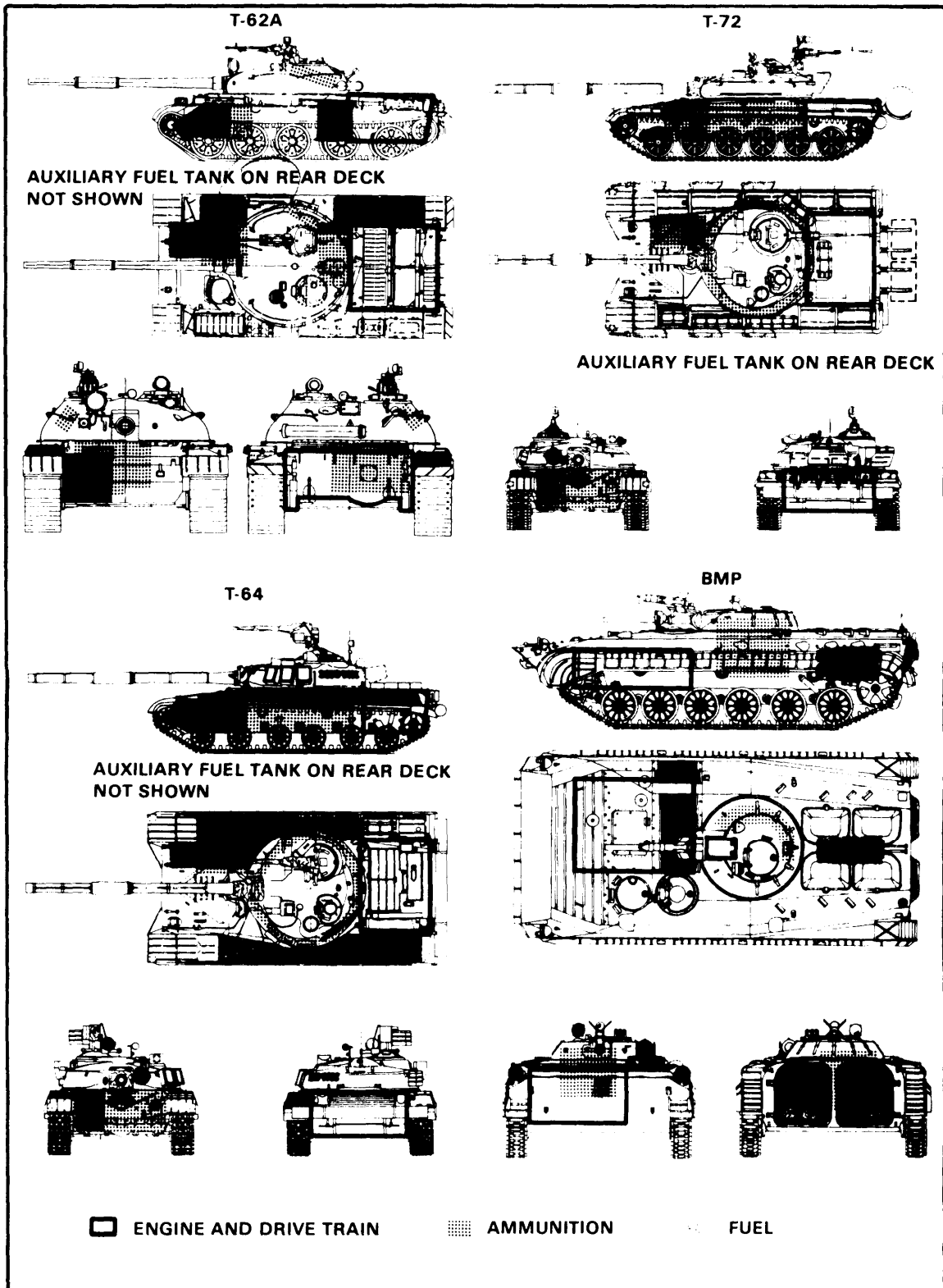

Figure 3-5. Enemy vehicle vulnerabilities.

(d) BMP visual dead space. The BMP has nine vision blocks for the eight infantrymen in the rear of the vehicle. Eight of these vision blocks (four of each side) correspond to the firing ports for the squad's weapons. These vision blocks are oriented at a 45-degree angle toward the vehicle's direction of movement. The soldier at the left rear of the vehicle mans either the left rear vision block or the last vision block and firing port on the left side. If the flank firing port is being manned, the vehicle is vulnerable to an approach from the rear. Dismounted soldiers should attempt to destroy or disable enemy armor vehicles with hand grenades only as a last resort. When employing hand grenades for the purpose, the following procedures are recommended.

- o Remain in a covered fighting position until the vehicle closes to within its visual dead space. Approach the vehicle from the rear, moving aggressively.
- o Place an incendiary grenade over the engine compartment.
- o Attempt to drop a fragmentation grenade into an open hatch if incendiary grenades are not available.
- o Immediately return to cover.
- o Shoot escaping crewmen as they exit the vehicle if it is not disabled by a catastrophic, secondary explosion.

### 3-7. RETROGRADE OPERATIONS EMPLOYMENT

Most of the employment considerations applicable to the use of hand grenades in the defense are equally applicable to retrograde operations. If there is a special application or consideration for hand grenade use during retrograde operations, it would probably be for the creation of obstacles, marking friendly force locations, and breaking contact.

- a. Obstacles. Incendiary grenades can be used when terrain conditions permit initiating fires in specific areas to impede and disrupt enemy movement.
- b. Marking Locations. Colored smoke hand grenades can be used to mark friendly force positions and identify friendly forces.

c. Breaking Contact. During retrograde operations, some elements of the friendly force frequently become decisively engaged. Fragmentation, white smoke, white phosphorous, and CS grenades can all be used for breaking contact and regaining flexibility of maneuver. Use of hand grenades in volley fire immediately following the employment of white smoke is especially effective. The smoke obscures enemy observation of friendly force movement from covered positions, and fragmentation grenade employment forces them to cover.

### 3-8. REAR AREA OPERATIONS EMPLOYMENT

AirLand Battle doctrine recognizes that the nature of a future war poses a significant threat to rear areas. These threats range from large operational maneuver groups to highly trained, special operating forces and even terrorists. All US soldiers in combat, CS, and CSS units must be prepared to fight using the M16A2 rifle, the 9-mm pistol, the AT4 antitank rocket, the Claymore antipersonnel mine, and the fragmentation grenade. At every squad and section throughout the corps battle area, individual US soldiers must react to every action by aggressive, violent employment of grenades and individual weapons. There is no safe zone on the battlefield.

a. Special Considerations. Two features of rear area operations provide for unique considerations insofar as hand grenade employment is concerned. In certain areas of the world, the US Army and its allies must anticipate a large number of civilian refugees moving into and through the rear area. The situation will be further confused by the large members of CS and CSS units operating throughout the rear area. These factors dictate the following in regard to hand grenade employment in the rear areas.

(1) Offensive grenades. Grenades are thrown by individual soldiers at enemy soldiers in all threat situations. US forces should consider using the offensive grenade, especially in those situations where noncombatants and support troops may be intermingled with threat forces.

(2) Riot control grenades. It is not unreasonable to expect enemy SPETNAZ, special agent provocateurs, and fifth columnists to attempt to incite riots in our rear areas, especially if the conflict begins to stalemate and does not result in a rapid victory for either side. Forces in the rear area must quell these riots as rapidly as possible while minimizing potential damage to the

lives and property of noncombatants. Riot control grenades, which are usually associated with peacetime law and order functions, also have relevancy in maintaining control of the rear area.

b. Base Cluster Defense. Base cluster commanders must organize the defense of their positions in much the same manner as tactical commanders in the MBA. Accordingly, the employment of hand grenades from defensive positions surrounding the base cluster is based on the same considerations as hand grenade employment by combat units in the MBA.

### 3-9. USE UNDER ADVERSE CONDITIONS

While hand grenade procedures do not change when employed under adverse conditions, special cautions must be considered.

a. MOPP 4. Exercise additional caution when employing hand grenades while in MOPP gear. Arming and throwing procedures must be executed slowly and deliberately. It is recommended that the thrower observe each arming action (removal of safety clip and safety pin). Concentrate on the grip. Wearing gloves will inhibit the thrower's feel and could decrease his throwing ability.

b. Night. Throwers must have clear fields of fire and no overhead obstructions. Depth perception is generally impaired under limited visibility conditions.

## CHAPTER 4

## TRAINING PROGRAM

The intended outcome of all hand grenade training programs is to produce soldiers that are proficient in the use of hand grenades in any tactical situation. The training program should incorporate safe handling and throwing practices, which will reduce injuries not only in peacetime, but in combat as well. Initially, training programs will require extensive direct supervision; but, as soldier proficiency increases, the amount of supervision required decreases.

## 4-1. OBJECTIVES

The hand grenade training program should progress using the crawl-walk-run methodology. The program progresses from fundamental to advanced training, culminating with the integration of hand grenades into situational and field training exercise. Once soldiers reach a high proficiency level, a sustainment program should be implemented to maintain this level. The following progressive training program objectives are offered for use or modification:

- o Instruction on visual identification of hand grenades.
- o Instruction on capabilities of hand grenades.
- o Technical instruction on grenade function.
- o Instruction and practical exercises on fundamentals of gripping, throwing, and throwing positions.
- o Practical exercises using targets of different types at varied ranges that stress distance and accuracy.
- o Advance training courses listed in this chapter, except for the target engagements at varied ranges, accuracy, buddy teams, movement techniques, and weapon integration.

## 4-2. TRAINING COURSES

The training courses listed in this chapter, except for the standard Army hand grenade qualification course, are offered as models to assist units in meeting their training objectives. These courses may be modified to support the unit METL, terrain, and commander's intent.

- a. Distance and Accuracy.



(1) Purpose. The distance and accuracy course is the initial practical exercise soldiers should perform. It is designed to develop the soldier's proficiency in grenade throwing and reinforce proper throwing habits. To develop good safety habits, supervisors must ensure proper throwing techniques are used by the soldiers.

(2) Conduct of training. The soldier should receive a course orientation, explanation, and demonstration. This must include clarification of the tasks, conditions, and standards for the course, followed by a demonstration that meets the stated standard. During initial hand grenade throwing, soldier should be allowed to observe the strike of the grenade. This feedback allows the soldier to gain an appreciation for the weight of the grenade and the amount of force required to accurately throw the grenade. Proper procedures for seeking cover after throwing a grenade should be stressed after the soldier acquires throwing accuracy. The following is a generic task, condition, and standard to assist units.

TASK: Engage a variety of targets at varying ranges up to 40 meters.

CONDITION: Given 12 practice grenades, individual equipment, and a four-station course with a variety of targets at distances of 20, 30, and 40 meters.

STANDARD: The soldier must successfully engage targets at each station with two out of three grenades, using the prone to kneeling or prone to standing and prone throwing positions. A target is successfully engaged when the grenade detonates within 5 meters of the target.

(3) Course (Figure 4-1). A recommended four-station target course by target type and distance is --

- o A fighting position 30 meters from the throwing line.
- o A trench target 40 meters from the throwing line.
- o A fortified mortar position 20 meters from the throwing line.
- o Soldiers in open, during assault at 20 meters from throwing line.

The four stations may be combined if the terrain does not allow four stations.

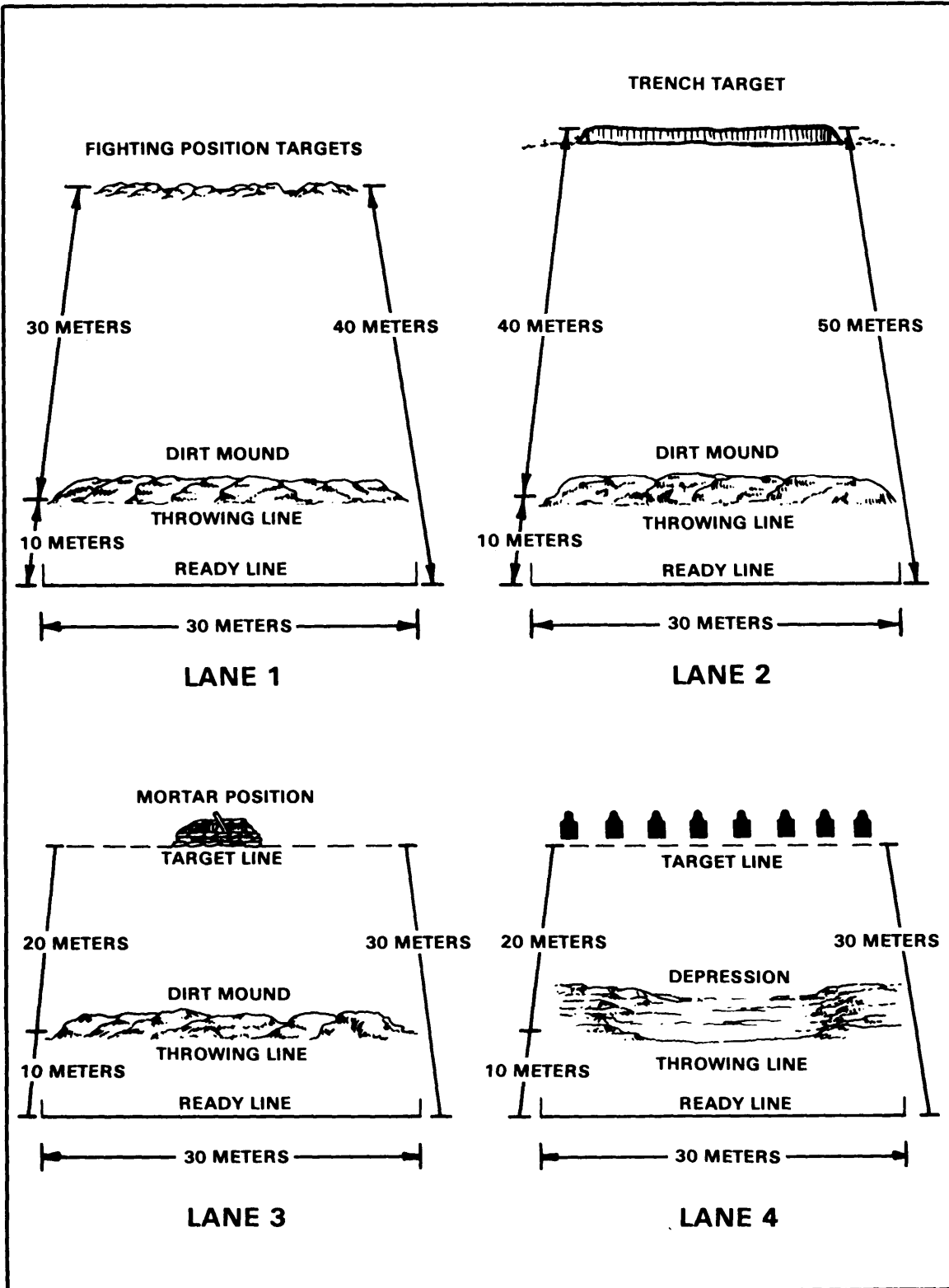

Figure 4-1. Distance and accuracy course.

NOTE: Soldiers throw three grenades at each station. Two of the three grenades must be within 5 meters of the target. If the soldier does not meet the standard, additional training is required until he does.

NOTE: The number of practice throws a soldier needs depends upon his ability to meet the standard. Each soldier is evaluated individually.

b. Practice Training Pit.

(1) Purpose. The practice pit is where soldiers prepare to throw live fragmentation grenades. Training here introduces the soldier to the throwing commands and provides additional throwing practice.

(2) Conduct of training. Soldiers are oriented to the practice training pit and given an explanation of the commands that will be used during actual throwing. Soldiers will then practice the actual procedures used during live pit training. The instructor must enforce correct throwing and safety procedures. Improper techniques or bad habits, which a soldier could carry over to live pit training, cannot be tolerated. The following is a generic task, condition, and standard to assist units.

TASK: Successfully throw practice hand grenade from the practice pit and follow all commands from the NCOIC.

CONDITION: Given individual equipment, to include flak vest, practice hand grenades, a practice pit that replicates a live pit, and an orientation and safety briefing.

STANDARD: Soldier must safely carry, arm, and throw two practice hand grenades from the practice pit while following the tower commands and safety NCO's instructions. Soldiers must not move from the cover of the pit until the command CLEAR or ALL CLEAR is given.

NOTE: The physical layout of the practice pit should replicate the live throw pit.

c. Live Pit.

(1) Purpose. The live pit gives soldiers the opportunity to experience the sensations of throwing a live fragmentation grenade. This instills confidence in the soldiers' ability to throw the hand grenade and its lethality.

(2) Conduct of training. The procedures and techniques of conducting live hand grenade range operations depend upon available facilities and their regulations. Each facility has its own safety features and training qualities, making it difficult to standardize the operating procedures. The following guidelines are provided to assist in the conduct of live hand grenade training:

- o Soldiers must have practice pit training before training at the live/throwing pit (Figure 4-2).
- o Soldiers must receive a safety briefing first.
- o Throughout hand grenade training and particularly at a live pit, instructors must instill confidence in the soldiers--not apprehension. Hand grenades are inherently safe when used properly.
- o Soldiers throwing a live hand grenade must have a target. This makes sense tactically and provides a safer training environment. (Consult local range regulations for restrictions.)
- o If facilities permit (observation windows available) , allow soldiers to observe live/throwing pit procedures before they throw live hand grenades. (See Figure 4-3 for suggested live pit layout.)
- o Soldiers must attach hand grenades to ammunition pouches and carry them to the throwing pits.
- o Soldiers must wear flak vests, helmets, and, if available, eye armor.

NOTE: Instructors must check soldiers by using the live hand grenade range operation checklist in Appendix B.

The following task, condition, and standard are offered for use.

TASK: Engage targets with a live fragmentation grenade.

CONDITION: Given individual equipment, to include helmet, LCE, and flak vest, a facility for live hand grenade throwing, and live fragmentation hand grenades attached to the ammunition pouch.

STANDARD: Soldier must safely arm and throw at least two live fragmentation hand grenades. Soldier must comply with all fire commands and instructions.

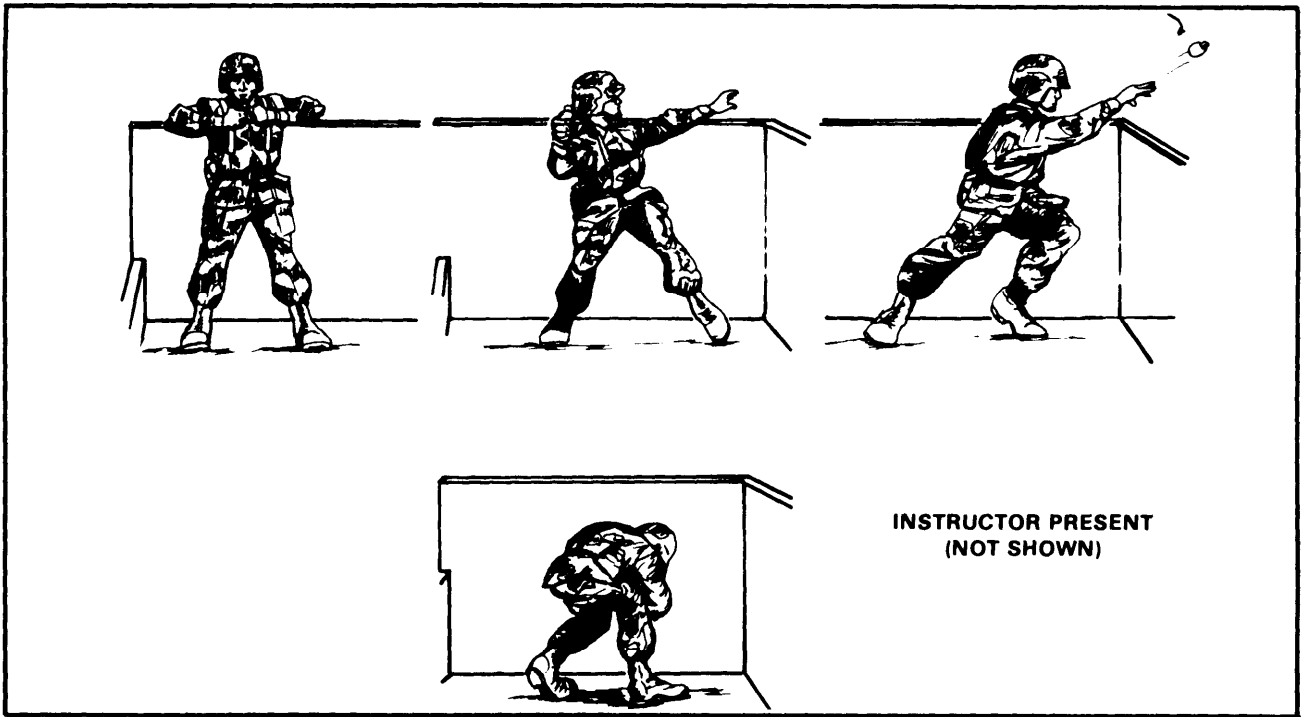

Figure 4-2. Live/throwing pit.

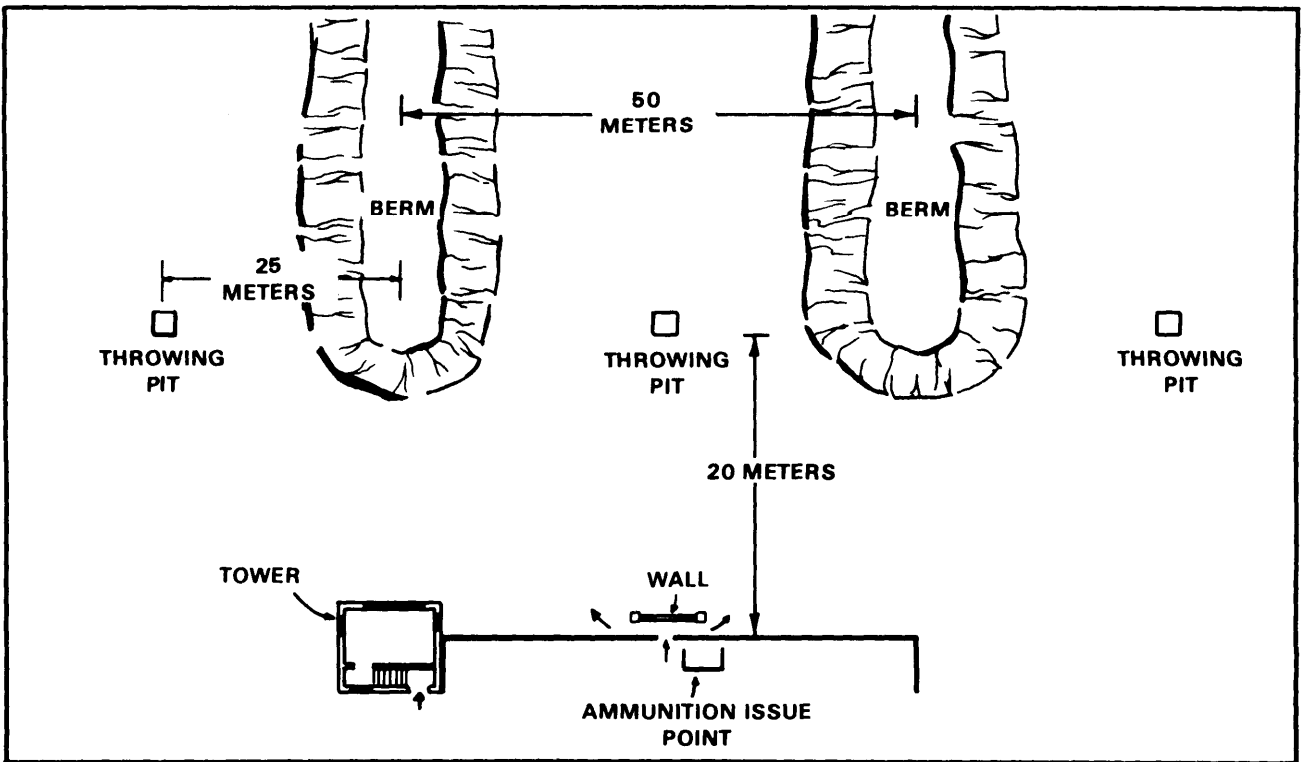

Figure 4-3. Suggested physical live pit layout.

d. Hand Grenade Qualification Course.

(1) Purpose. The qualification course measures and evaluates the soldier's ability to engage a variety of targets with hand grenades using proper throwing techniques.

(2) Conduct of training. The qualification course should not be attempted until after training on the distance and accuracy course. This applies especially to units whose soldiers have not had any hand grenade training. The qualification course allows soldiers to use fuzed, practice hand grenades to engage targets in natural terrain under simulated combat conditions. An added incentive for soldiers to perform well is the award of a hand grenade qualification bar to be worn on his marksmanship medal.

(3) The actual course. The hand grenade qualification course is standardized throughout the US Army. It consists of seven stations with one evaluator per station. The course is conducted in two-man fighting position, ated individually. The stations and their requirements are as follows:

- o Station 1. Engage a group of F-type silhouette targets in the open from a two-man fighting position. The targets will be located 35 meters (25 meters for female soldiers) to the front of the fighting position, simulating enemy movement through and beyond the squad's protective wire.
- o Station 2. Engage a bunker using available cover and concealment. The bunker will have only one firing port oriented toward the direction of the buddy team's movement and a rear exit.
- o Station 3. Engage a fortified 82-mm mortar position from 20 meters.
- o Station 4. Engage a group of enemy targets behind cover 20 meters distant.
- o Station 5. Clear an entry point to a trench line 25 meters distant.
- o Station 6. Engage troops in a halted, open type wheeled vehicle, 25 meters distant.

o Station 7. Identify hand grenades. soldiers must be able to identify grenades by shape, color, markings and capabilities. For a suggested identification station, refer to Figure 4-4. While no two hand grenade qualification courses will be physically the same, the standards must be consistent. The DA Form 3517-R (Hand Grenade Qualification scorecard) at Figures 4-5 (front) and 4-6 (back) establishes the task, condition, standard, and scoring procedure for the qualification course. DA Form 3517-R will be locally reproduced on 8 1/2 - by 11 inch paper and is located at the back of this regulation. Qualification must be awarded only to those soldiers who meet these standards. The evaluator at each station will determine scoring in accordance with the standard scorecard. Figure 4-7 shows a sample physical layout.

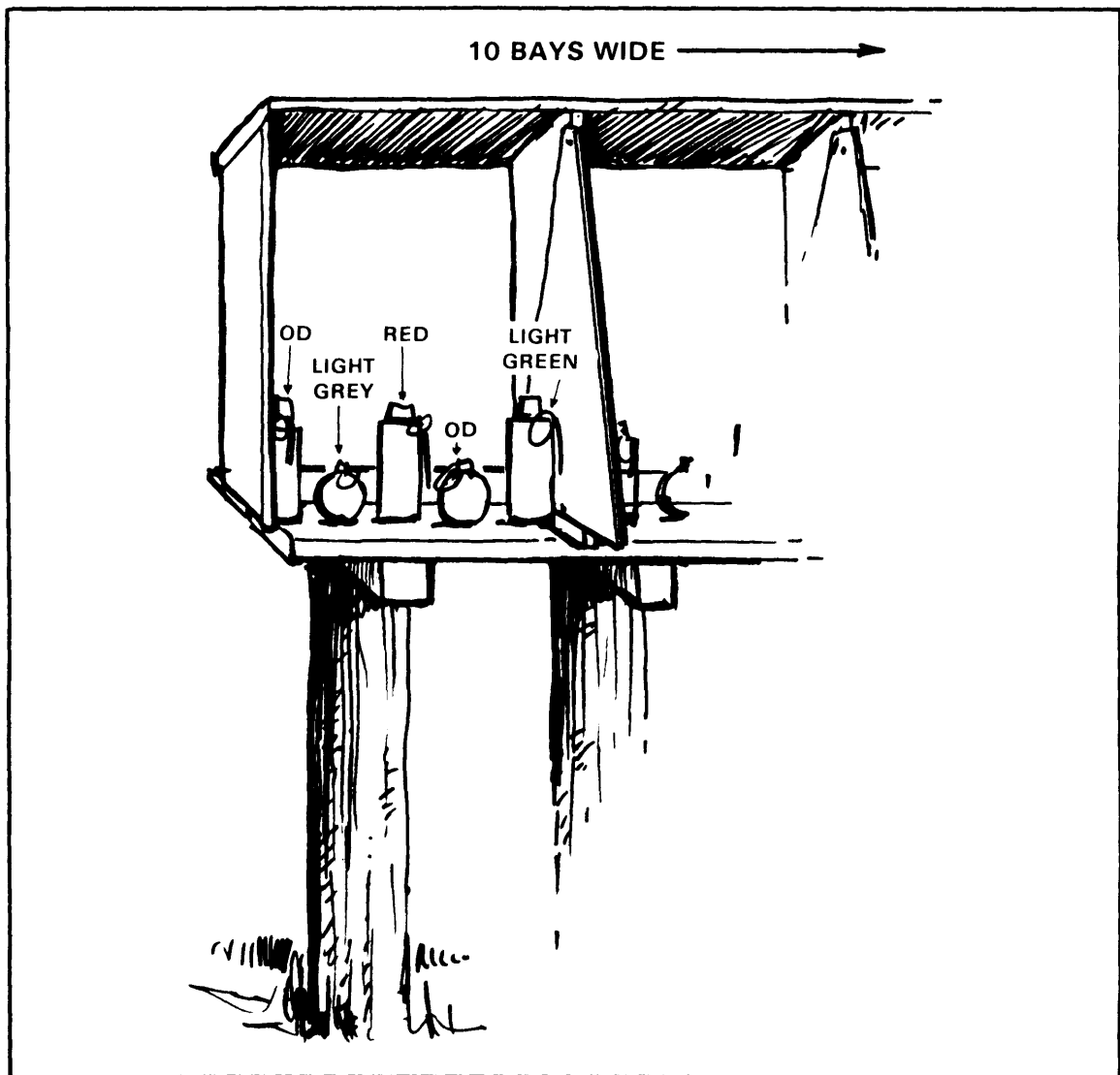

Figure 4-4. Suggested identification station.

# HAND GRENADE QUALIFICATION SCORECARD

For use of this form, see FM 23 30, the proponent agency is TRADOC

**NOTE:** In Addition to the Requirements on this Scorecard, the Soldier Must Throw Two Live Fragmentation Grenades to Qualify.

A DATE LIVE GRENADES WERE THROWN <i>17 SEPT. 88</i>		B INITIALS <i>ERJ</i>		
C NAME (Last, First, Middle Initial) <i>MOORE, GARY</i>		D DATE <i>17 SEPT. 88</i>		
E GRADE <i>E-7</i>	F SSAN <i>256-88-5011</i>	G UNIT <i>D 2/29 INF.</i>		

H STATION	I TYPE TARGET	J GO	K NO-GO	L SCORER INITIALS
1	Engage Enemy from Fighting Positions at 35 Meters (25 Meters - Females)	✓		<i>S.T.</i>
2	Engage Bunker	✓		<i>T.F.</i>
3	Engage 82-MM Mortar Position at 20 Meters	✓		<i>L.J.</i>
4	Engage Enemy Behind Cover at 20 Meters	✓		<i>JW</i>
5	Engage Trench at 25 Meters	✓		<i>TW</i>
6	Engage Wheeled Vehicle at 25 Meters		✓	<i>EP</i>
7	Identify Hand Grenades	✓		<i>DF</i>

### M. QUALIFICATION STANDARD

		CHECK
PASSED 7	EXPERT	
PASSED 6	FIRST CLASS	✓
PASSED 5	SECOND CLASS	
PASSED 4 OR LESS	UNQUALIFIED	

N SIGNATURE OF SCORER/OIC

*ER Zimmerman*

DA FORM 3517-R, NOV 88

DA FORM 3517-R, JUL 69 IS OBSOLETE

Figure 4-5. Scorecard, front.



STATION 1 Engage Enemy From Fighting Position at a Range of 35 Meters (25 Meters for Females) (Standing)			STATION 6 Engage Vehicle at 25 Meters (Kneeling)		
PERFORMANCE MEASURES	GO	NO-GO	PERFORMANCE MEASURES	GO	NO-GO
A. Detonated at Least One Grenade Within 5 Meters of the Center of Target	✓		A. Detonated Within 1 Meter of Vehicle or Within 5 Meters of Dismounting Troops.	✓	
B. Kept Exposure Time Under 3 Seconds.	✓		B. Kept Exposure Time Under 3 Seconds.	✓	
C. Returned to Covered Position After Each Throw	✓		C. Returned to Covered Position After Each Throw.	✓	
D. Used Proper Grip.	✓		D. Used Proper Grip.		✓
E. Used Proper Throwing Techniques.	✓		E. Used Proper Throwing Techniques.	✓	
F. Completed Performance Measures 1A Through 1E Within 15 Seconds.	✓		F. Completed Performance Measures 6A Through 6E Within 15 Seconds.	✓	
STATION 2 Engage Bunker			STATION 7 Identify Hand Grenades		
A. Approached from Blind Side.	✓		A. Selected Fragmentation Grenade to Engage Enemy Soldiers.	✓	
B. Checked for Bunker Opening.	✓		B. Identified M8 Grenade as "White Smoke" or HC Smoke.	✓	
C. Detonated Grenade in Bunker.	✓		C. Identified M18 Grenades as "Colored Smoke" or "Purple (Etc.) Smoke". (If Specific Color is Stated, it Must be the Same as Color on the Training Aid Grenade Used.)	✓	
D. Rolled Away from Bunker.	✓		D. Identified M25A2 Grenade as CS or Riot Control.	✓	
E. Used Proper Grip.	✓		E. Identified M14 Grenades as Incendiary.	✓	
F. Completed Performance Measures 2A Through 2E Within 15 Seconds.	✓				
STATION 3 Engage 82-MM Mortar Position at 20 Meters (Kneeling)			<p><b>NOTE: FOR PERFORMANCE MEASURES 7A THROUGH 7E. IF EXAMINEE CANNOT CORRECTLY STATE NAME OF GRENADE, BUT CAN CORRECTLY IDENTIFY ITS USE, THEN THE EXAMINEE WILL BE SCORED A "GO".</b></p> <p><b>NOTE: EACH PERFORMANCE MEASURE AT EACH SECTION WILL BE GRADED ON A PASS/FAIL STANDARD. A SOLDIER MUST PASS ALL OF THESE STANDARDS TO RECEIVE A "GO" ON THAT STATION.</b></p>		
A. Detonated at Least One Grenade Inside Mortar Position.	✓				
B. Kept Exposure Time Under 3 Seconds.	✓				
C. Returned to Covered Position After Each Throw.	✓				
D. Used Proper Grip.	✓				
E. Used Proper Throwing Techniques.	✓				
F. Completed Performance Measures 3A Through 3E Within 15 Seconds.	✓				
STATION 4 Engage Enemy Behind Cover at 20 Meters (Alternate Prone)					
A. Detonated at Least One Grenade Within 5 Meters of the Center of Target	✓				
B. Kept Exposure Time Under 3 Seconds.	✓				
C. Returned to Covered Position After Each Throw.	✓				
D. Used Proper Grip.	✓				
E. Used Proper Throwing Techniques.	✓				
F. Completed Performance Measures 4A Through 4E Within 15 Seconds.	✓				
STATION 5 Engage Trench at 25 Meters (Kneeling)					
A. Detonated at Least One Grenade Inside Trench.	✓				
B. Kept Exposure Time Under 3 Seconds.	✓				
C. Returned to Covered Position After Each Throw.	✓				
D. Used Proper Grip.	✓				
E. Used Proper Throwing Techniques.	✓				

REVERSE OF DA FORM 3517-R, NOV 88

Figure 4-6. Scorecard, back.

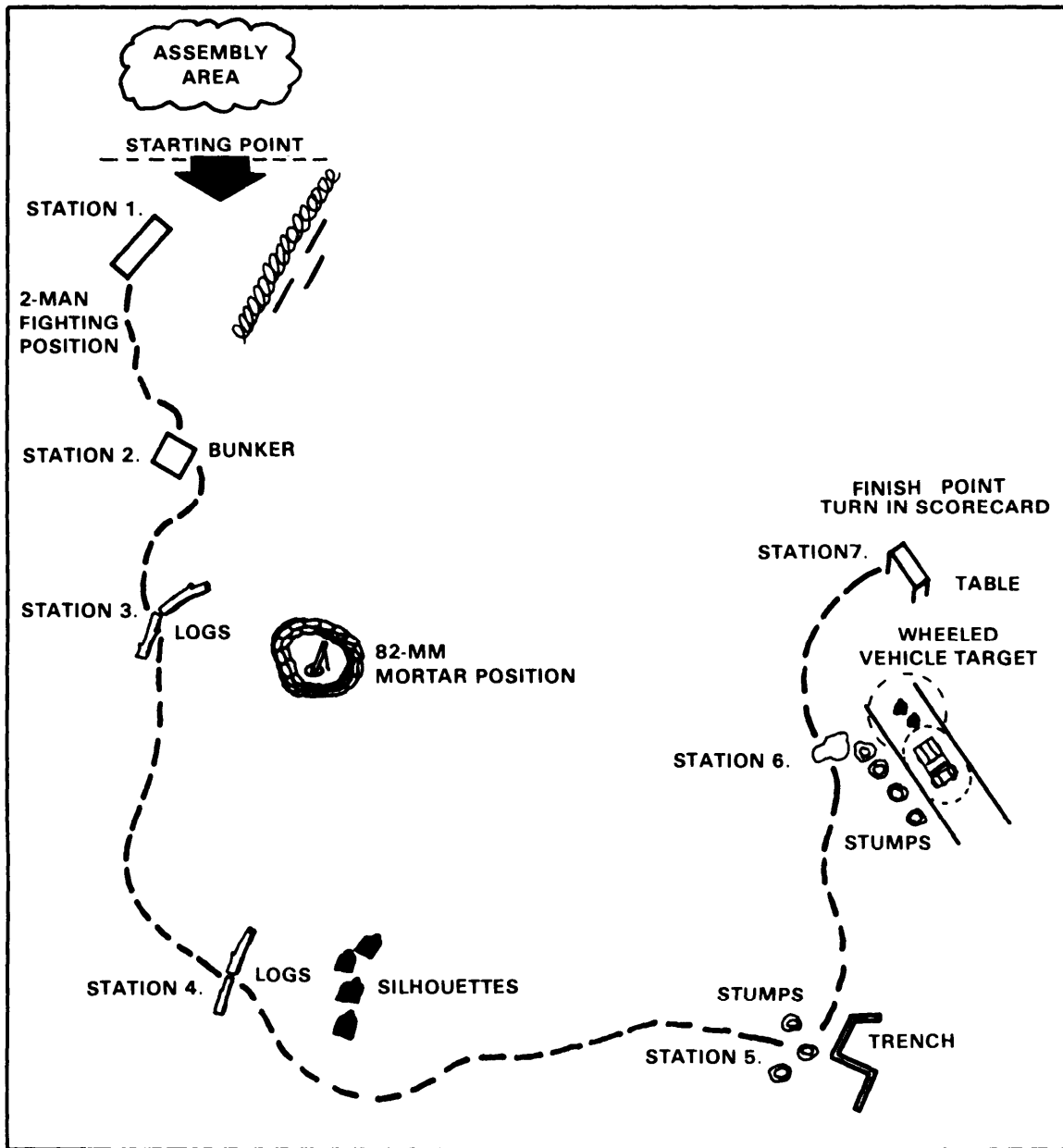

Figure 4-7. Qualification course layout.

e. Hand Grenade Confidence Course.

(1) Purpose. Once the soldier has developed his throwing proficiency and has been introduced to throwing casualty-producing hand grenades, he should be given an opportunity to apply his newly acquired proficiency in a simulated tactical situation requiring the use of grenades. The hand grenade confidence course is designed to accomplish this objective (Figure 4-8).

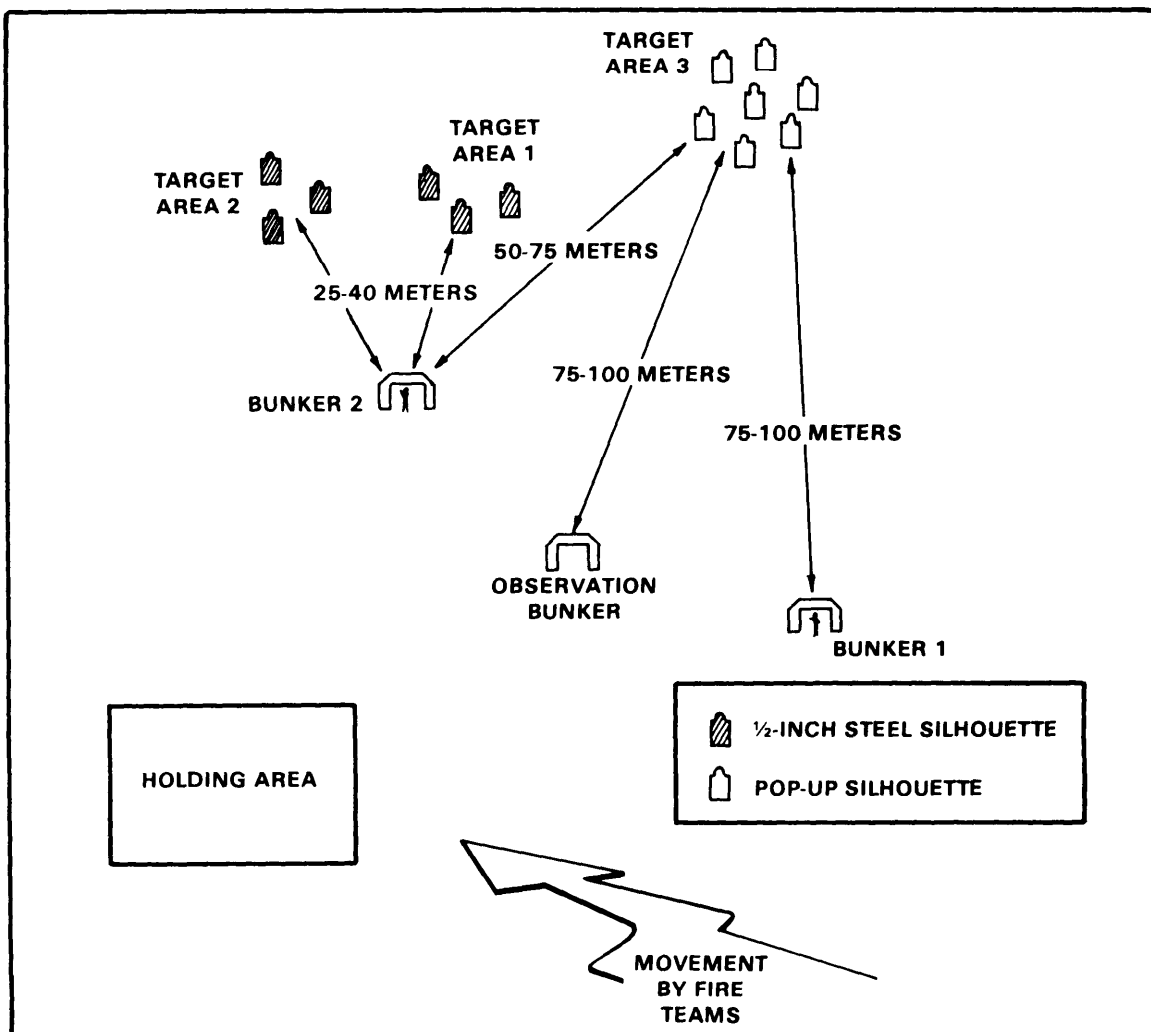

Figure 4-8. Confidence course layout.

(2) Conduct. The hand grenade confidence course has a practice and a live course, each consisting of an assembly area, a final coordination line, an initial holding area, a covering position, a throwing position, and a final holding area.

(a) The course is begun with an orientation period covering the characteristics and functioning of the practice and fragmentation hand grenades, safety considerations governing the conduct of training, and a discussion and demonstration of the conduct of the course for the entire unit being trained.

(b) Following the initial orientation, each squad member is given a number (1-9). Each platoon is moved to a separate assembly area for the practice course

where the OIC of the range presents a tactical situation. Unfuzed practice hand grenades are issued to the platoon for the practice conduct of the course. (All personnel are inspected by the OIC before they negotiate the course to make certain that all grenades are properly secured.)

NOTE: The OIC should determine whether to issue grenades to the soldiers in the holding area or at the throwing bunker, depending upon their experience and proficiency.

(c) The first squad moves in a line formation, ALPHA team on the right, from a tree line that represents the final coordination line of the practice course.

(d) Upon arrival at a mound representing the initial holding area, the squad is taken under fire by a machine gun simulator. The squad leader sends two men from the right side of the line to bunker number one near the objective. One man lays down a base of fire at target area number three. The control NCO directs the number one man on the right to move to bunker number two within hand grenade range of the objective. From bunker number two, the soldier continues to fire his weapon until all far targets are suppressed. He then observes target area number one and engages it with a practice hand grenade. When the grenade is thrown, the safety officer commands ALL DOWN. This command pertains to everyone in the training area. At this time, all personnel get behind protective cover. After the grenade functions (the safety officer counts to seven, which indicates the amount of time personnel must remain behind the protective cover) , the soldier engages target area number two with a second practice hand grenade. When the grenade is thrown, the safety officer commands ALL DOWN.

(e) The soldier who threw the grenades moves by the most direct route back to the final holding area where he is critiqued by the critique NCO. Covering fire is continued from bunker number one. The squad leader then sends a new man to bunker number one where he provides covering fire for the number two man who moves to bunker number two to throw his grenades. After the second grenade functions, the soldier being critiqued by the critique NCO moves directly to the initial holding area.

(f) The above sequence is repeated until all squad personnel have thrown grenades and provided covering fire. The first soldier to throw grenades provides covering fire for the last man to throw.

(g) After the first group has finished the practice course and has been critiqued, it returns to the assembly area and then moves to the live course for the final run with fragmentation grenades. After the first group has completed the practice course, the practice and live courses are run concurrently on separate training areas.

NOTE: In the practice course, blank rifle ammunition and practice grenades are used. Live ammunition and two live grenades are used in the conduct of the live course.

NOTE: Take off blank adapters before issuing live ammunition.

(h) The safety officer on the practice course must carefully observe the actions of soldiers throwing practice grenades. If the safety officer detects any unsafe acts or extreme nervousness on a thrower's part, the thrower will be identified to the critique NCO. The critique NCO will point out the thrower's mistakes and send him back through the practice course. In some instances, it may be necessary to place an individual who has extreme difficulty in properly handling grenades under the control of an assistant instructor for detailed instruction. In no instance will a man be allowed to throw live fragmentation grenades until he has clearly demonstrated his ability to throw practice grenades during the practice conduct of the course.

(3) Safety personnel. The following safety personnel are required for the hand grenade confidence course:

(a) Officer in charge. The OIC or NCOIC, who will be an E7 or above, is responsible for the overall conduct of the problem, presentation of bleacher orientation, and tactical briefing. After issuing the operation order in the assembly area, the safety officer is positioned in the safety bunker where he has the immediate responsibility of supervising hand grenade throwing.

(b) Squad leaders. The squad leaders alternate moving squads to and from the initial holding areas. They are responsible for ensuring that all personnel are behind protective cover in the initial holding area when grenades are being thrown. Squad leaders must check each soldier's grenades before he moves from the initial holding area to bunker number one.

(c) Safety officer. The safety officer is the senior assistant instructor. He will be an E6 or above, or an ES serving in an E6 position. He is positioned in bunker number one where he controls the movement of all personnel both before and after each grenade is thrown; he also controls the soldier furnishing covering fire.

(d) Critique NCO. The critique NCO is positioned in the final holding area. He administers a critique to each thrower immediately after the man arrives from bunker number two. To ensure continuity, the critique NCO will observe the same squad during both the practice and live courses. The critique NCO will brief each member of the squad after both the practice and live courses. He then returns to the practice course to observe another squad.

(4) Training facility. The training facility for the hand grenade confidence course consists of a practice grenade course for throwing the M69 practice grenades and a live grenade course for throwing fragmentation grenades. These two courses are constructed alike and close together in order to allow easy movement from one to the other. The hand grenade confidence course should be conducted concurrently with another 2-hour period of instruction in order to minimize terrain and personnel requirements. Time breakdown for the conduct of training is as follows:

- o Initial orientation: 20 minutes
- o Tactical situation briefing, ammunition issue, and inspection prior to crossing the final coordination line: 10 minutes.
- o Practice run: 35 minutes. (Practice and live runs are run concurrently after the first squad completes the practice run.)

(5) Ammunition. Each soldier needs 40 rounds of blank, 5.56-mm cartridges; 40 rounds of live cartridges; two grenades, M69 unfuzed; and two M67 series, fragmentation hand grenades. For each demonstration, 40 rounds of blank, 5.56-mm cartridges and two practice hand grenades, M69 unfuzed, are required.

(6) Ranges. The range used for the confidence course consists of two separate areas, each consisting of an assembly area, a final coordination line, an initial holding area, a covering position, a throwing position, a final holding area, a safety officer's observation point, and two target areas.

(a) Assembly area. This area is used as a briefing point and an ammunition issue point. It should be a cleared area, sufficiently large to accommodate a 48- to 60-man platoon.

(b) Final coordination line. This line should be a prominent terrain feature, such as a woodline or stream bed, and located between the assembly area and the objective. Ideally, the area between the final coordination line and the objective should slope uphill. This is the last location outside the surface danger zone where personnel may maneuver freely without the need for cover to protect soldiers from fragmentation danger.

(c) Initial holding area. This area should be located 30 to 50 meters forward of the final coordination line. The area should be a mound or a roadside ditch that is long enough to accommodate nine men and high enough to afford protection for a kneeling man.

(d) Covering position. This position should be a mound or parapet 2 meters (5 feet) high and 3 meters (8 feet) wide across its front side. The position should be 5 meters forward of the right flank of the initial holding area.

(e) Throwing position. This position should be a mound or a parapet 1.5 meters high a-rid, 2 meters wide. The position should be located about 15 meters to the left front of the covering position.

(f) Observation point. This is the safety officer's observation point. It should be a pit affording the minimum frontal protection. The position is located 10 meters to the rear of the throwing position.

(g) Final holding area. This area should have characteristics similar to the initial holding area. The position must accommodate a minimum of two kneeling men. It is located 5 meters to the left of the safety officer's observation point.

(h) Targets. There are three separate target areas in each course (practice or live). The target areas on the practice confidence course should clearly be marked "practice targets".

- o Target area one. This is the impact area for the first hand grenade. The target should be a cluster of 1/2-inch steel E silhouette targets located at ranges varying from 25 to 40 meters.

- o Target area two. This is the impact area for the second hand grenade. The target consists of a cluster of ten 1/2-inch steel E silhouettes. This target should be unmarked and located at ranges varying from 25 to 40 meters and 50 meters to the left of target area one.

- o Target area three. This is the target area for M16 fire. The target consists of a cluster of 15 to 20 E pop-up silhouettes located 50 to 100 meters from bunkers one and two.

(i) Training area (general). The training area should be located on slightly sloping terrain. As much natural vegetation as possible should be left on the site.

#### 4-3. COLLECTIVE TRAINING

Two aspects of preparing for combat are training and rehearsals. When training collective tasks or rehearsing a particular combat mission, noncommissioned officers must analyze the collective tasks to be trained and select the individual tasks that support these collective tasks. They must then integrate these individual tasks into the training and rehearsals.

a. Training managers decide which collective tasks they must practice by analyzing the operation outlines contained in the appropriate mission training plan. The operation outlines lay out the collective tasks required to execute a critical wartime mission. Noncommissioned officers find the individual tasks that support collective tasks by referring to the mission-task matrix in the ap-



appropriate platoon mission training plan. They find the correct training standards in the appropriate soldier's manual task. They use the squad and platoon MTP (ARTEP 7-8-MTP) and FMs 7-8 and 7-70 to see how to use the individual tasks to do their collective tasks.

b. As an example, a team leader learns that his platoon is going to practice the ARTEP mission: attack. He analyzes the mission outline for attack and determines which collective tasks his squad may have to do as part of this mission. Several of these tasks require soldiers to engage in close combat.

c. Soldiers must use hand grenades any time they engage the enemy in close combat. Collective tasks that require close combat are: conduct fire and movement, disengage, knock out bunker, clear a trench line, conduct a raid, conduct hasty ambush, conduct point ambush, defend, and clear a building. Drills that require close combat are: react to contact, break contact, and react to ambush. When units train or rehearse these tasks, they should also train and evaluate the use of hand grenades. Once soldiers can safely arm and throw live fragmentation grenades, units should integrate the use of grenades into collective tasks rather than training it as a separate event. Use simulation or live hand grenades, as appropriate, against realistic targets while practicing the collective task. Noncommissioned officers tell soldiers when and how to use the grenades, evaluate their use, correct mistakes, and retrain soldiers as necessary.

#### 4-4. SAMPLE SQUAD SITUATIONAL TRAINING EXERCISE

Present soldiers with tactical situations in an STX requiring hand grenade use in conjunction with other fire team or squad weapons that force soldiers to make sound tactical decisions on hand grenade employment.

a. The STX must be a realistic training event that improves the soldier's hand grenade throwing skill, the use of his individual weapon, and the collective skills of his fire team and squad.

b. There are no firm guidelines for an STX (Figure 4-9). Consider including hand grenade tasks in the tactical scenario that are best suited to the unit's METL. The close combat tasks listed in paragraph 4-3c should also be offered in a unit STX training program. Soldiers should carry practice hand grenades whenever they carry their individual weapon. They should be required to use both to

maximize their individual capabilities. The use of opposing forces enhances training realism. Opposing force objectives for specific tasks can be found in ARTEP 7-8-MTP.

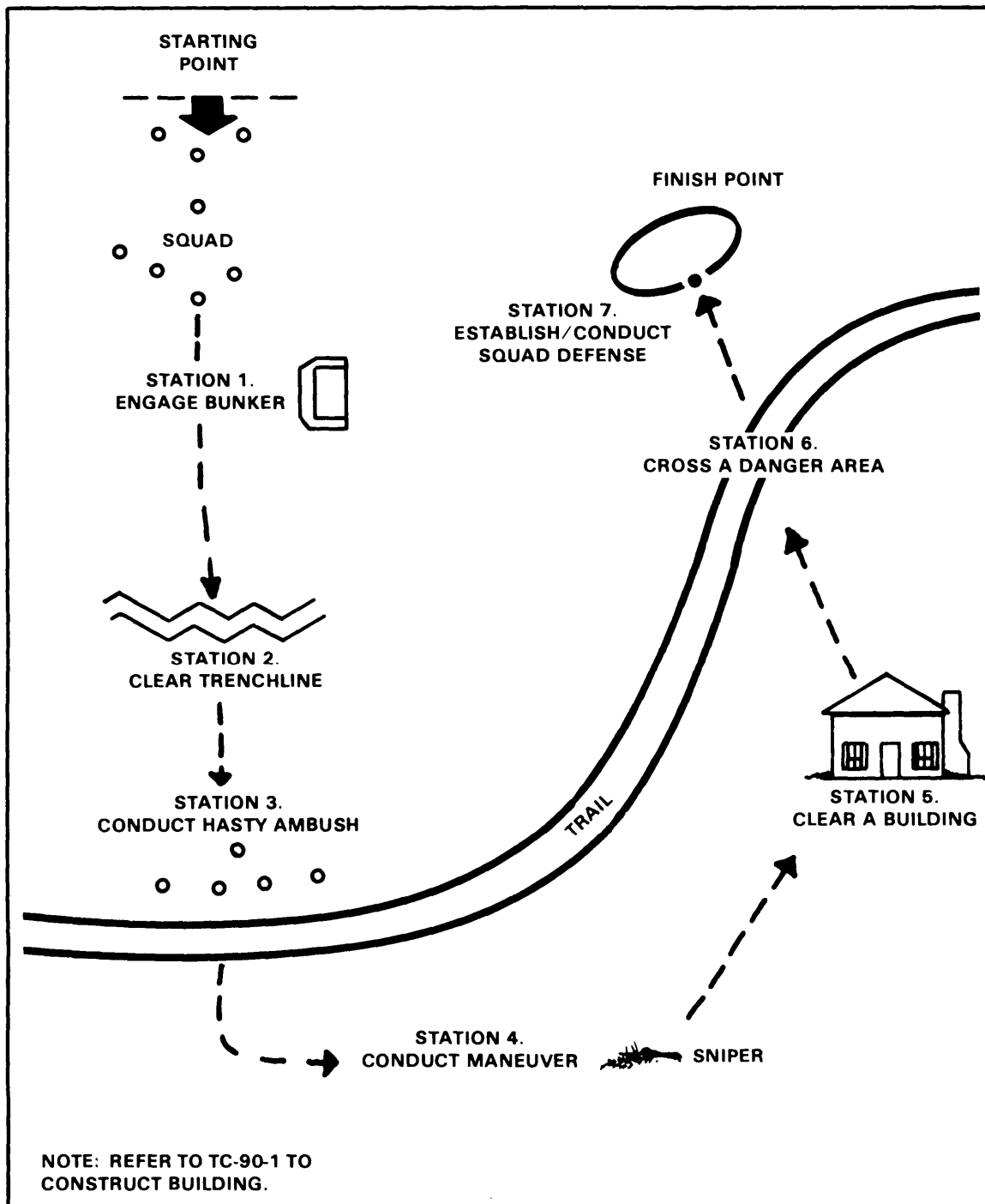

Figure 4-9. Sample squad STX with hand grenade.

## CHAPTER 5

## GROUND PYROTECHNIC SIGNALS

Ground pyrotechnic signals are classified as either hand-held or ground smoke signals. They are used for signaling and illuminating missions.

## 5-1. CHARACTERISTICS

Ground pyrotechnic signals rise to a height of 180 to 250 meters before functioning, unlike the old rifle smoke grenades that functioned either on impact or shortly after firing.

a. Hand-held Signals. These signals are issued in their own launching mechanism and are designed to reach a minimum height of 200 meters. This group of signals includes single-star parachutes, five-star clusters, and smoke parachutes. The hand-held signals replaced all rifle-projected pyrotechnic ground signals and chemical grenades.

b. Ground Smoke Signals. These signals are self-contained units used by ground soldiers to signal aircraft or to convey information (prearranged signal). The signal consists of a cylindrical smoke pellet, a fuze (thermalite-type ignitacord), an igniter cap, an internal retaining ring, and a striker ring assembled in an aluminum photocan container. These signals produce a smoke cloud that lasts for 13 to 30 seconds. They replaced rifle-projected smoke signals.

## 5-2. CAPABILITIES AND USES

These signals are capable of signaling for communications or illuminating a small area.

a. Signaling (Communication). Effective control of units on the battlefield depends largely on communication. Radio, telephone, voice, messenger, and arm-and-hand signals are communication means that at times are made ineffective by the tactical situation. Pyrotechnic signals are used in such situations to supplement or to take the place of normal communication means. Pyrotechnic signals are prescribed at command level and are prearranged in accordance with SOIs.

b. Illuminating. The illuminating capabilities of pyrotechnic signals are somewhat limited because of their

size. They can be used, however, to light a small area for snort periods when two or more illuminating signals are used at the same time.

### 5-3. HAND-HELD SIGNALS

Star clusters, star parachutes, and smoke parachutes are three hand-held signals used by the Army.

a. Star Clusters. Star clusters are used for signaling and illuminating. They are issued in an expendable launcher, which consists of a launching tube and a firing cap (1, 2, 3, and 4, Figure 5-1). These signals produce a cluster of five free-falling pyrotechnic stars.

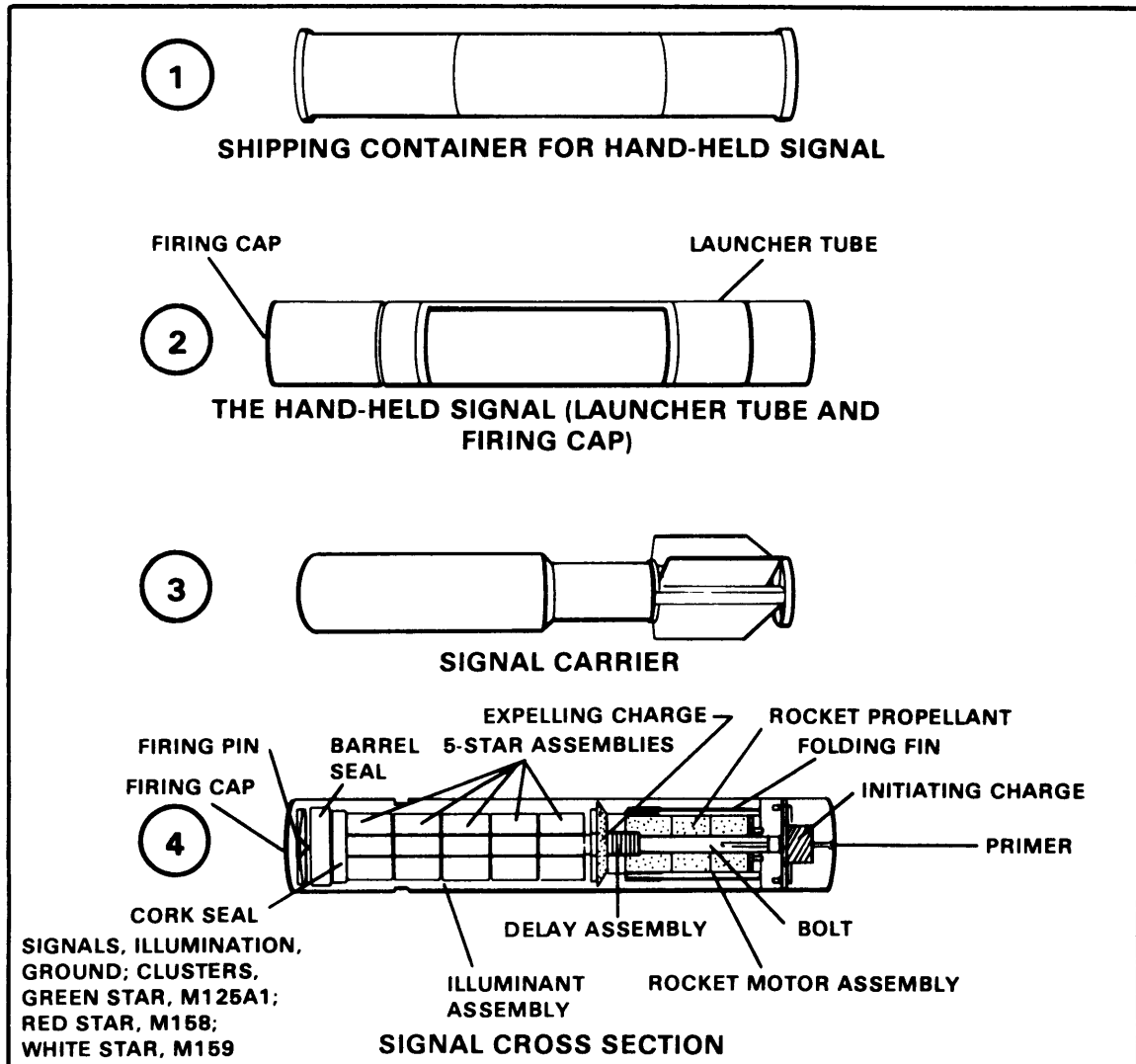

Figure 5-1. Ground pyrotechnic signals.

(1) Types. The current types of star clusters include the M125 and M125A1, green star cluster; the M158, red star cluster; and the M159, white star cluster.

(2) Operation. Operation of hand-held signals should be as follows: (This will not always agree with the instructions found on the launcher tube.) For more detailed information on safety and precautions, refer to TM 9-1370-206-10.

(a) Hold the signal in the left hand, red-knurled band down, with the little finger in alignment with the red band (Figure 5-2).

(b) Withdraw the firing cap from the upper end of the signal.

(c) Point the ejection end of the signal away from the body and slowly push the firing cap onto the signal until the open end of the cap is aligned with the red band.

(d) Grasp the center of the signal firmly with the left hand, holding the elbow tight against the body with the signal at the desired trajectory angle and the firing cap at the bottom. Turn the head down and away from the signal to avoid injury to the face and eyes from particles ejected by the small rocket (Figure 5-2).

(e) Strike the bottom of the cap a sharp blow with the palm of the right hand, keeping the left arm rigid.

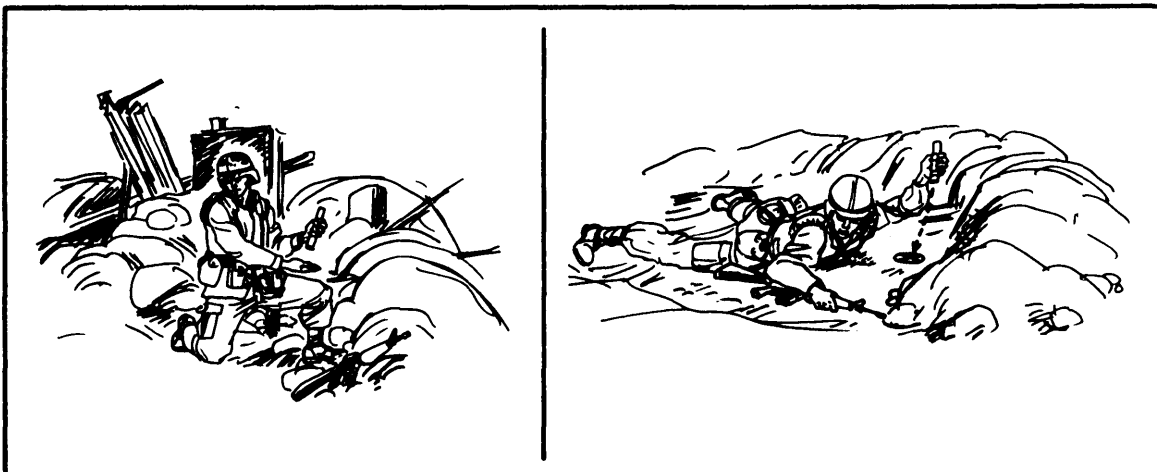

Figure 5-2. Firing the hand-held signal.

NOTE: Before firing the signal, the firer must make sure he has overhead clearance.

(3) Function. When the firing cap is struck, the firing pin is forced into the base of the launcher tube at the primer. When the primer is struck, the flash from the primer ignites an initiating charge of black powder at the base of the signal. Gases from the burning initiating charge expel the signal from the launcher tube (rocket barrel) with a slight recoil. As the signal is expelled, four flexible steel fins unfold to stabilize the signal during flight. After the signal rises approximately 6 meters, the rocket motor, which was ignited by the propelling gases, begins to burn fully, forcing the signal to a height of 200 to 215 meters (650 to 700 feet). At that point, a delay element ignites an ejecting charge, which in turn forces the five-star illuminant cluster out of the nose of the signal body.

(4) Firing data. Star clusters burn 6 to 10 seconds. Their rate of descent is 14 meters (45 feet) per second.

b. Star Parachutes. Star parachutes are also used for signaling and illuminating. They are issued in an expendable launcher that consists of a launching tube and a firing cap. These signals produce a single parachute-suspended illuminant star.

(1) Types. The current types of star parachutes include the M126A1, red star parachute; the M127A1, white star parachute; and the M195, green star parachute.

(2) Operation. These signals are fired in the same manner as star clusters.

(3) Function. These signals function in the same manner as star clusters.

(4) Firing data. The M126- and M127-series of star parachutes rise to a height of 200 to 215 meters. The M126 burns for 50 seconds and the M127 burns for 25 seconds. Their average rate of descent is 2.1 meters per second. The signal can be seen for 50 to 58 kilometers (30 to 35 miles) at night.

c. Smoke Parachutes. Smoke parachutes are used for signaling only. They are issued in an expendable launcher that consists of a launching tube and a firing cap. These signals produce a single, perforated colored smoke canister that is parachute-suspended.

(1) Types. The current types of smoke parachutes include M128A1, green smoke parachute; the M129A1, red smoke parachute; and the M194, yellow smoke parachute.

(2) Operation. These signals are fired in the same manner as star clusters.

(3) Function. These signals function in the same manner as star clusters.

(4) Firing data. Smoke parachutes rise to a height of 200 to 215 meters. The signals emit smoke for 6 to 18 seconds, forming a smoke cloud which persists for 60 seconds. Their rate of descent is 4 meters per second.

#### 5-4. SURFACE TRIP FLARES

Surface trip flares outwardly resemble antipersonnel mines or hand grenades (Figure 5-3). Their primary use is to warn of infiltrating troops by illuminating the field. They may also be used as signals or as booby traps. When activated, the flare produces 50,000 candlepower of illumination.

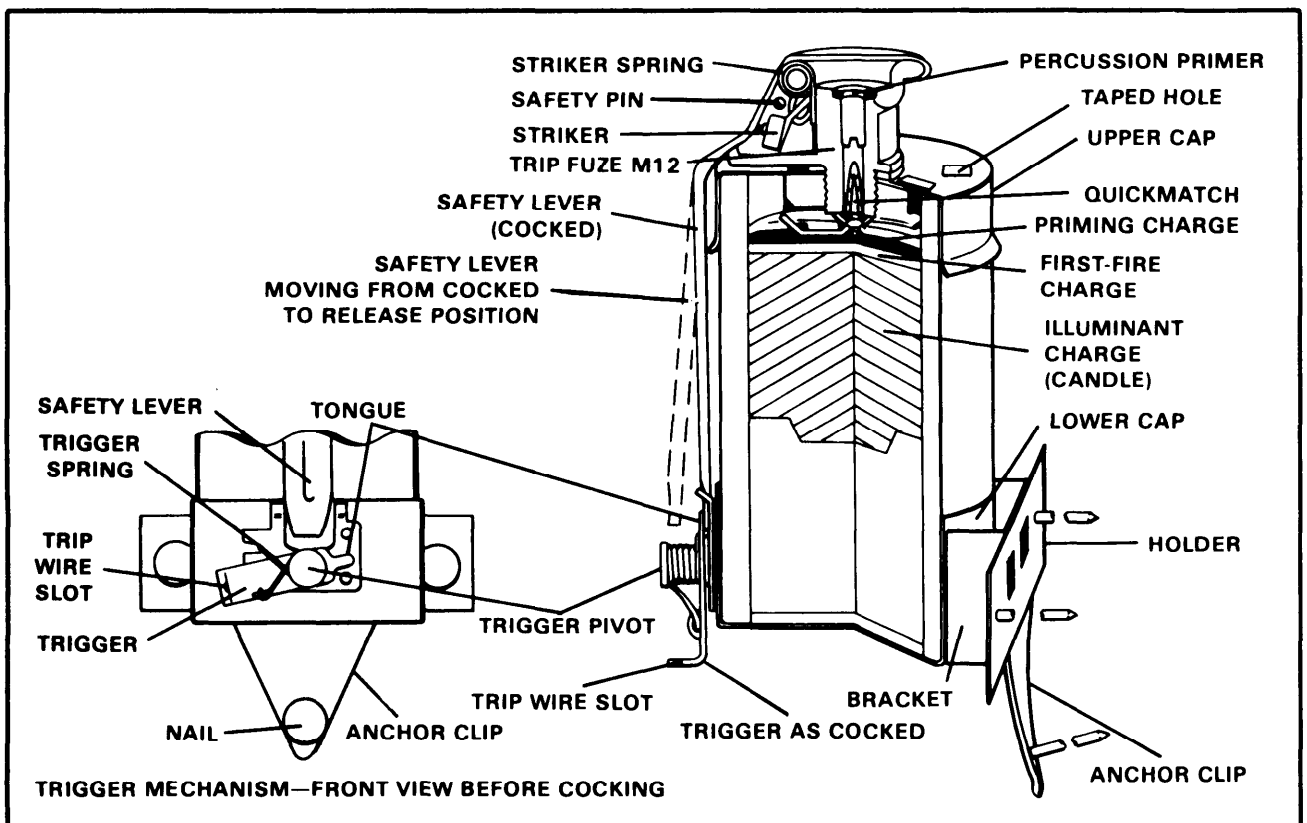

Figure 5-3. Surface trip flares.

## 5-5. SIMULATORS

Simulators are used in training to imitate the sounds and effects of combat detonations.

a. The booby trap simulator M117 (Figure 5-4) is used during training and military exercises. This device allows training in the installation and use of booby traps. When tripped/activated, the simulator functions with a loud report and flash.

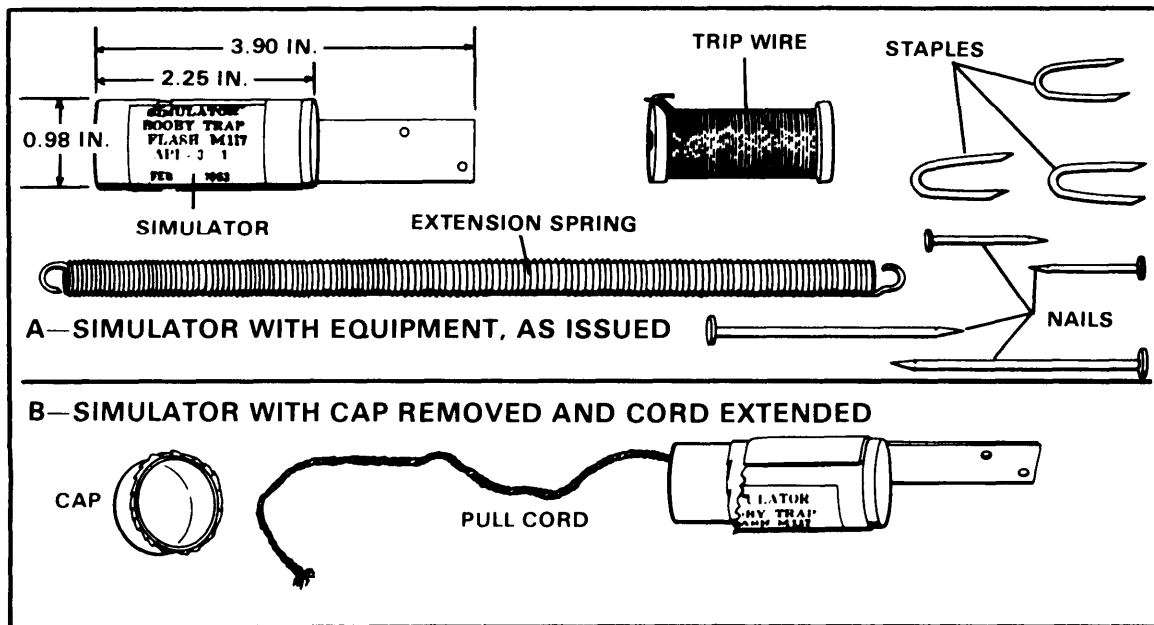

Figure 5-4. M117 simulator.

b. The ground burst simulator M115A2 (Figure 5-5) is used to create battle noises and flash effects during training. It produces a high-pitched whistle that lasts 2 to 4 seconds. The detonation produces a flash and loud report.

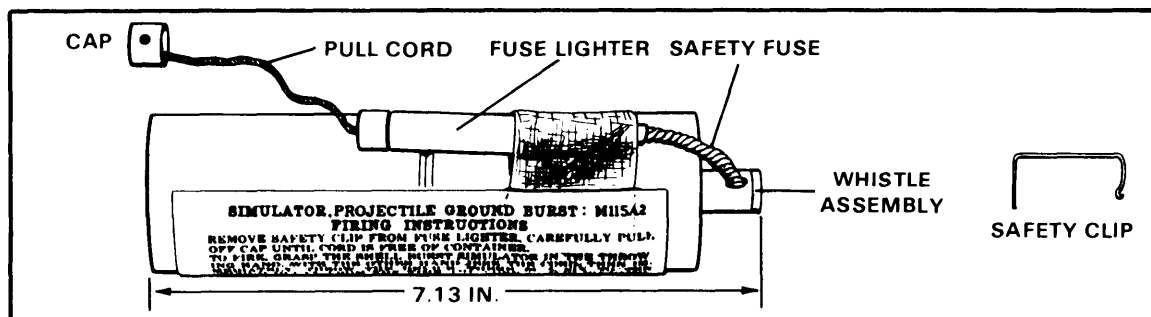

Figure 5-5. M115A2 simulator.



c. The hand grenade simulator M116A1 (Figure 5-6) is used to create battle noises and flashes during training. It differs from the ground burst simulator in that it is shorter and does not emit a high-pitched whistle before detonation. The hand grenade simulator is thrown in the same manner as a live grenade. It creates a loud report and a flash 5 to 10 seconds after ignition.

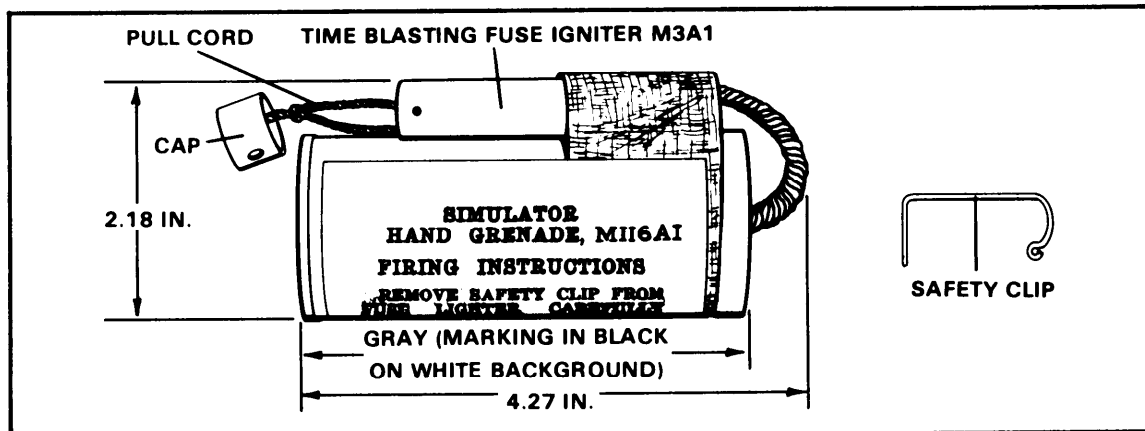

Figure 5-6. M116A1 simulator.

d. The explosive simulator M80 (Figure 5-7) is used during training to depict booby traps and land mines, and also in deactivation training programs. It is used to simulate hand grenades, booby traps, land mines, and rifle or artillery fire.

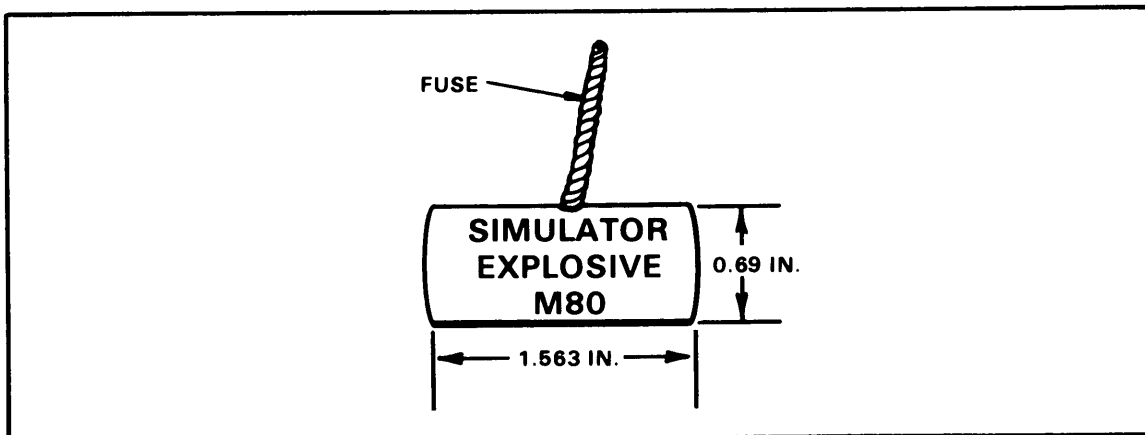

Figure 5-7. M80 simulator.

#### 5-6. ILLUMINATION GROUND SIGNAL KITS

The pen gun flare supports the small-unit leader in fire control, maneuver, and initiating operations such as ambushes.

a. Kit 1. This pen gun flare is identified by a threaded projector with the projectiles being contained in a cloth bandoleer. Each of the signals listed below may be fired from a hand-held projector while encompassed in a bandoleer.

- o Red illumination ground signal, M187.
- o White illumination ground signal, M188.
- o Green illumination ground signal, M189.
- o Amber illumination ground signal, M190.

(1) Contents. The projector and the bandoleer plus seven projectiles/signals make up the signal kit (Figure 5-8). All signals may be obtained and fired separately. The M185 red signal kit contains only red signals. The M186 signal kit contains three red, two white, and two green signals.

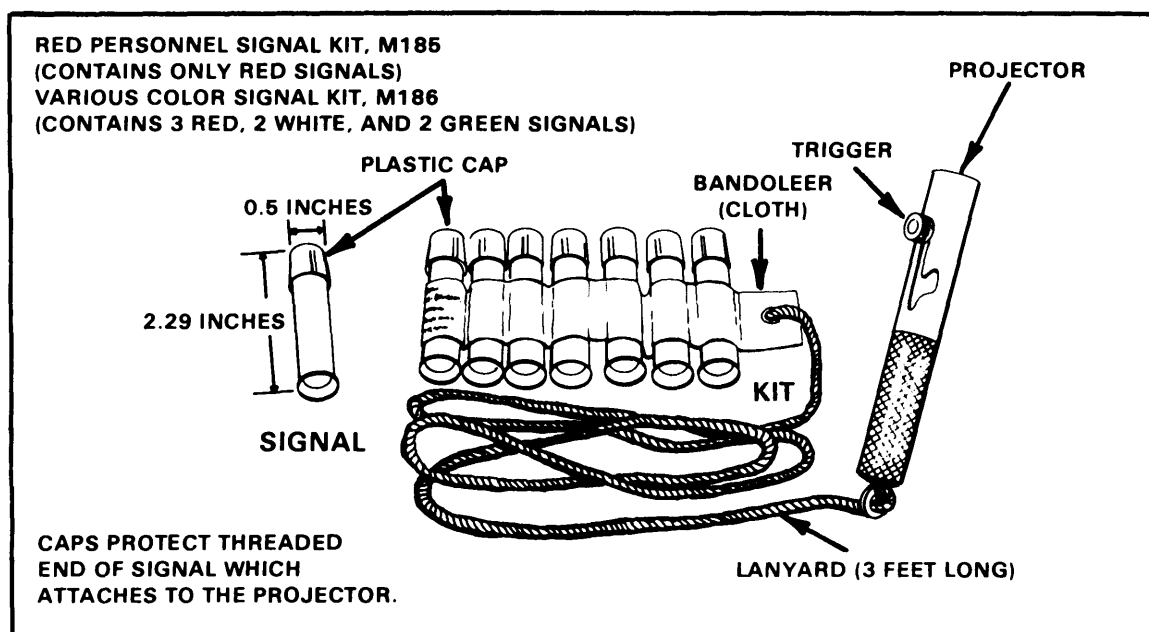

Figure 5-8. Signal kit 1.

(2) Operation. Select the signal to be fired by color. If the bandoleer contains more than one signal of the chosen color, use the one farthest from the lanyard. Remove and discard the plastic cap. Cock the projector by moving the trigger to the safety slot. Carefully thread the projector onto the signal, taking care not to dislodge the trigger from the safety slot. Aim in the

chosen direction. Fire by moving the trigger to the bottom of the firing slot and releasing it with a snap. If the expended signal is on the end of the bandoleer, or if the signals between the expended signal and the end have been used, cut the bandoleer and discard the waste. Return the partially used kit to the barrier bag and seal with tape.

b. Kit 2. This pen gun flare is identified by a force-fitted projector and a plastic bandoleer. With this kit, the projectiles must be removed from the bandoleer before being fired.

(1) Contents. This kit contains only red illumination ground signals. The projector and the bandoleer plus seven signals make up this kit (Figure 5-9). The burning time for these signals is 10 seconds at 100,000 candlepower.

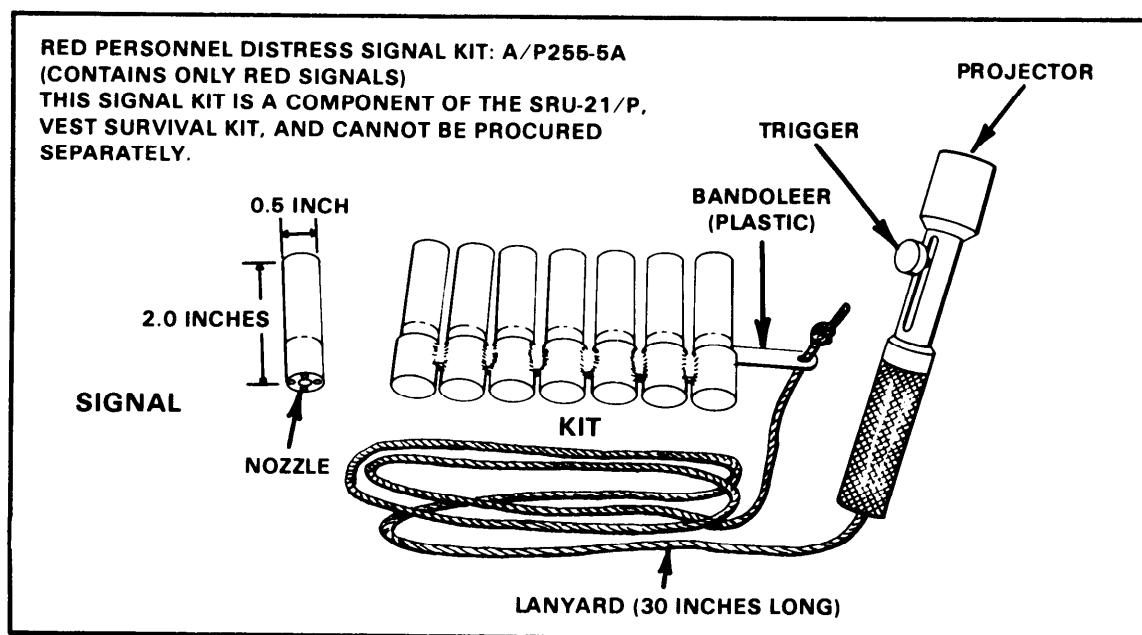

Figure 5-9. Signal kit 2.

(2) Operation. To operate this signal, select and remove the signal to be fired from the bandoleer using the one farthest from the lanyard. Carefully insert the nozzle end of the signal into the projector as far as it will go. Fire by pulling the trigger knob to the rear of the slot and releasing with a snap. Retain the bandoleer for future use. Return the partially used kit to the plastic bag and seal with tape.

APPENDIX A  
THREAT HAND GRENADES

This appendix provides general information on common Threat hand grenade identification, functions, and capabilities. Although the Warsaw Pact nations have an extensive inventory of hand grenades, the majority of these grenades are Soviet-made. As with most Warsaw equipment, older hand grenades remain in circulation and use long after being classified obsolete.

A-1. RGN

Type: fragmentation, offensive.

Weight: 31 ounces.

Body Material: aluminum.

Filler Weight: 115 grams.

Filler Material: RDX.

Fuze Type: sleeve or socket.

Fuze Delay: 3.3 and 4.3 seconds or impact.

Range Thrown: 25 to 45 meters.

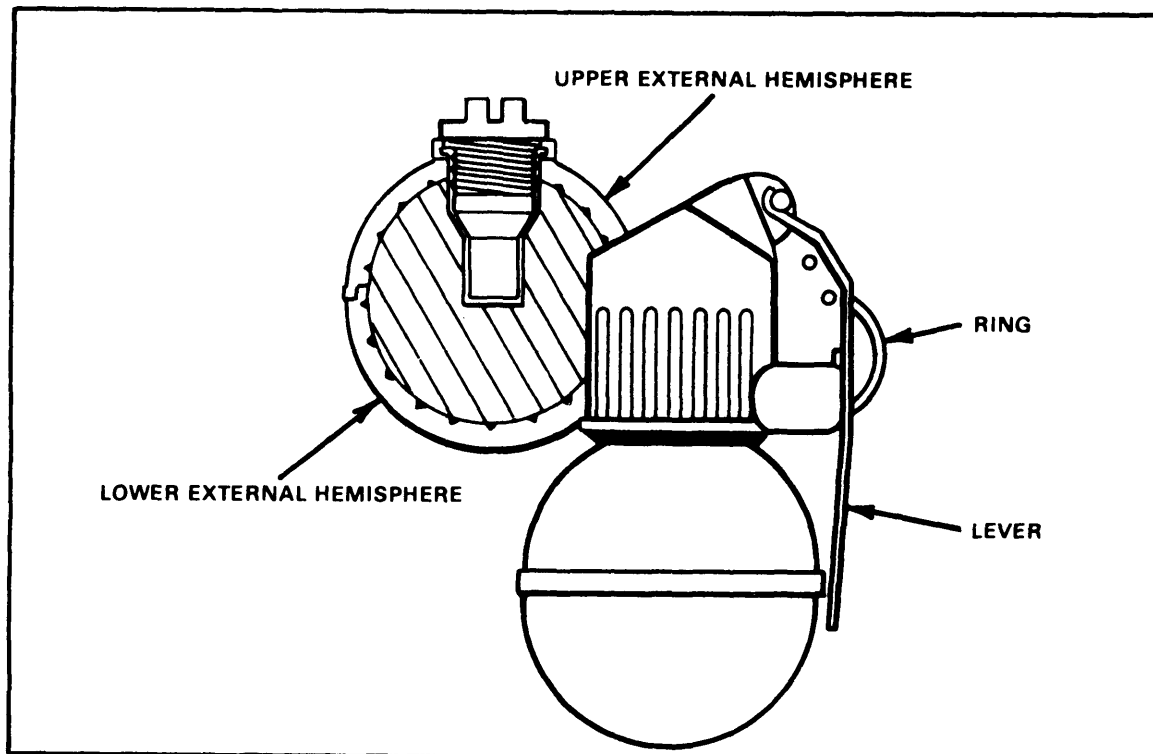

Figure A-1. RGN grenade.

A-2. RGO

Type: fragmentation, defensive.

Weight: 53 ounces.

Body Material: aluminum.

Filler Weight: 92 ounces.

Filler Material: RDX.

Fuze Type: sleeve or socket.

Fuze Delay: 3.3 and 4.3 seconds or shock of impact.

Range Thrown: 25 to 45 meters.

Effective Fragment Radius: 100 meters.

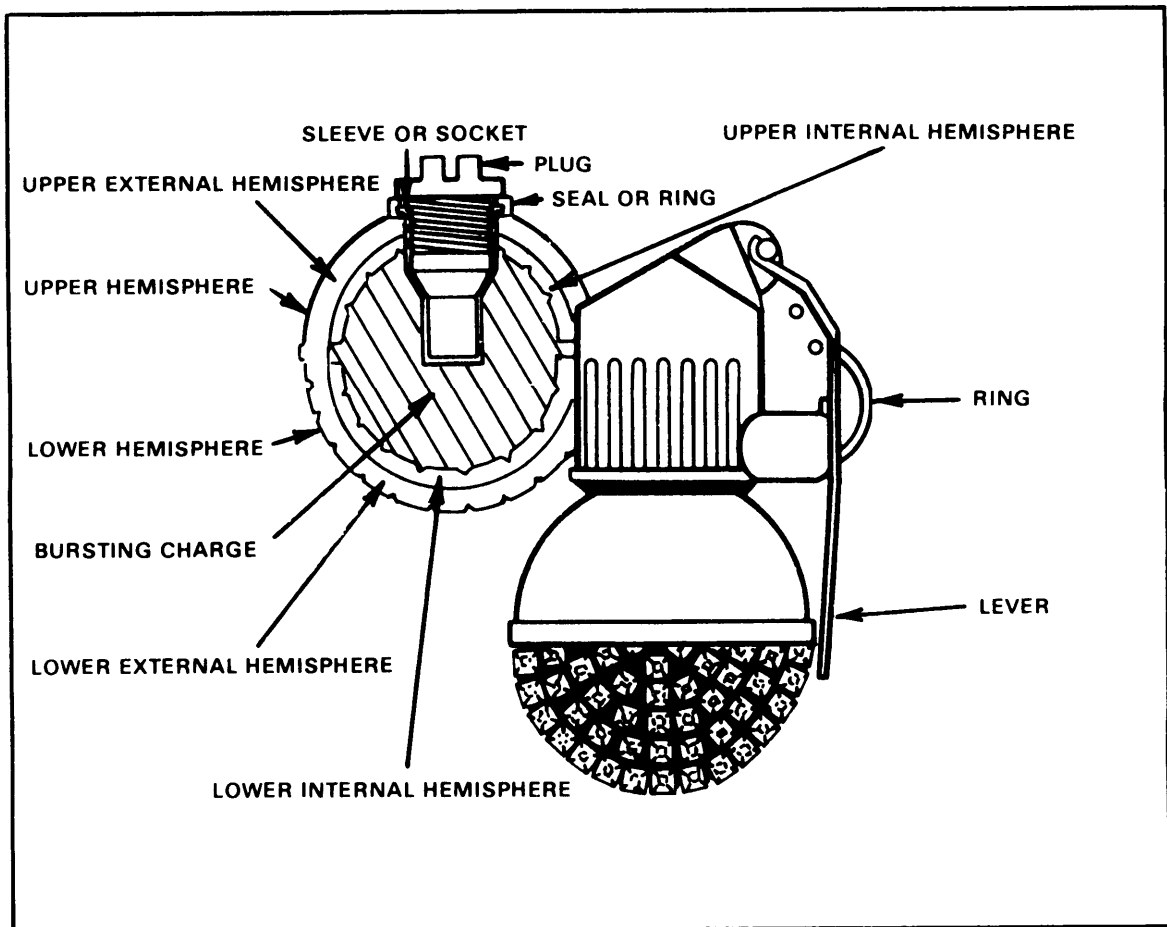

Figure A-2. RGO grenade.

A-3. F1

Type: fragmentation, defensive.

Weight: 60 ounces.

Length: 124 millimeters.

Maximum Diameter: 55 millimeters.

Body Material: cast iron.

Filler Weight: 60 ounces.

Filler Material: TNT.

Fuze Type: delay.

Fuze Delay: 3.2 to 4.2 seconds.

Range Thrown: 30 meters.

Effective Fragment Radius: 15 to 20 meters.

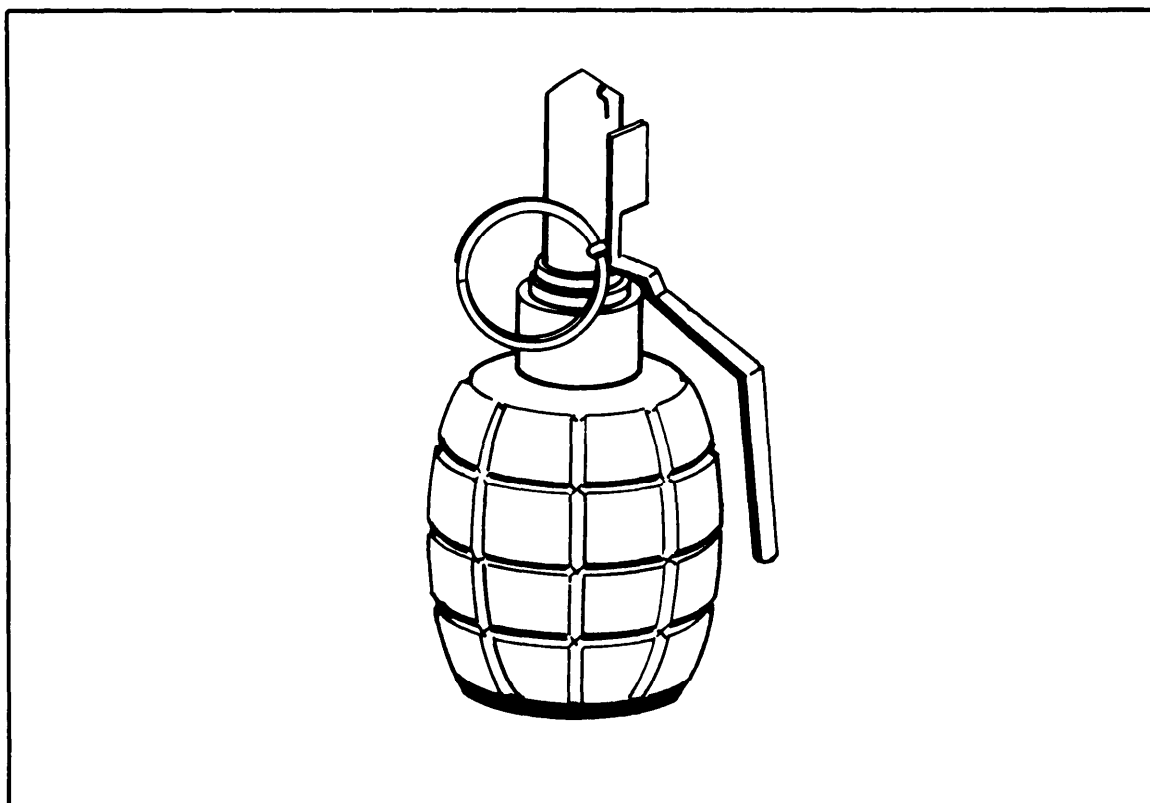

Figure A-3. F1 grenade.

A-4. RKG-3M

Type: antitank (replaces RPG-40, RPG-43, and RPG-6).

Weight, With Fuze: 1.07 kilograms.

Weight of HE Filling: 567 grams.

Type of HE Filling: TNT/RDX.

Penetration: 165 millimeters.

Fuze Type: instantaneous impact.

Effective Fragment Radius: 20 meters.

Length: 362 millimeters.

Maximum Diameter: 5.56 millimeters.

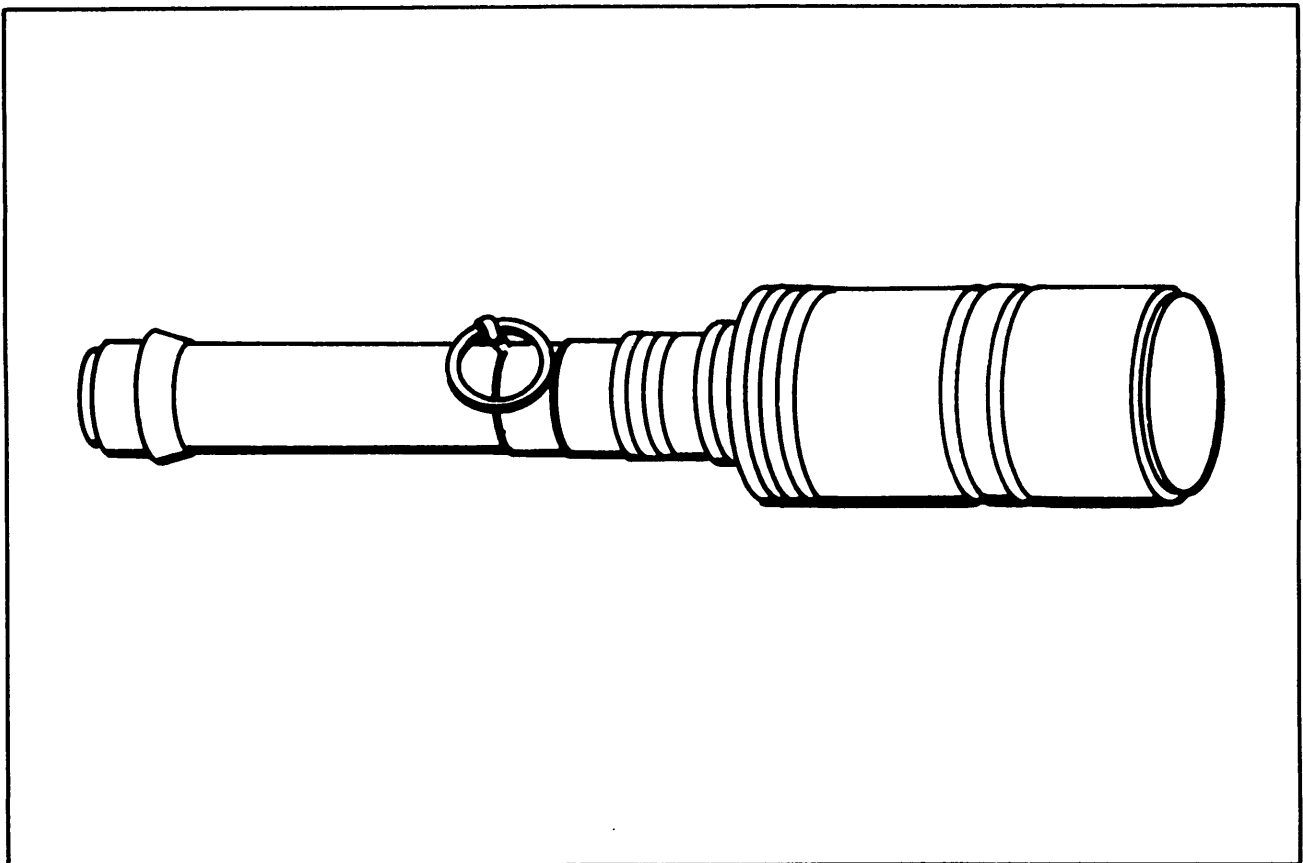

Figure A-4. RKG-3M grenade.

A-5. RGD-5

Type: fragmentation.

Weight: 31 ounces.

Length: 114 millimeters.

Diameter: 57 millimeters.

Weight of Filling: 11 ounces.

Type of Filling: TNT.

Fuze: 3.2 to 4.2 seconds delay UZRG.

Range Thrown: 30 meters.

Effective Fragment Radius: 15 to 20 meters.

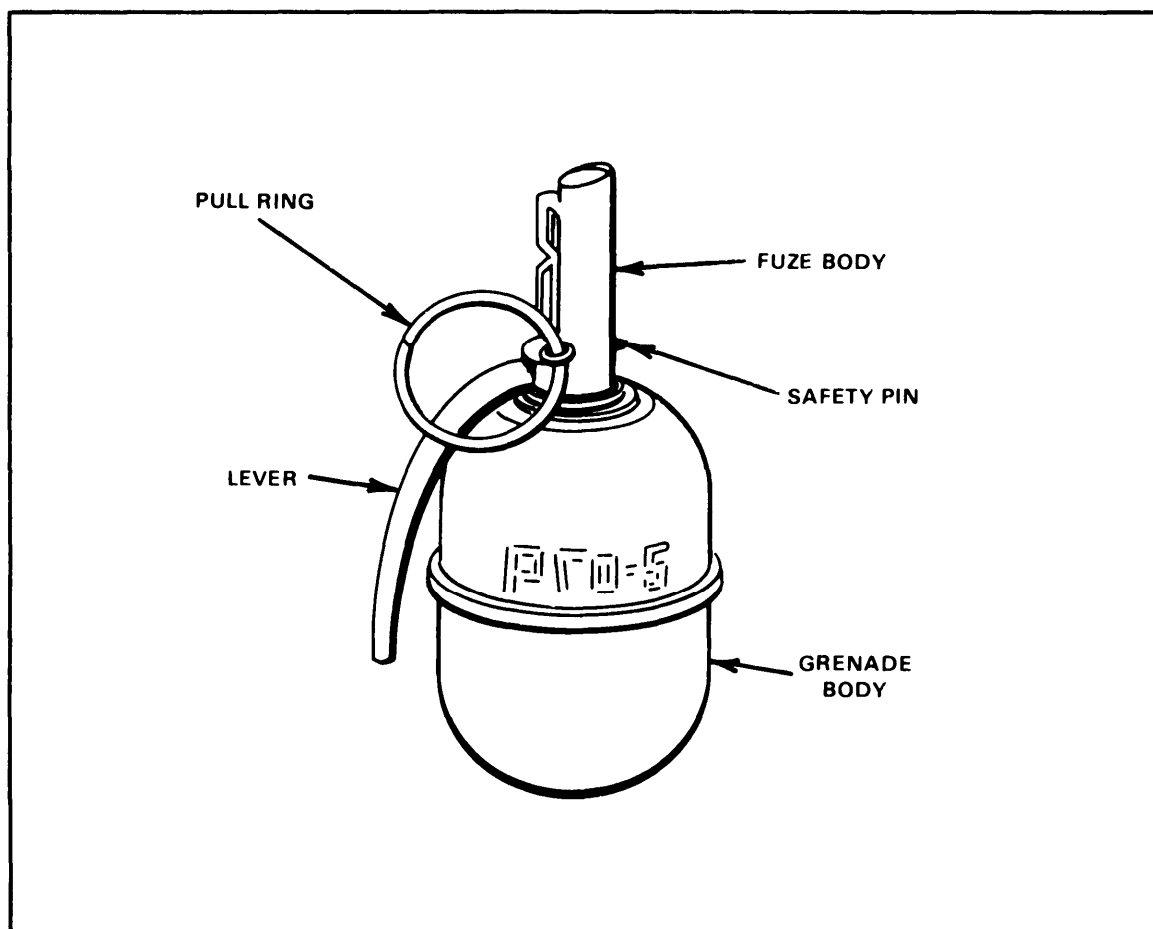

Figure A-5. RGD-5 grenade.



A-6. RG42

Type: fragmentation.

Weight: 436 grams.

Length: 121 millimeters.

Maximum Diameter: 54 millimeters.

Body Material: steel.

Filler Weight: 118 grams.

Filler Material: pressed TNT.

Fuze Type: delay.

Fuze Delay: 3 to 4 seconds.

Identifying Markings: P-42.

Range Thrown: 35 meters.

Effective Fragment Radius: 2 to 5 meters.

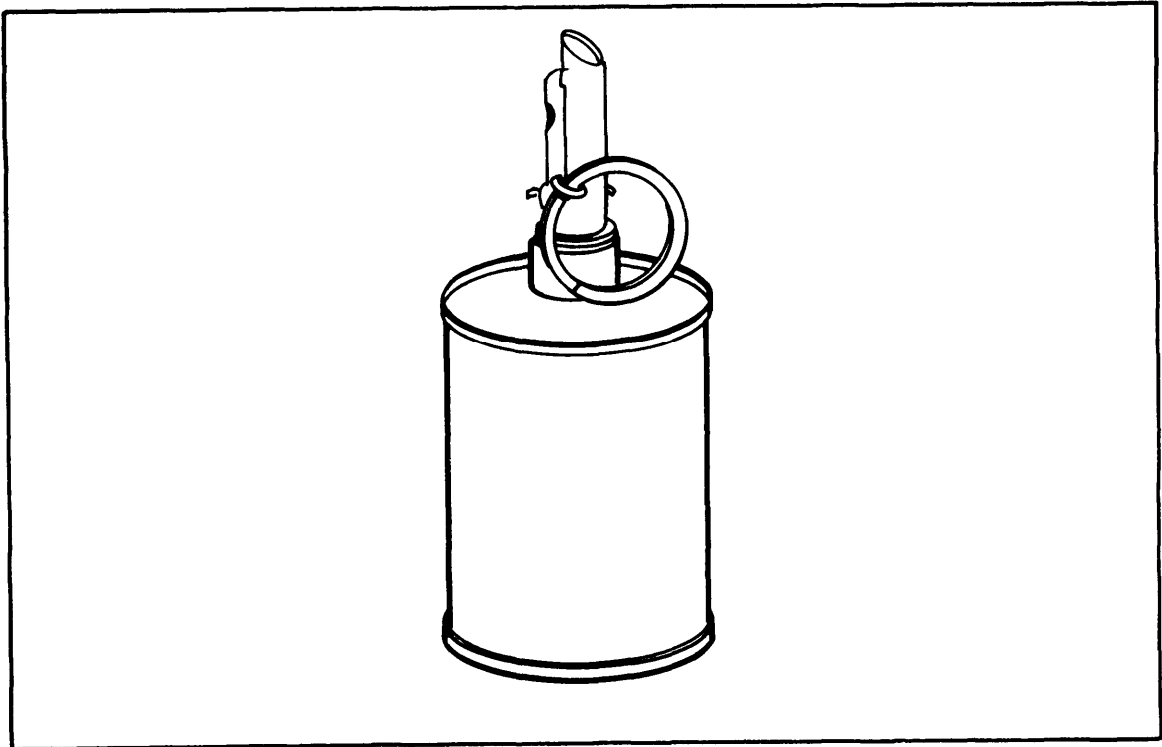

Figure A-6. RG42 grenade.

A-7. RGD-1

Type: smoke.

Burning Time: 1 to 1 1/2 minutes.

Average Smoke Area: 460 square meters.

Throwing Distance: 35 meters.

Weight: 500 grams.

Length: 222 millimeters.

NOTE: It is waterproof and it floats. It is capable of screening water operations with white or black smoke.

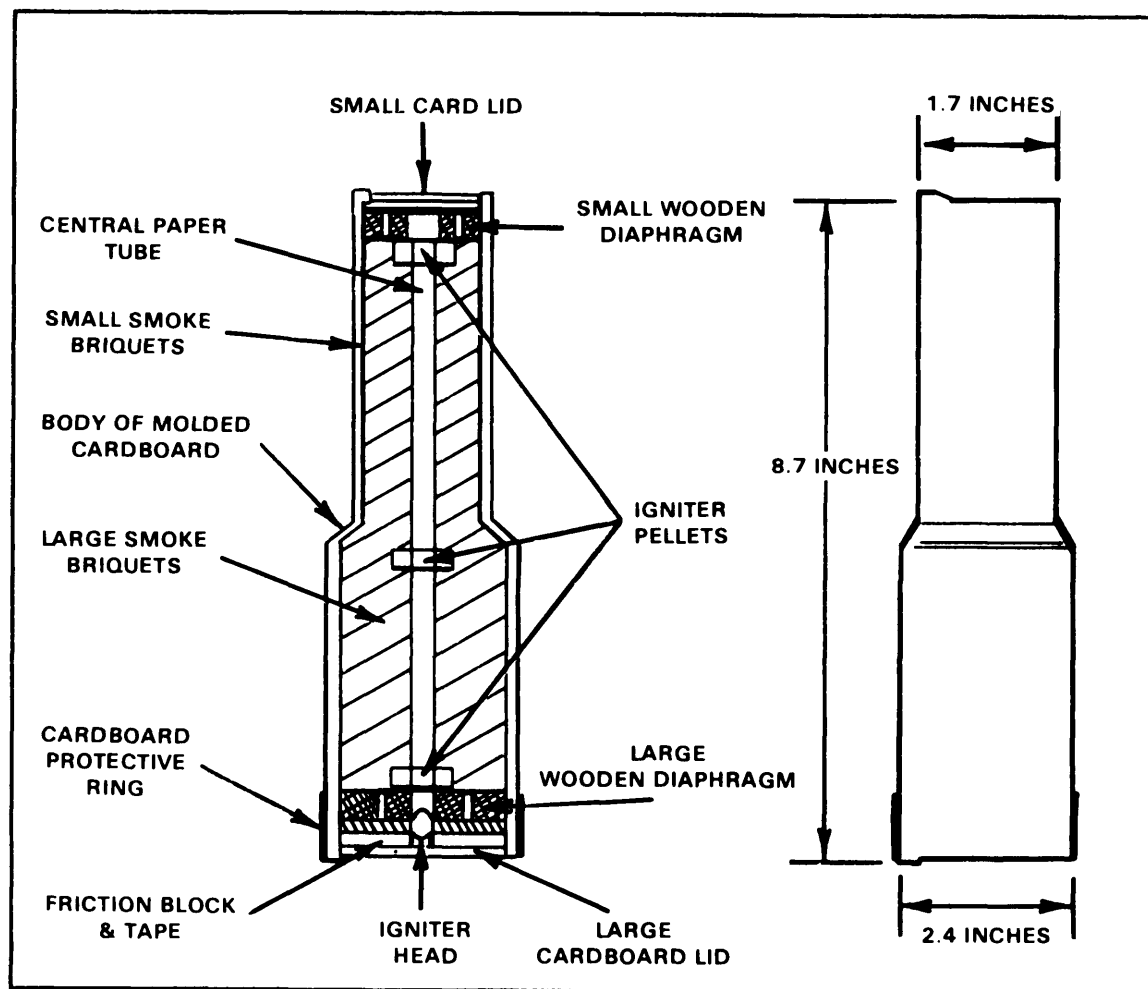

Figure A-7. RGD-1 smoke grenade.

A-8. RGD-2

Type: smoke.

Burning Time: 1 1/2 minutes.

Average Smoke Area: 160 square meters.

Throwing Distance: 35 meters.

Weight: 500 grams.

Length: 240 millimeters.

NOTE: It is damp proof, but it cannot support water operations.

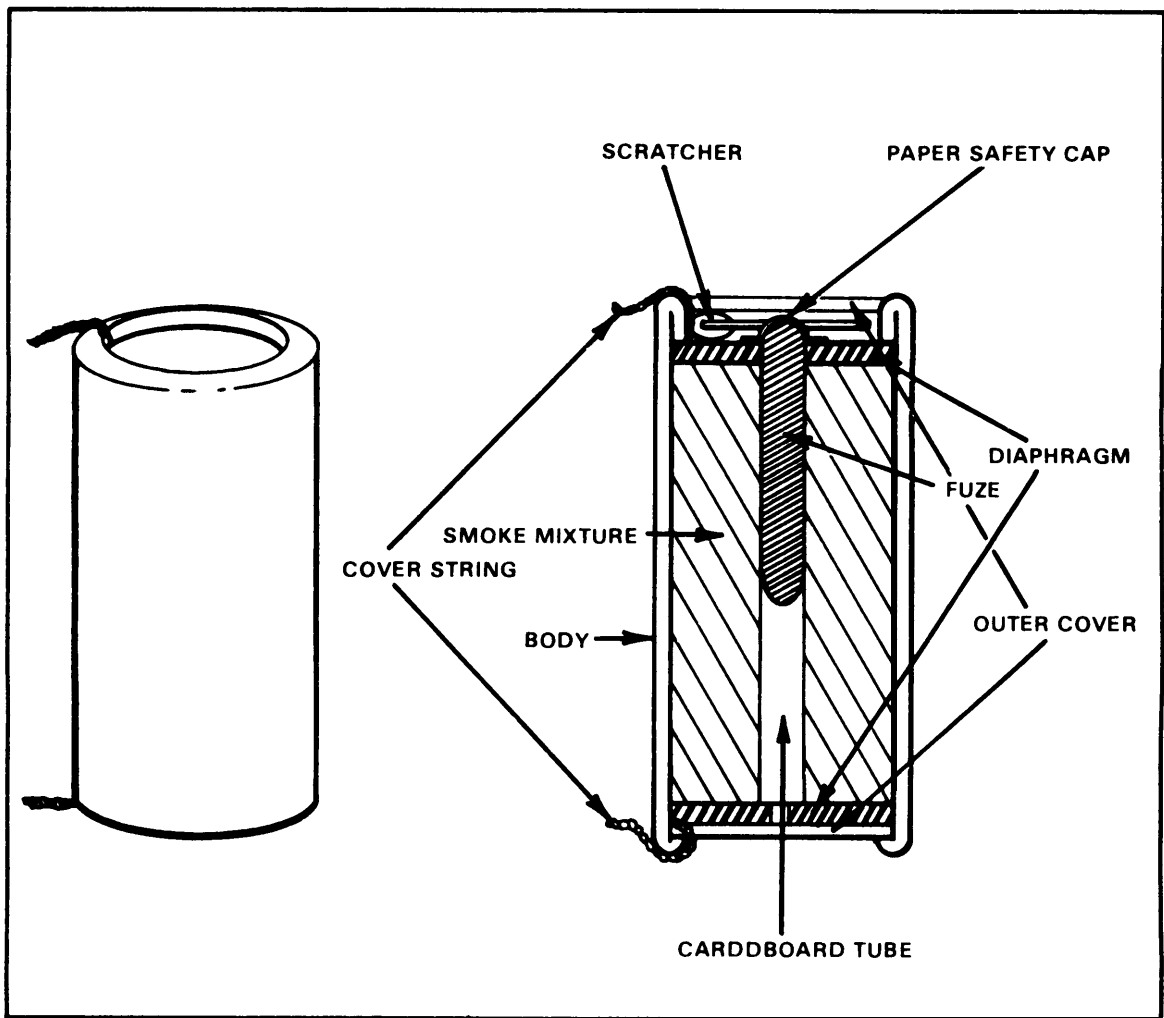

Figure A-8. RGD-2 smoke grenade.

## APPENDIX B

## LIVE HAND GRENADE RANGE OPERATIONS CHECKLIST

This appendix is designed to assist leaders in the safe operation of a basic live hand grenade range. As a checklist, it does not provide the answers, it asks the questions for leaders to answer. Modification of the checklist for other types of live hand grenade training (collective training, STX, and so forth) is expected.

## SUGGESTED CHECKLIST

## I. BECOME AN EXPERT.

## A. Review Written Material.

1. Review AR 385-63.
2. Review FM 23-30 and TM 9-1330-200-12 w/ch 1-10.

## B. Check Out the Range.

1. Visit range control and read installation range instructions.
2. Recon the range, preferably while in use.

## II. DETERMINE REQUIREMENTS.

## A. Personnel.

1. OIC.
2. Safety officer.
3. Assistant safety officer.
4. NCOIC .
5. Ammunition NCO.
6. Ammunition personnel.
7. Target detail.
8. Tower operator.
9. Assistant instructors.
10. RATELOs.

11. Guards, as required.
12. Medics, with required medical supplies.
13. Truck driver.

B. Equipment.

1. Equipment for safety personnel and trainees is Kevlar or steel helmet, flak vest, LBE, and ear plugs.
2. Range packet and clearance form.
3. Safety fan and diagram.
4. Appropriate publications pertaining to training that will be conducted (FM 23-30 and TM 9-1330-200-12 w/ch 1-10) .
5. Lesson plans, status reports, and reporting folders.
6. Range flag.
7. Communications.
  - a. Commercial phones.
  - b. Mounted courier.
  - c. FM radios and RC-292, if necessary.
  - d. Field telephones and wire.

NOTE: Two means of communication are required.

8. PA set with backup bullhorns.
9. Marked helmets for control personnel.
10. Ambulance or required dedicated evacuation vehicle; the driver must have knowledge of the route to the hospital.
11. Ear plugs for all personnel; have extras on hand.
12. Water for drinking and cleaning.
13. Qualification scorecards.
14. Tables and chair, if needed.

15. Targets should be required for operation of range. (Bunkers or personnel target 1/4-inch steel E-type silhouette.)

### III. OCCUPY THE RANGE.

#### A. Set Up.

1. Request range control permission to occupy the range.
2. Establish good communications.
3. Have the following designated areas prepared:
  - a. Parking.
  - b. Ammunition point.
  - c. Medical station.
  - d. Water point.
  - e. Mess.
  - f. Helipad.

#### B. Inspection.

1. Inspect range for operational condition:
  - a. Make sure the impact area is raked and clear of debris.
  - b. Check all throwing pits for sharp edges or unlevel throwing surfaces.
  - c. Check to see if the knee walls meet standards.
2. Raise the flag when occupying or firing, according to local SOP.
3. Ensure range personnel are in proper uniform and the equipment is in position.

#### C. Preparation.

1. Conduct safety briefing to include admin personnel on range.
2. Organize personnel into throwing orders.

3. Receive permission to commence firing from range control.

#### IV. CONDUCT PRE-THROW (TRAINING).

##### A. Teach the Soldiers.

1. To attach grenades to ammunition pouches.
2. The proper grip.
3. The proper throwing techniques.
4. The throwing commands.

##### B. Execute Practice Throws (10 or more as required).

#### V. INSPECT GRENADES.

##### A. Open Canister and Visually Inspect.

1. If grenade is packed upside down, turn in grenade. (See page 2-2, TM 9-1330-200-12.)
2. If safety pin or safety clip is missing, turn in grenade.

##### B. Remove Grenade from Canister and Inspect.

1. If grenade body is cracked, turn in grenade.
2. If fuze lugs are broken, turn in grenade.
3. If safety lever is bent or broken, turn in grenade.
4. The safety pin must have either a diamond crimp or a 45-degree spread; if not, turn in grenade. (See page 3-5, TM 9-1330-200-12.)
5. If pull ring is cracked, turn in grenade.
6. If fuze is loose, turn in grenade.

#### VI. ISSUE GRENADES.

NOTE: Issue grenades to soldiers and secure them to ammo pouches under supervision of safety NCO. The safety NCO at the live grenade issue point will physically inspect each soldier as the live grenades are being attached.

A. Old-Type Ammo Pouches.

1. Ensure safety lever is placed in the carrying sleeve.
2. Ensure pull ring on safety pin is in a downward position.
3. Ensure that carrying strap is wrapped around the fuze, safety lever, and pull ring.
4. Ensure that carrying strap is snapped and secure.

B. New-Type Ammo Pouches.

1. Ensure grenade is positioned in grenade pocket with the safety lever inside the pocket.
2. Ensure pull ring on safety pin is in a downward position.
3. Ensure that carrying strap is snapped and secure.
4. After the live grenades have been attached to the ammunition pouches, each soldier will be instructed not to remove the live grenades until told to do so by the pit safety NCO in the live pit.

VII. THROW THE GRENADES.

NOTE: Soldiers must be briefed on safety procedures for dropped grenades.

NOTE: The range OIC must be positioned in the tower to observe throw-phase procedures and count grenade explosions for purposes of grenade accountability.

A. Assign a Pit Safety NCO to Each Throwing Pit.

1. The safety NCO directs soldiers to specific throwing pit safety NCO.
2. The pit safety NCO observes movement of soldier to the pit.
3. The soldier identifies the throwing arm to pit safety NCO.
4. The pit safety NCO directs soldier to appropriate position of pit, based on left or right throwing arm.



5. The pit safety NCO directs soldier to remove a grenade from the ammo pouch with the proper grip.

6. The pit safety NCO directs soldier to remove safety clip and prepare to throw. (From this point on, the pit safety NCO does not remove his eyes from the throwing hand until completion of the throw. The pit safety NCO signals the tower that the soldier is prepared to throw. )

**WARNING: IF A GRENADE IS DROPPED IN THE PIT THE PIT SAFETY NCO FORCES THE SOLDIER OUT OF THE PIT INTO THE DESIGNATED SAFE AREA. AND FOLLOWS HIM**

B. Order the Throw.

1. When all throwing pits are ready, the tower NCO commands THROW, and the pit safety NCO repeats the command THROW.

NOTE: Only one pit will throw at a time.

2. The soldier throws the grenade and then drops to cover.

**WARNING: IF A SOLDIER RELEASES THE SAFETY LEVER BUT FAILS TO THROW THE GRENADE. THE PIT SAFETY NCO FORCEFULLY REPEATS THE COMMAND TO THROW. AND IF NECESSARY. THE PIT SAFETY NCO THROWS THE GRENADE HIMSELF**

3. The tower NCO commands CLEAR after observing each grenade detonate.

4. The soldier prepares to throw a second grenade, repeating required steps.

5. The pit safety NCO directs the soldier to exit the live pit area after a final ALL CLEAR from the tower.

**WARNING: "COOKING OFF" WILL BE NOT BE DONE WITH LIVE GRENADES DURING TRAINING**

VIII. COMPLETE THE MISSION.

A. Clear the Range.

1. Close down range control according to local SOP.
2. Remove all equipment and ammunition from range.
3. Police range, rake the impact area, and perform other maintenance as required by local SOP.
4. Request a range inspection from range control when ready to be cleared.

B. Turn In Paperwork and Equipment.

1. Submit after-action report to headquarters.
2. Report any noted safety hazards to proper authorities.
3. Turn in all unexpended grenades in original grenade containers to the ASP, along with all safety pins and packing residue from all detonated grenades.

## APPENDIX C

## HAND GRENADE SAFETY CONSIDERATIONS

This appendix lists precautions and other considerations to be followed by hand grenade users. It should be used with Appendix B, Live Hand Grenade Range Operations Checklist, to educate leaders to safely conduct hand grenade training.

## C-1. GENERAL PRECAUTIONS

Observe general precautions applicable to the use of any ammunition. More specific instructions to grenade users include --

- a. Do not open grenade containers or remove protective devices until just before use.
- b. Never make unauthorized modifications to hand grenades.
- c. Do not remove the safety clip or the safety pin until the grenade is to be thrown.

(1) A safety clip can be removed and reattached to a hand grenade if the safety pin is still in place.

(2) Never attempt to reinsert a safety pin. Once the safety pin has been pulled, the grenade must be thrown.

## C-2. TRAINING PRECAUTIONS

Treat any thrown grenade that fails to detonate as a dud, regardless of safety pin, safety clip, or safety lever status.

- a. Know a grenade's status. It may be --
  - o Safe -- a grenade with all safety devices intact.
  - o Live -- a thrown grenade from the instant it is released until the expected fuze time has elapsed.
  - o A dud -- any thrown grenade that failed to detonate after the expected fuze time has elapsed.
- b. During training, the pit NCO determines a dropped grenade's status (safe/live/dud).

c. Throwers must consider the flight of the grenade to make sure no obstacle will alter the flight of the grenade or cause it to bounce back toward them.

d. Make sure that the impact area is level and free of debris before throwing the casualty-producing hand grenade in training.

e. Do not handle, approach, recover, or otherwise tamper with dud live grenades. These will be taken care of by explosive ordnance disposal personnel.

f. Observe caution when using hand grenades with igniting type fuzes (M14 TH3, AN-M18, M7A3, and AN-M8). These grenades ignite with a flash and should be thrown at least 10 meters from all personnel to avoid hazardous conditions.

### C-3. DUDS

Duds must be regarded as dangerous. The following procedures must be followed if a grenade does not detonate.

a. M69 Practice Grenade. Wait 5 minutes before defuzing. Keep the bottom of the grenade oriented in a safe area. Place the dud fuze in a sand-filled container and return it to issuing facility.

b. Fragmentation Grenade. The thrower and supervisor wait in the throwing pit for 5 minutes before returning to a covered area. Notify EOD immediately. Do not throw any hand grenades into the area of the dud until it has been neutralized. If range facilities provide, continue training on adjacent impact areas separated by berms.

### C-4. DROPPED LIVE HAND GRENADES

In the event a casualty-producing grenade is dropped accidentally after the safety pin has been removed, the throwing pit safety NCO is responsible for reacting accordingly. He is responsible for the safety of the thrower, and he decides what actions are most appropriate. His actions are dependent upon many factors, such as the safety design of the throwing pit, the location of the dropped grenade, the location of the thrower, and possibly his ability to physically move the thrower. All of these factors need to be considered before the safety pin is pulled.

a. Throwing Pit With Knee Wall. It is recommended that all throwing pits for live grenade training have knee walls (Figure C-1). Knee walls provide the quickest and safest means of reacting to a dropped grenade. In most

instances, the throwing pit safety NCO would react to a dropped live grenade by yelling GRENADE (to alert all other personnel in the area) and by physically pushing the thrower over the knee wall, falling on top of him. If the hand grenade were dropped over the knee wall, the throwing pit safety NCO would yell GRENADE and force the thrower to the ground inside the throwing pit.

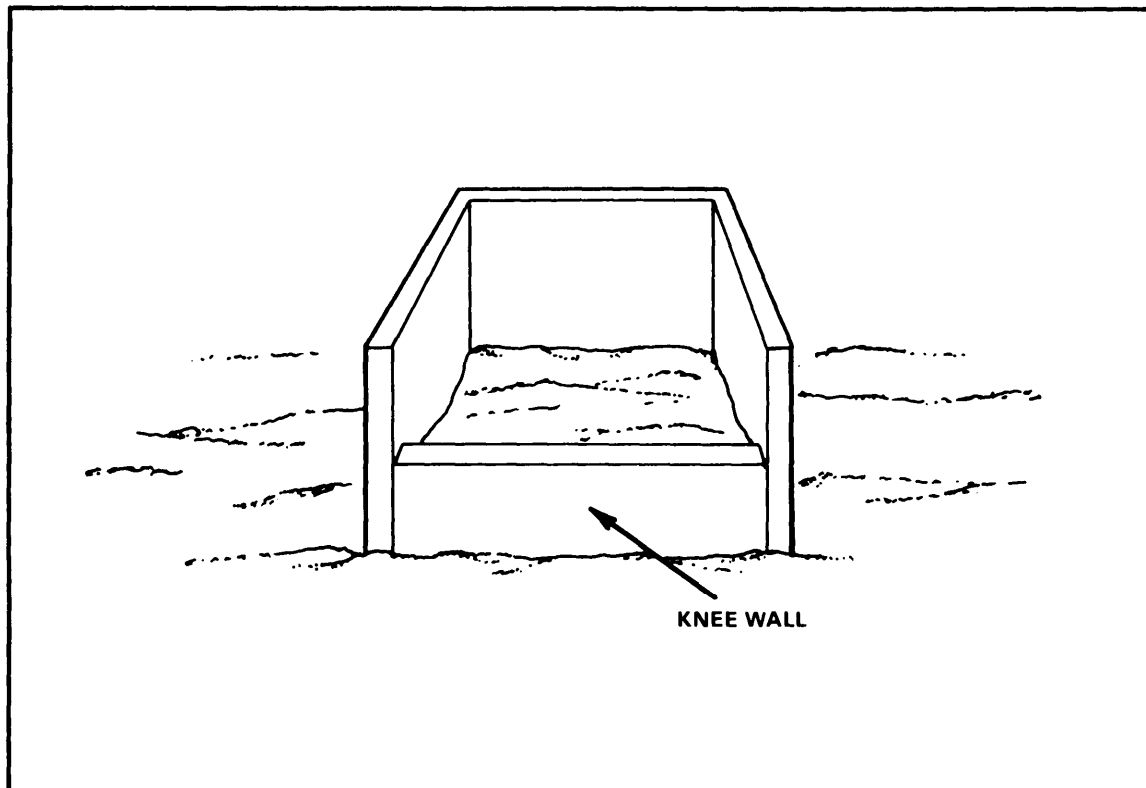

Figure C-1. Throwing pit with knee wall.

b. Throwing Pit Without Knee Wall. Throwing pits that do not have knee walls must have safety pits attached to both sides (Figure C-2). In most instances, the throwing pit safety NCO would react to a dropped live grenade by yelling GRENADE (to alert other personnel in the area) and by physically moving the thrower out of the throwing pit and into a safety pit. If the hand grenade were dropped to the rear of the throwing pit, the throwing pit safety NCO would yell GRENADE, and force the thrower over the front of the throwing pit. He would follow him over. Any attempt by the throwing pit safety NCO to throw the dropped grenade out of the throwing pit is discouraged. The safety NCO's first responsibility is the thrower's safety. His immediate actions must be to remove the thrower from the danger area.

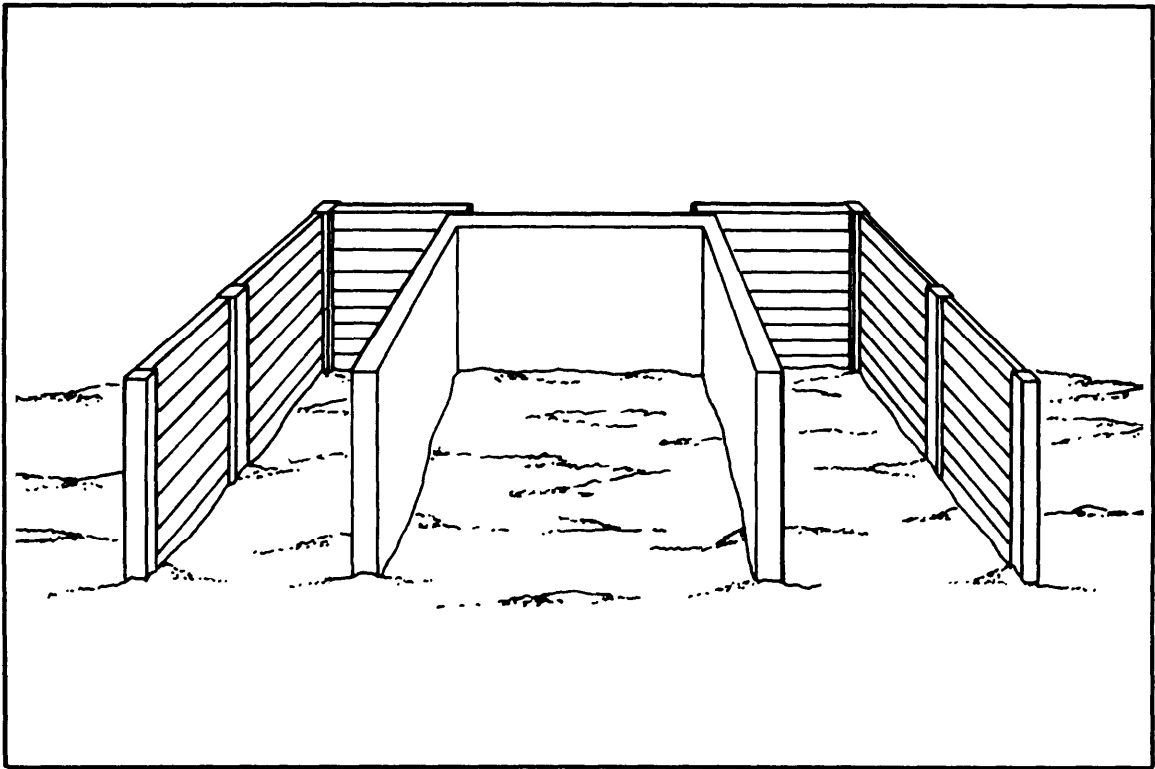

Figure C-2. Throwing pit with safety pits.

c. Sumps. Grenades will not be kicked or thrown into sumps. Soldiers will move from the danger area and drop to the prone position with helmets facing the direction of the grenade. This minimizes the soldier's exposure and maximizes the protection of the helmet.

#### C-5. GRIP

Hold the safety lever firmly. An insufficient grip on the safety lever could result in the striker rotating and striking the primer that ignites the delay element. This can occur on most grenades without the safety lever being detached from the grenade.

#### C-6. HELICOPTERS

Do not throw fragmentation or white phosphorous grenades from low-flying or hovering helicopters. The fragments present a hazard to the aircraft and its passengers. The burst of white phosphorous chemical may be brought into the helicopter by the rotor wash, creating significant safety hazards. As a general rule, throwing hand grenades from medium- or high-level flying helicopters should be limited to mission-critical situations.

## C-7. AIRBORNE

Do not attach hand grenades on ammunition pouches during airborne operations; carry them in the main body of the rucksack instead. The following are suggested techniques:

- a. Remove grenades from canisters and tape the safety pin and safety lever to the grenade. (Fold back the end of the tape for a quick release.)
- b. Return grenades to the canisters for carrying after opening them to inspect each grenade.

## APPENDIX D

## OBSOLETE HAND GRENADES

This appendix provides data for identifying and understanding the characteristics and capabilities of obsolete US hand grenades. Although these grenades are no longer common to the US inventory, the majority of them are still in use by other services or nations.

## D-1. M30 PRACTICE GRENADE

This practice grenade simulates the M26-series of fragmentation hand grenades for training purposes (Figure D-1). The grenade adds realism to training and familiarizes the soldier with the functioning and characteristics of the fragmentation hand grenade.

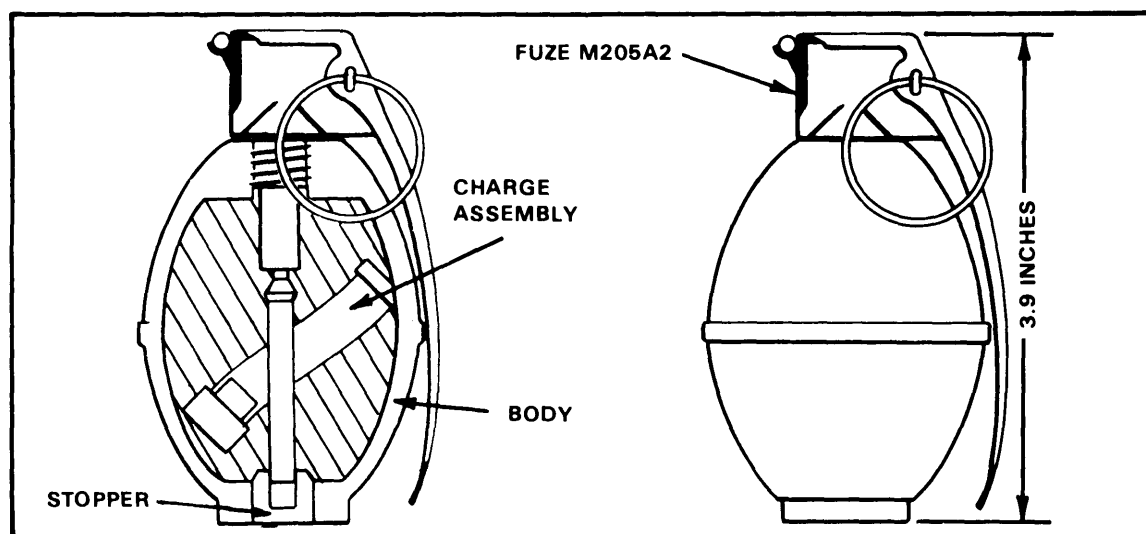

Figure D-1. M30 practice grenade.

- a. Body. Cast iron. (The grenade body is reusable.)
- b. Fuze. M205A1 or M205A2.
- c. Weight. 16 ounces.
- d. Safety Clip. Figure 1-7.
- e. Capabilities. The average soldier can throw the grenade 40 meters. The M30 grenade emits a small puff of white smoke after a delay of 4 to 5 seconds and makes a loud popping noise.
- f. Color and Markings. Light blue with white markings.

**WARNING: FUZE FRAGMENTS MAY EXIT THE HOLE IN THE BASE OF THE GRENADE BODY, CAUSING INJURY**



## D-2. MK1 ILLUMINATING HAND GRENADE

The MK1 illuminating hand grenade is a ground signaling and illuminating item (Figure D-2). Its uses are similar to ground pyrotechnic signals, except that the grenade burns only at ground level, whereas pyrotechnic signals burn in flight or while suspended from a parachute. The MK1 should not be used in deep mud or swampy ground because the grenade may become embedded in the ground, which would result in little or no illumination. The grenade burns with a very hot flame and may be used as an incendiary agent. Because of its incendiary nature, caution should be exercised to prevent fires, which would be detrimental to tactical operations.

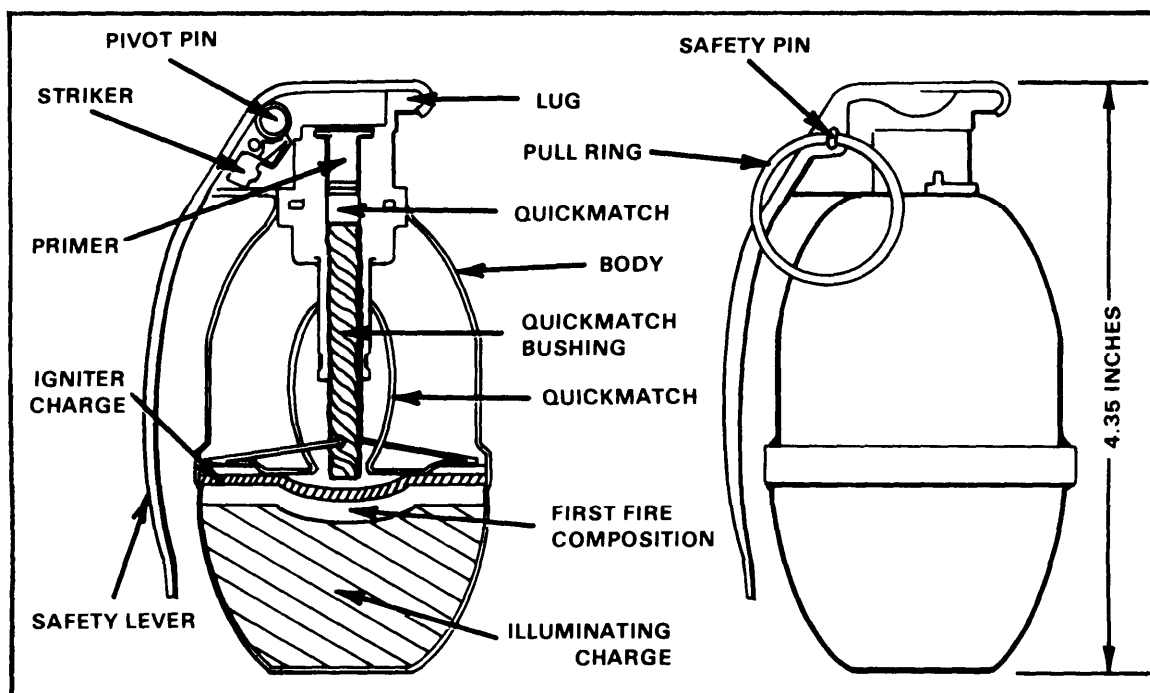

Figure D-2. MK1 illuminating grenade.

- a. Body. Sheet steel.
- b. Filler. 3.5 ounces of illuminating pyrotechnic composition.
- c. Fuze. Special igniter. The special igniter differs from other igniting-type fuzes in that it contains a quick match, rather than a powder-delay train. The quick match has a burning time of 7 seconds, after which it sets off an igniter charge. The igniter charge initiates the burning process of the grenade's filler.
- d. Weight. 10 ounces.

e. Capabilities. The average soldier can throw the grenade 40 meters. The filler will burn for 25 seconds, producing 55,000 candlepower. The MK1 grenade will illuminate an area 200 meters in diameter.

f. Color and Markings. White with black markings (old); unpainted with black markings (new).

**WARNING: AVOID LOOKING DIRECTLY AT THE ILLUMINATING GRENADE AS IT BURNS. THE INTENSITY OF THE LIGHT MAY DAMAGE THE RETINA.**

#### D-3 . MK2 FRAGMENTATION HAND GRENADE

This grenade is used to supplement small arms fire against the enemy in close combat (Figure D-3). The grenade produces casualties by high velocity projections of fragments.

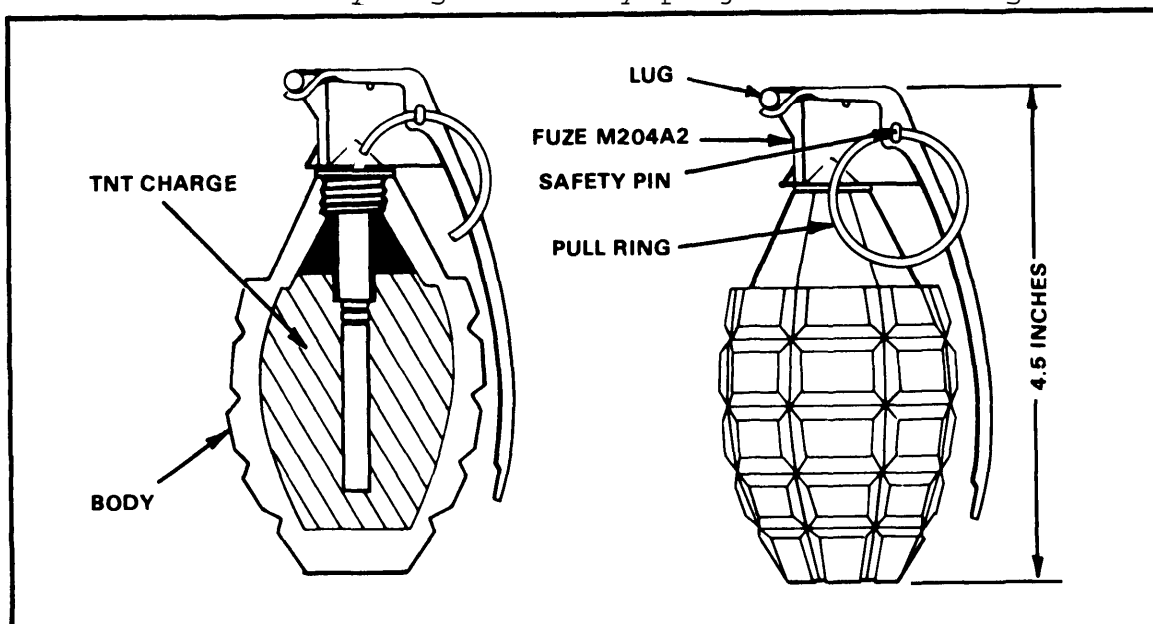

Figure D-3. MK2 fragmentation hand grenade.

- a. Body . Cast iron.
- b. Filler. TNT (flaked or granular).
- c. Fuze. M204A1, M204A2.
- d. Weight. 21 ounces.
- e. Capabilities. The average soldier can throw the grenade 30 meters. The grenade has a bursting radius of 10 meters.
- f. Color. Olive drab body with a single yellow band indicates a high explosive filler.

**WARNING: IF THE FUZE IS LOOSE, DO NOT TRY TO TIGHTEN IT. THIS COULD SET OFF THE GRANULAR TNT IN THE GRENADE.**

D-4. M26 AND M26A1 FRAGMENTATION HAND GRENADES

These grenades are used to supplement small arms fire against the enemy in close combat (Figure D-4). The grenade produces casualties by high velocity projection of fragments.

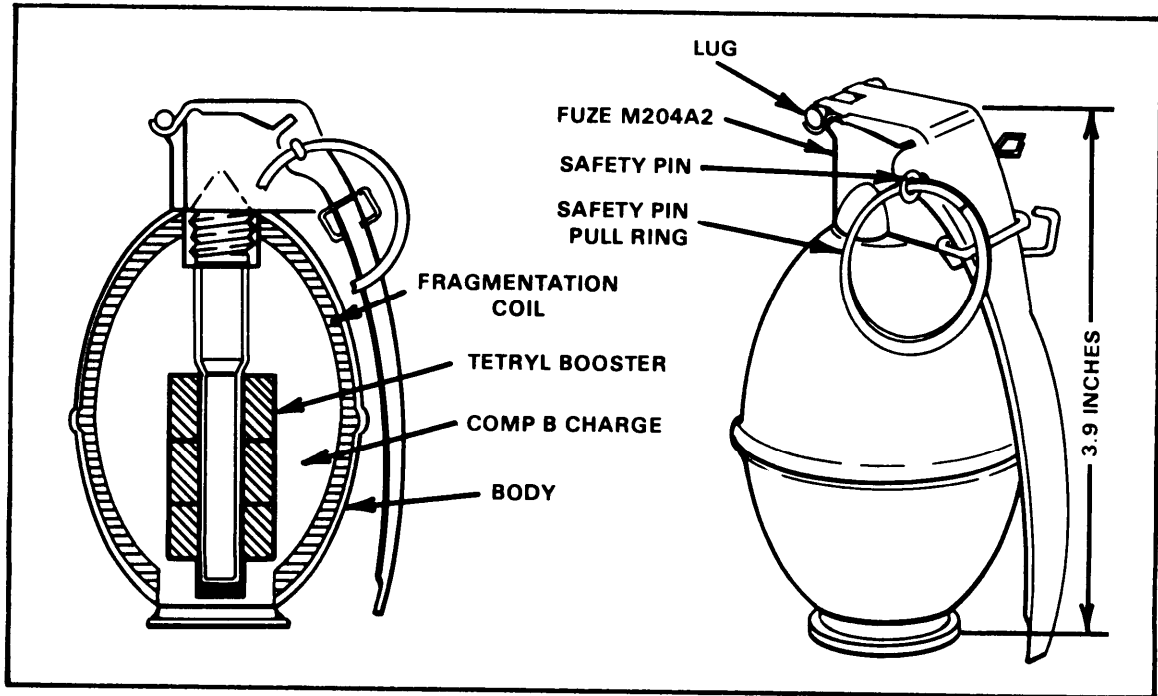

Figure D-4. M26 and M26A1 fragmentation hand grenades.

- a. Body. Cast iron.
- b. Filler. TNT (flaked or granular).
- c. Fuze. M204A1, M204A2.
- d. Weight. 21 ounces.
- e. Capabilities. The average soldier can throw the grenade 40 meters. The grenade has an effective casualty radius of 15 meters.
- f. Color and Markings. Olive drab body with a single yellow band at the top and yellow markings, which indicate a high explosive filler.

**WARNING: ALTHOUGH THE CASUALTY PRODUCING RADIUS OF THIS GRENADE IS 15 METERS, FRAGMENTS CAN DISPERSE UP TO 230 METERS**

D-5. M7 AND M7A1 CN RIOT CONTROL HAND GRENADES

These grenades contain only CN (tear gas) for a filler (Figure D-5). They differ in the amount of filler they contain.

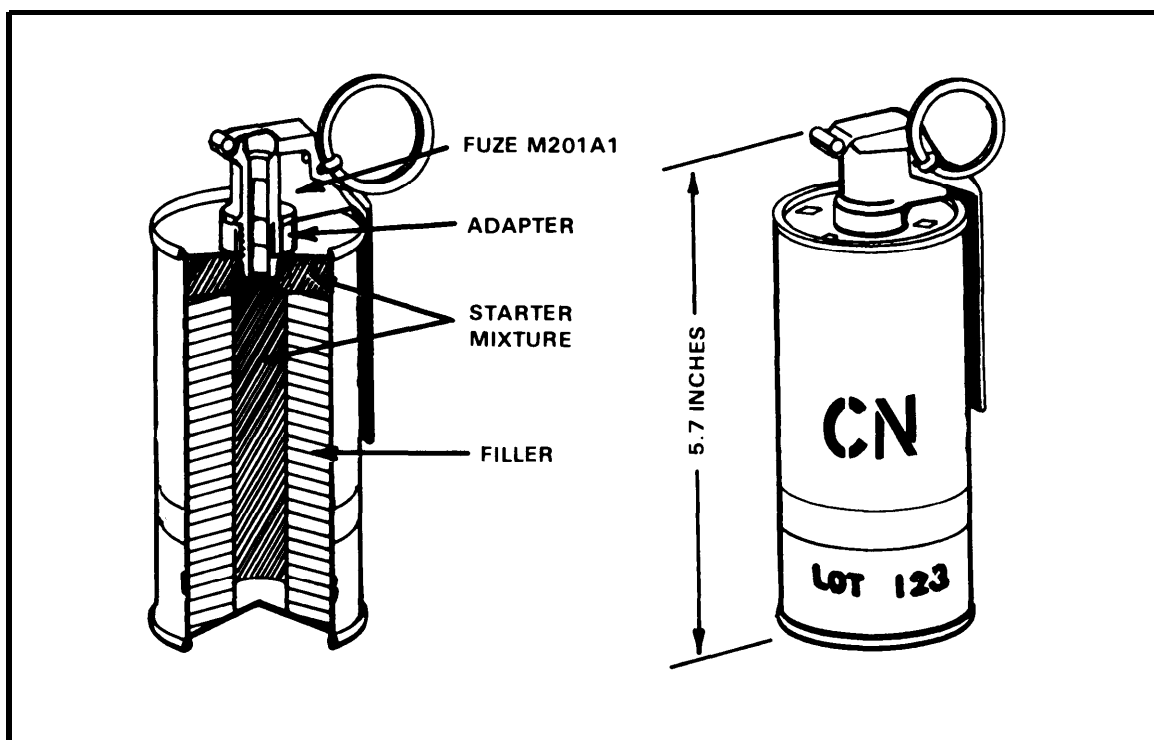

Figure D-5. M7 and M7A1 tear gas grenades.

- a. Body. M7 grenade -- same as the M6 (paragraph D-7a).  
M7A1 grenade -- same as the MA1 (paragraph D-7a).
- b. Filler. M7 grenade -- 10.25 ounces of CN.  
M7A1 grenade -- 12.5 ounces of CN.
- c. Fuze. M201A1.
- d. Weight. M7 grenade -- 17 ounces.  
M7A1 grenade -- 18.5 ounces.
- e. Capabilities. The average soldier can throw either grenade 35 meters. Both grenades produce a dense cloud of irritant agent for 20 to 60 seconds.
- f. Color and Markings. The M7 and M7A1 grenades have a gray body with a single red band and red markings.

**WARNING: FRIENDLY FORCES SHOULD DON PROTECTIVE MASKS BEFORE USING THESE GRENADES.**

D-6. ABC-M7A2 HAND GRENADE

This grenade is used to control counterinsurgencies and for other tactical missions (Figure D-6). It also may be used to simulate casualty agents during training. It looks the same as the M7A1 in Figure D-5.

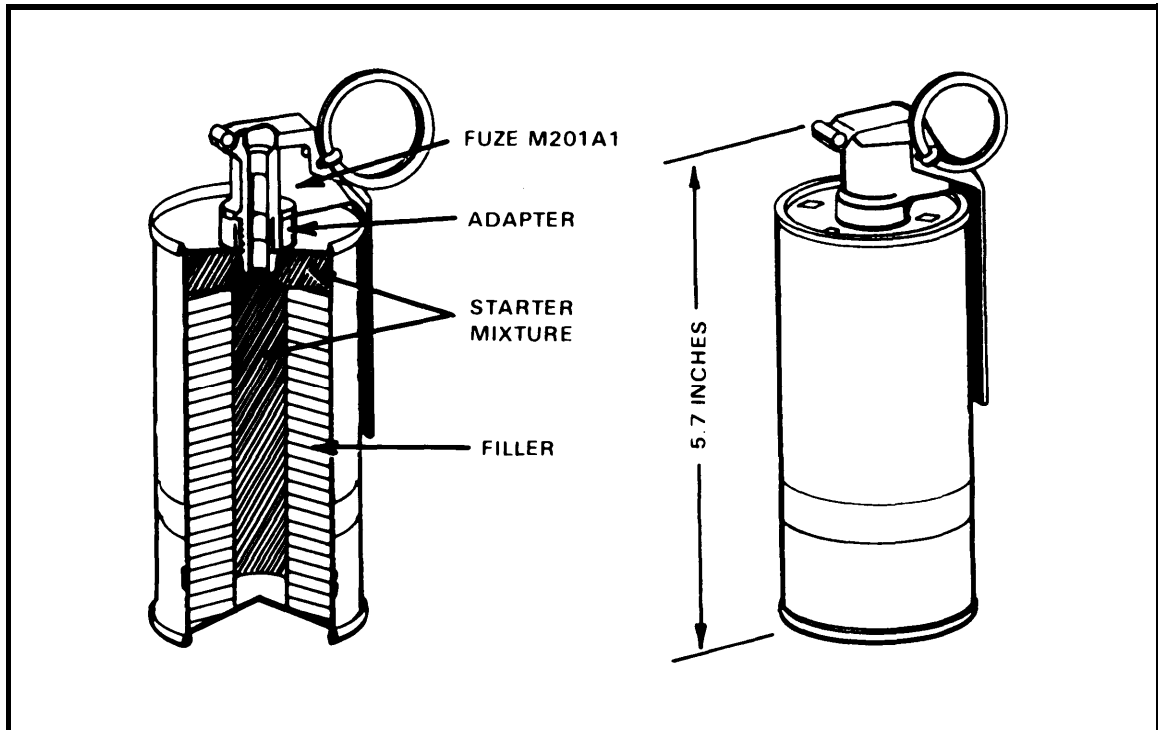

Figure D-6. ABC-M7A2 hand grenade.

- a. Body. Sheet metal.
- b. Filler. CN-pyrotechnic composition.
- c. Fuze. M201A1.
- d. Weight. 18.5 ounces.
- e. Capabilities. The average soldier can throw the grenade 35 meters. The grenade produces a dense cloud of irritant agent for 20 to 60 seconds.
- f. Color and Markings. The M7A2 grenades have a gray body with a single red band and red markings.

**WARNING: FRIENDLY FORCES SHOULD DON PROTECTIVE MASKS BEFORE USING THIS GRENADE**

D-7 . M6 AND M6A1 CN-DM RIOT CONTROL HAND GRENADES

The M6 and M6A1 grenades contain a combination mixture of CN and DM (Figure D-7). They differ chiefly in external appearance and the manner in which the filler is combined.

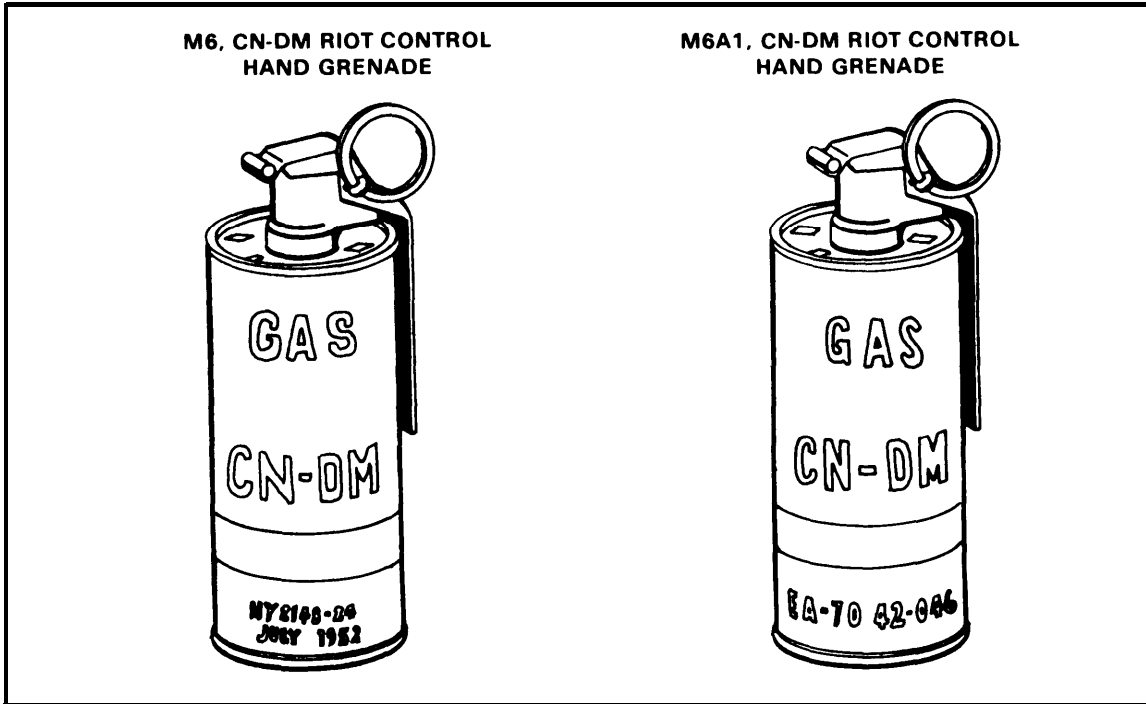

Figure D-7. M6 and M6A1 riot control hand grenades.

- a. Body. Sheet metal. The M6 has six emission holes at the top and two rows of nine emission holes each along the sides. The M6A1 grenade has four emission holes at the top and one at the bottom.
- b. Filler. M6 grenade -- 10.5 ounces of CN-DM mixture.  
M6A1 grenade -- 9.5 ounces of CN-DM mixture.
- c. Fuze. M201A1.
- d. Weight. M6 grenade -- 17 ounces.  
M6A1 grenade -- 20 ounces.
- e. Capabilities. The average soldier can throw either grenade 35 meters. Both grenades emit a dense cloud of irritant agent for 20 to 60 seconds.
- f. Color and Markings. The M6 and M6A1 grenades have a gray body with a single red band and red markings. (Under the standard color-coding system, the single red band and

red markings indicate a nonpersistent, riot control filler. A double red band and red markings indicate a persistent riot control filler, and any combination of green bands and green markings indicates a casualty-producing filler. Currently, there are no casualty-producing agents in grenade form.)

**WARNING: FRIENDLY FORCES SHOULD DON PROTECTIVE MASKS BEFORE USING THESE GRENADES**

#### D-8. ABC-M25A1/ABC-M25A2 RIOT CONTROL HAND GRENADES

The ABC-M25A1 riot control hand grenade is a bursting munition with an integral fuze (Figure D-8). The M25A2 grenade is an improved version of the M25A1 grenade. The two types of grenades differ primarily in body construction. They are used to deliver all three types of riot control agents presently used in hand grenades.

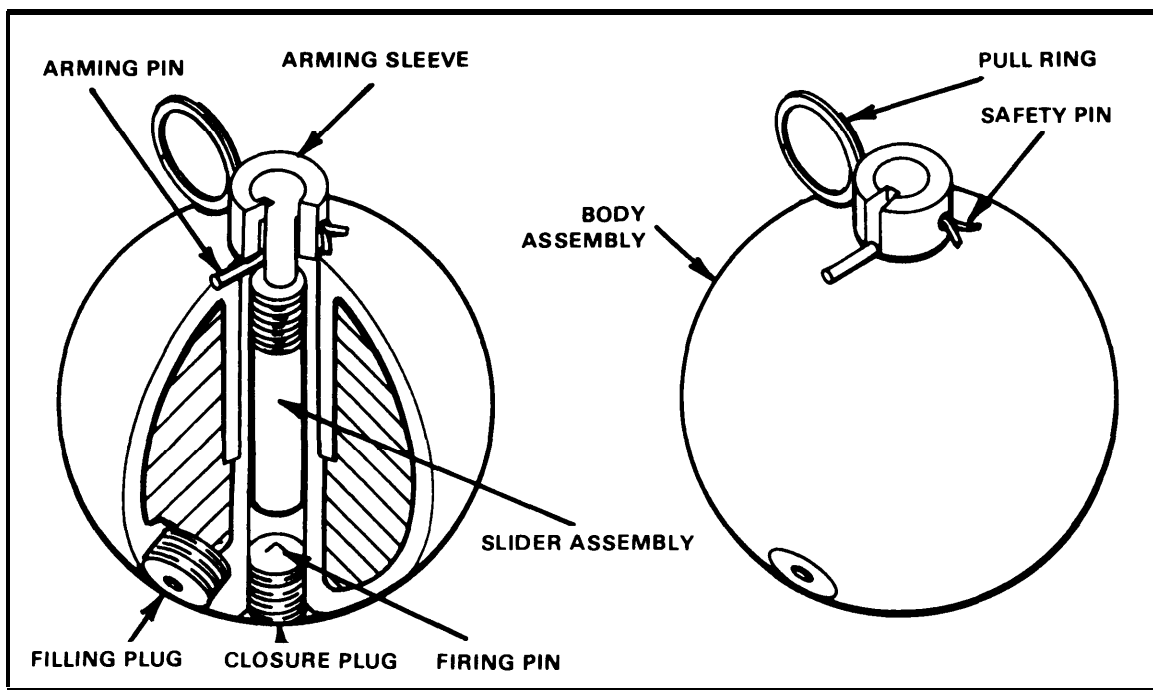

Figure D-8. The ABC-M25A1 riot control hand grenade.

**WARNING** WHEN THE ABC M25A1 GRENADE IS EMPLOYED, DO NOT DROP IT BECAUSE IT MAY GO OFF IMMEDIATELY. DO NOT ATTEMPT TO REPLACE A PULLED SAFETY PIN, AND DO NOT RELAX THUMB PRESSURE ON THE ARMING SLEEVE AFTER THE SAFETY PIN IS PULLED.

- a. Body. Compressed fiber or plastic sphere.
- b. Filler. The fillers of the M25-series of riot control hand grenades vary in weight and composition according to

the type of agent contained in the grenade. All fillers are mixed with silica aerogel for increased dissemination efficiency.

c. Fuze. Integral.

d. Weight. 7.5 to 8 ounces, depending on the type of filler.

e. Capabilities. The average soldier can throw the grenade 50 meters. The M25-series of riot control hand grenades have a radius burst (visible cloud agent) of approximately 5 meters, but fragments of the grenade are occasionally projected 25 meters.

f. Color and Markings. Same as the M6 and M6A1 grenades (paragraph D-7f). (Most grenades of the M25-series currently in use are not painted according to any color-coding system. They are either totally unpainted or have only a red band and red markings.)

**WARNING: FRIENDLY FORCES SHOULD DON PROTECTIVE MASKS BEFORE USING THESE GRENADES**

#### D-9. M34 WHITE PHOSPHOROUS HAND GRENADE

The M34 chemical smoke grenade is the most versatile of all hand grenades (Figure D-9). The grenade can be used for signaling, screening, or incendiary missions, or for producing casualties. The use of this grenade also has a psychological impact on the enemy.

a. Body. Rolled steel (serrated to facilitate fragmentation).

b. Roller. 15 ounces of white phosphorous.

c. Fuze. M206A2.

d. Weight. 27 ounces.

e. Capabilities. The average soldier can throw the grenade 30 meters. The grenade has a bursting radius of 35 meters. All friendly personnel within this 35-meter area should be in a covered position to avoid being struck by burning particles. The WP filler burns for approximately 60 seconds at a temperature of 5,000 degrees Fahrenheit. This intense heat causes the smoke produced by the grenade to rise quite rapidly, especially in cool climates, making the M34 grenade less desirable for use as a screening



agent. (The M15 WP smoke hand grenade is similar to the M34. For more information, refer to TM 9-1330-200-12.)

f. Color/Markings. Under the old ammunition color-coding system, the white phosphorous grenade is light gray with a single yellow band and yellow markings. Under the new standard color-coding system, the M34 grenade is light green with a single yellow band and light red markings.

NOTE: Most M34 WP smoke hand grenades presently in use were manufactured prior to the standard color-coding system agreement and are painted according to the old color code.

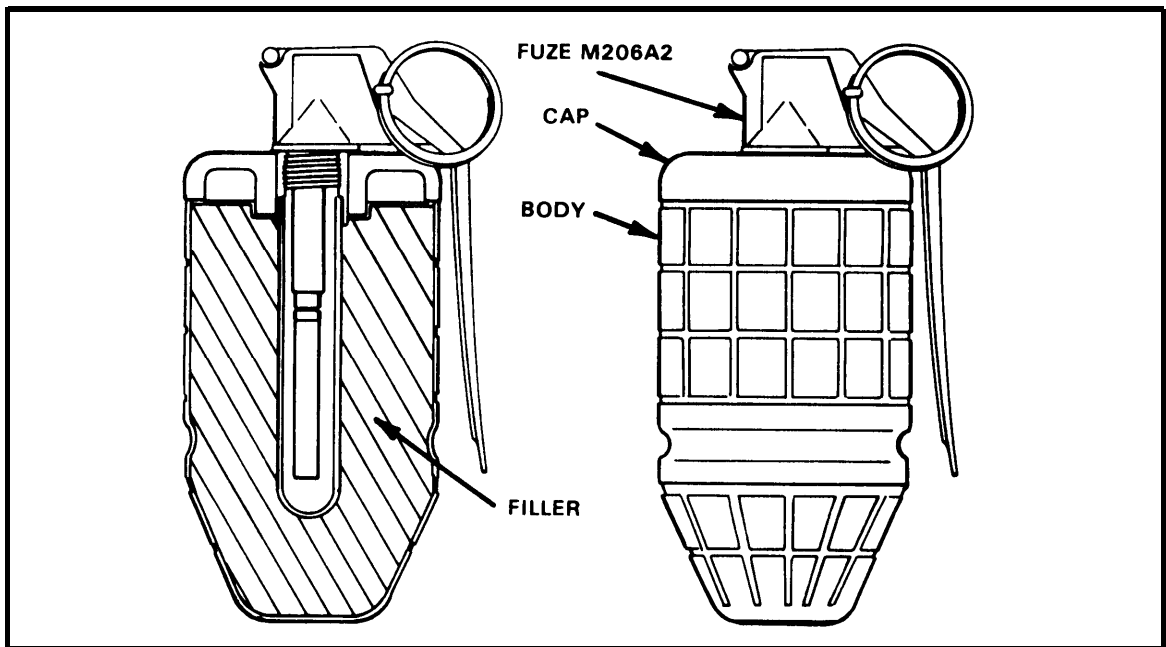
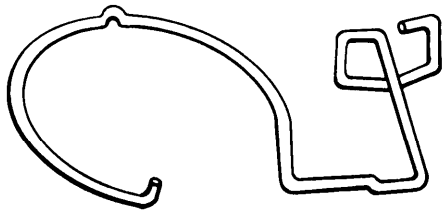

Figure D-9. M34 WP smoke hand grenade.

**WARNING** THE M34 HAS A BURSTING RADIUS OF 35 METERS WHICH IS FARTHER THAN THE AVERAGE SOLDIER CAN THROW IT THEREFORE THE THROWER MUST BE IN A COVERED OR PROTECTED POSITION

#### D-10. SAFETY CLIPS

Improvements have also been made in safety clips. There are four types of safety clips that might be encountered on the obsolete grenades (Figure D-10).



**SAFETY CLIP FOR USE ON  
GRENADE M61 AND M62**

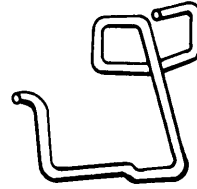

**SAFETY CLIP FOR USE ON  
GRENADE M67 AND XM69**

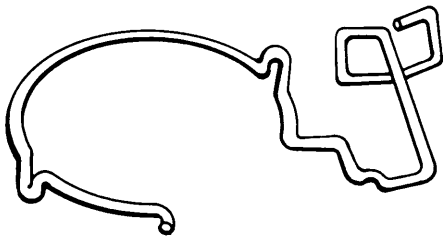

**SAFETY CLIP FOR USE ON  
GRENADE M68**

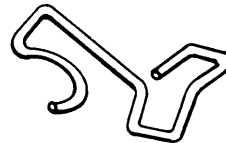

**SAFETY CLIP FOR USE ON  
GRENADE M67**

Figure D-10. Safety clips on obsolete grenades.

APPENDIX E

RANGE CONSTRUCTION/MODIFICATION

This appendix provides structural dimensions and safety requirements for the construction/modification of a hand grenade range.

E-1. STRUCTURAL DIMENSIONS

The structural dimensions of throwing pits will be in accordance with Chapter 4, with a separation distance of 25 meters between them. This will place adjacent pits outside the effective casualty-producing radius of 15 meters for the M67 fragmentation grenade. A rear wall (knee wall) will be constructed no more than 0.6 meter (2 feet) high and 0.15 meter (6 inches) thick. It will extend the width of the throwing pit, connecting both ends of the enclosure. The top of the knee wall should be sloped inward to allow any grenade dropped on the wall to roll into the throwing pit. Drain pipes, no more than 2 inches in diameter, will be installed in the knee wall, to allow throwing pit drainage. The floor of the throwing pits should be sloped in the direction of the drainage pipes. Grenade sumps/ditches will not be constructed inside the throwing pits. (See Figure E-1.)

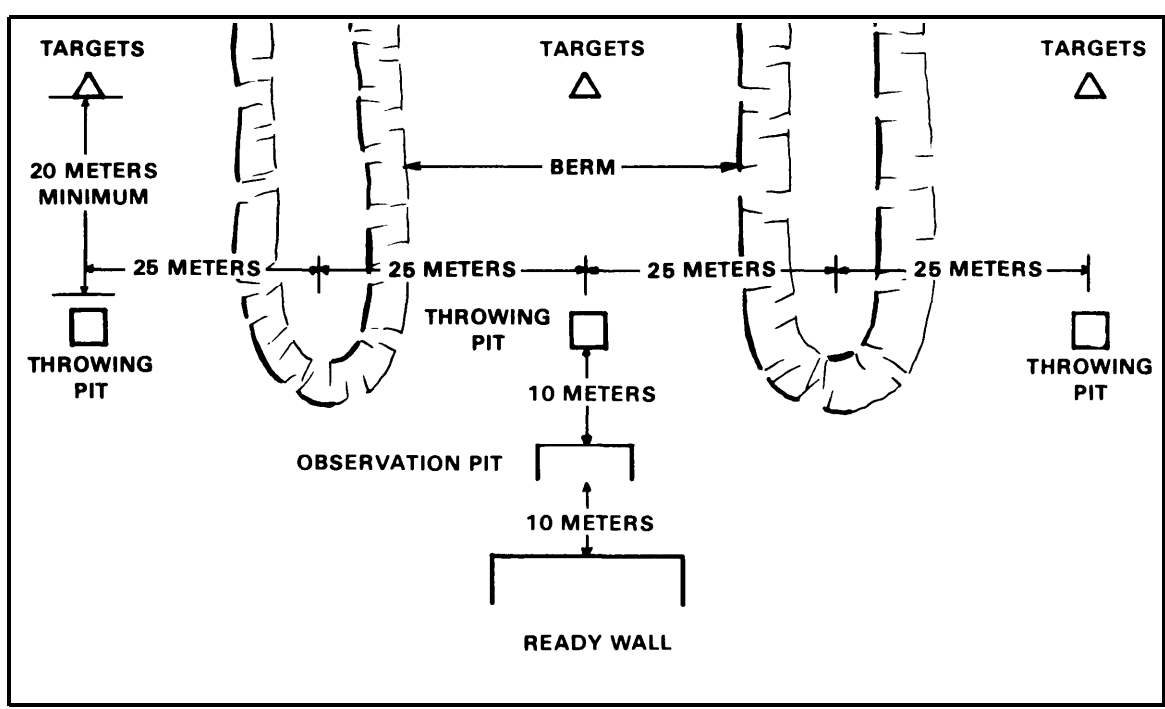

Figure E-1. Range layout.

#### E-2. SAND/SAWDUST PIT AND THROWING PIT

A sand/sawdust pit will be placed outside the knee wall to cushion the fall of personnel diving over the wall in the event a grenade is dropped in the throwing pit. (See Figure E-2.)

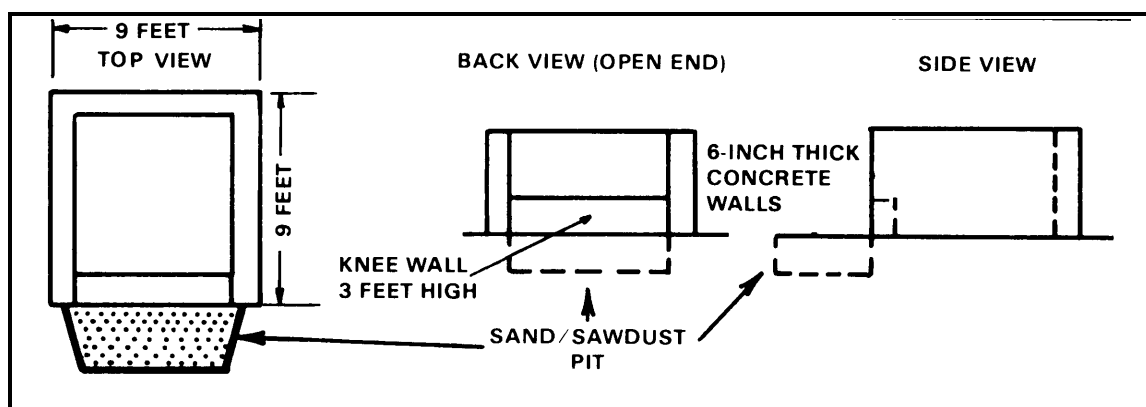

Figure E-2. Sand/sawdust pit and throwing pit.

#### E-3. PIT SEPARATIONS

Where possible, throwing pits should be separated by steel/concrete/wooden revetments or earthen berms of a length and height to lessen the effect of high velocity/low angle fragments; for example, 50 meters long and 1.8 meters high. The thickness will vary according to the type of construction. This would permit grenade throwing to continue from adjacent pits when a dud grenade occurs, requiring closure of a specific pit pending dud disposal.

#### E-4. OBSERVATION PITS

Observation pits will be built of a sufficient height to enable the OIC to better observe and control all throwing pits. Laminated window panes, constructed as described below, provide the necessary degree of safety for observation pits.

10-millimeter glass (outside)
7-millimeter polycarbonate resin sheet
6-millimeter glass
6-millimeter polycarbonate resin sheet
<u>6-millimeter glass</u>
Total: 35 millimeters (approximately 1 3/8 inches)

## APPENDIX F

## NATO HAND GRENADES

This appendix provides general information on NATO hand grenade identification, functions, and capabilities. The North Atlantic Treaty Organization nations have an extensive inventory of grenades. This appendix describes only the more common grenades that the United States soldier might encounter during joint operations.

## Section I. NETHERLANDS

## F-1. NR17

Type: fragmentation, offensive.

Weight: 475 grams.

Length: 125 millimeters.

Diameter: 56 millimeters.

Body Material: plastic.

Filler Weight: 205 grams.

Filler Material: high explosive.

Fuze Type: pyrotechnic delay.

Fuze Delay: 5 seconds.

Range Thrown: 30 to 40 meters.

Effective Radius: 5 meters.

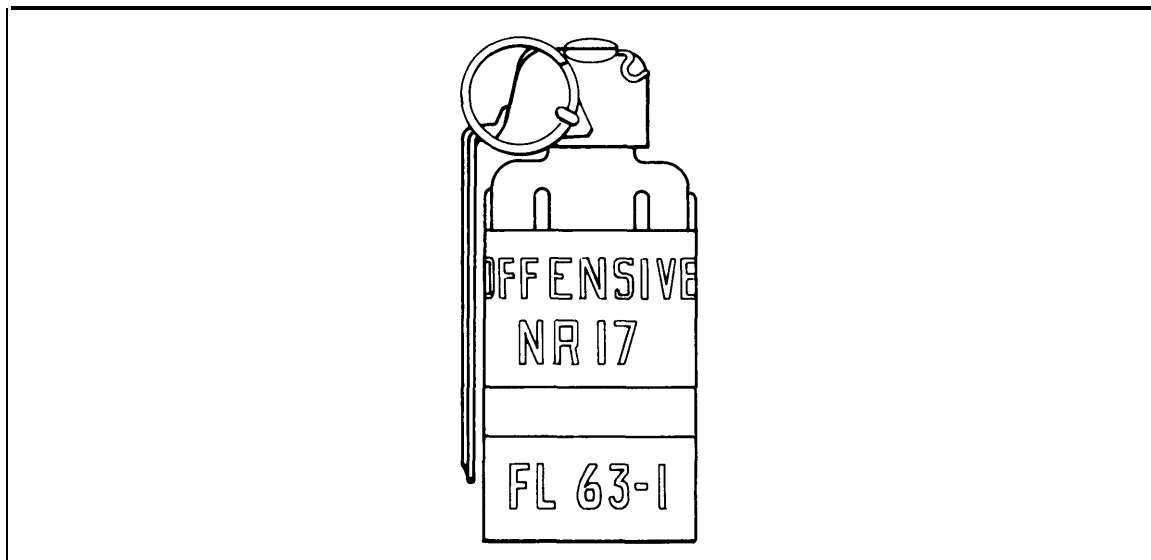

Figure F-1. NR17.

F-2. NR13C1

Type: fragmentation, offensive.

Weight: 475 grams.

Length: 143 millimeters.

Diameter: 54 millimeters.

Body Material: steel.

Filler Weight: 225 grams.

Filler Material: high explosive.

Fuze Type: pyrotechnic delay.

Fuze Delay: 5 seconds.

Range Thrown: 30 meters.



Figure F-2. NR13C1.

F-3. MARK 2

Type: fragmentation.

Weight: 630 grams.

Length: 114 millimeters.

Diameter: 57 millimeters.

Body Material: cast iron.

Filler Weight: 55 grams.

Filler Material: TNT powdered.

Fuze Type: pyrotechnic delay.

Fuze Delay: 3 seconds.

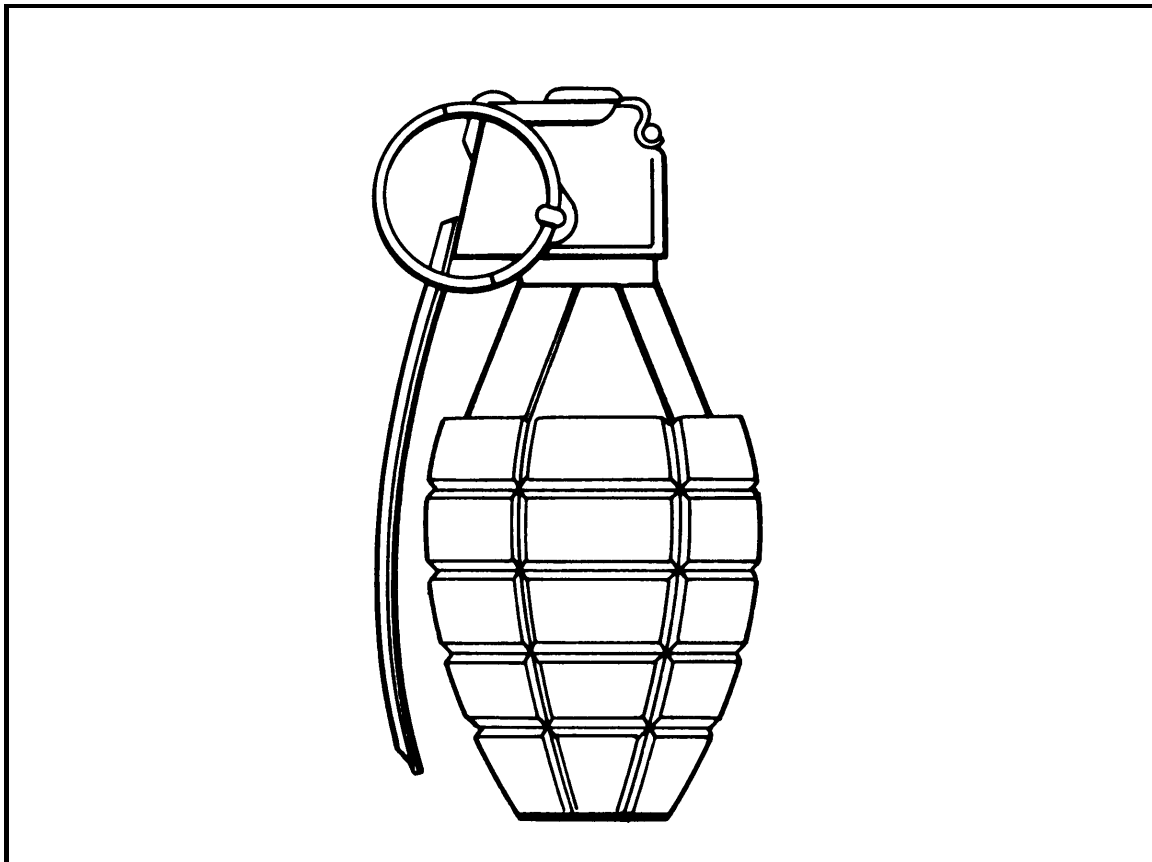

Figure F-3. Mark 2.

F-4. NR1C1

Type: fragmentation.

Weight: 60 grams.

Length: 122 millimeters.

Diameter: 56 millimeters.

Body Material: cast iron.

Filler Weight: 55 grams.

Filler Material: TNT powdered.

Fuze Type: pyrotechnic delay.

Fuze Delay: 3 seconds

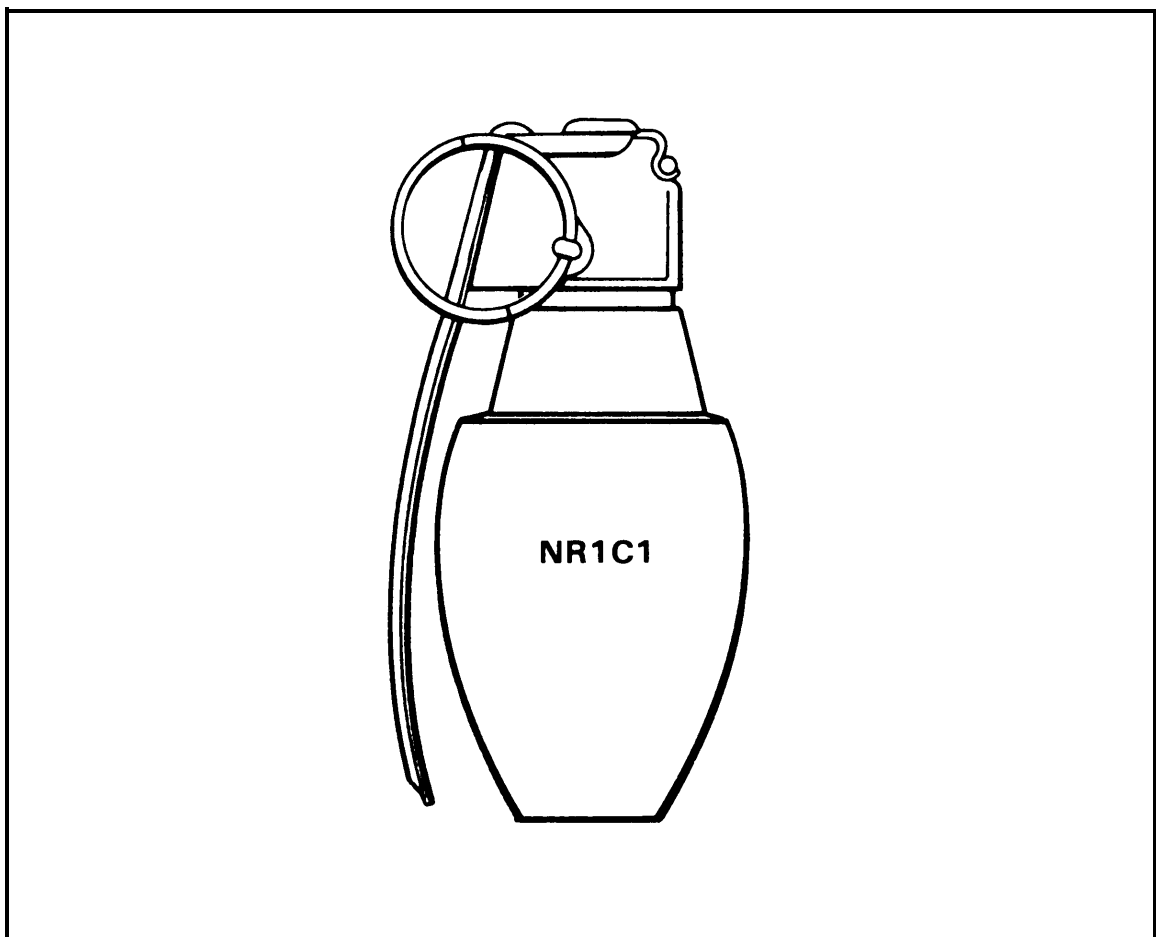

Figure F-4. NR1C1.



F-5. JNS 62-65

Type: smoke.

Weight: 660 grams.

Length: 151 millimeters.

Diameter: 63 millimeters.

Body Material: tinned steel.

Filler Weight: 405 grams.

Filler Material: colored smoke.

Fuze Type: delay

Fuze Delay: 2 to 3 seconds.

Burn Time: 1 to 2 minutes.

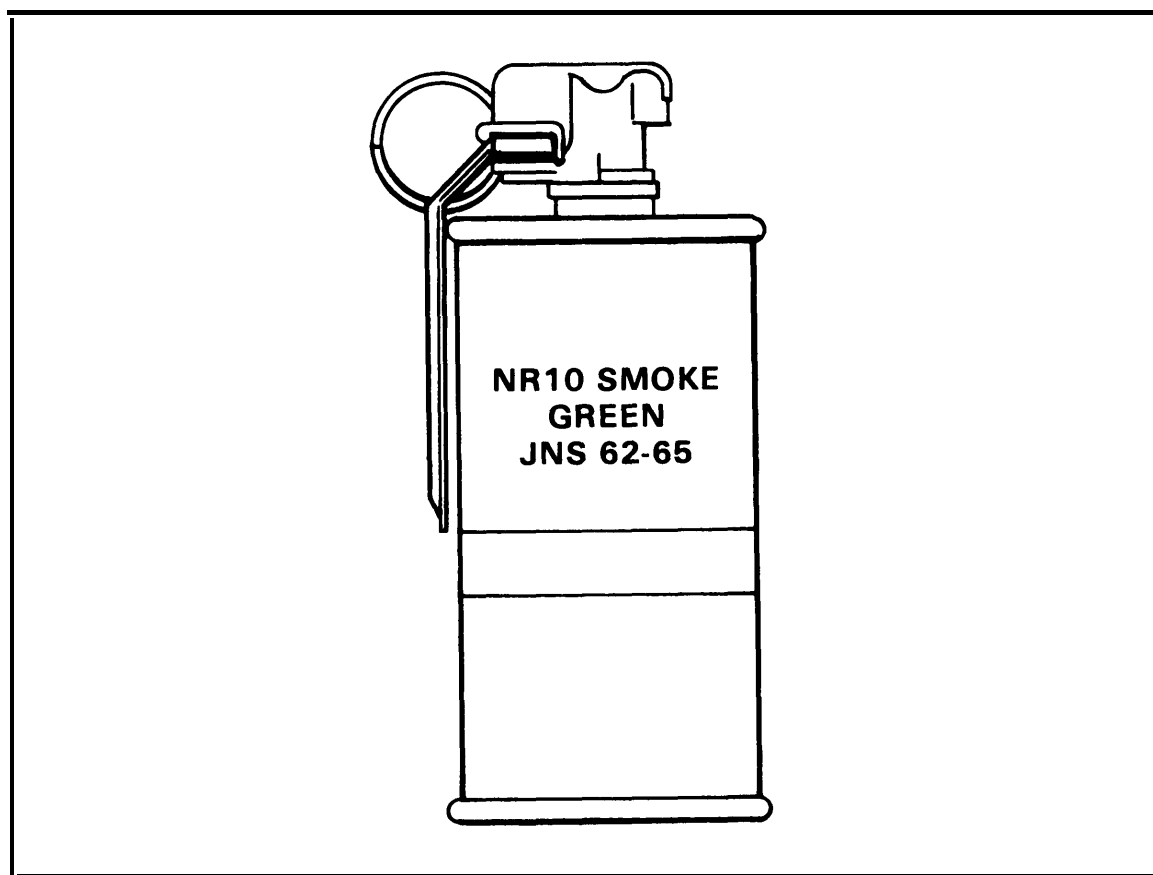

Figure F-5. JNS 62-65.

F-6. NR12

Type: incendiary

Weight: 735 grams

Length: 153 millimeters.

Diameter: 63 millimeters.

Body Material: tinned steel.

Filler Material: thermite.

Fuze Type: delay.

Fuze Delay: 2 seconds.

Range Thrown: 40 meters.

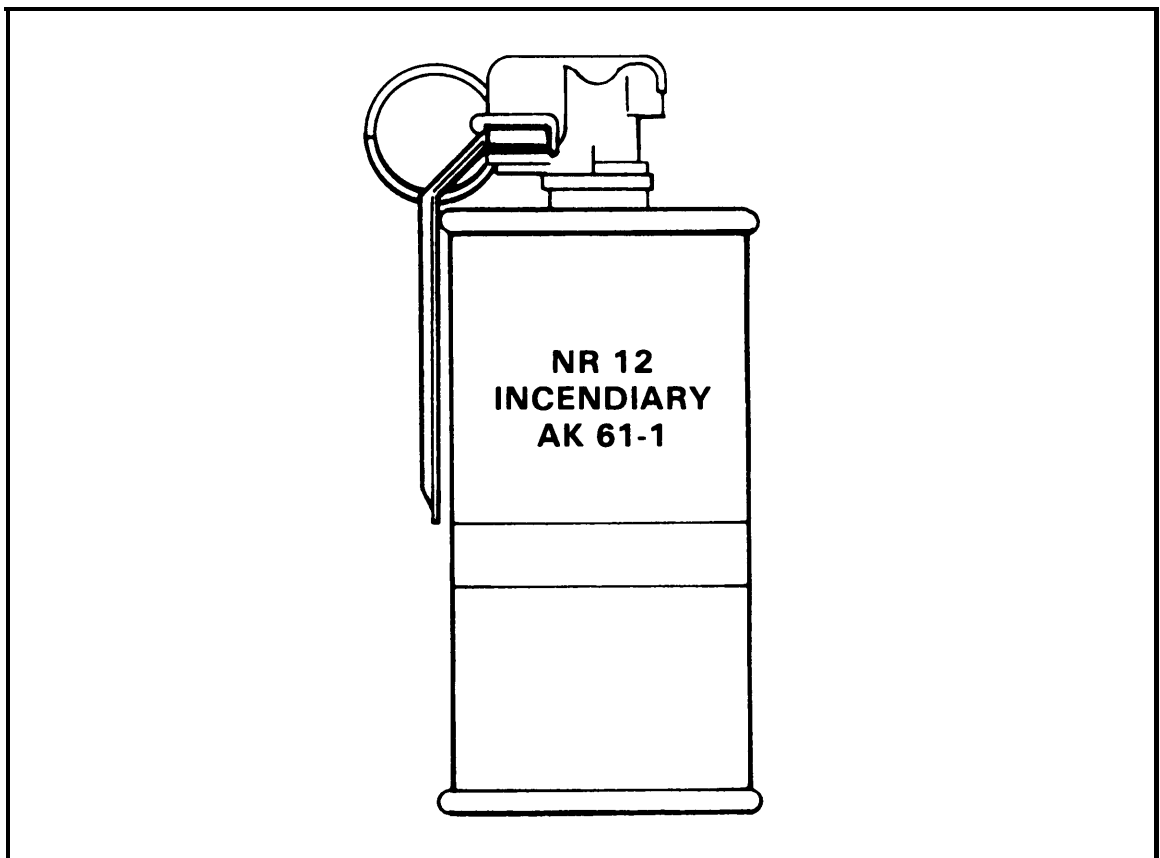

Figure F-6. NR12.

F-7. NR16

Type: smoke.

Weight: 284 grams.

Length: 101 millimeters.

Diameter: 50 millimeters.

Body Material: tinned steel.

Filler Weight: 180 grams.

Filler Material: white phosphorus.

Fuze Type: delay.

Fuze Delay: 4 seconds.

Range Thrown: 37 meters.



Figure F-7. NR16.

F-8. NR20C1

Type: fragmentation.

Weight: 380 grams.

Length: 104.5 millimeters.

Diameter: 62 millimeters.

Body Material: plastic.

Filler Weight: 145 grams.

Filler Material: composition B.

Fuze Type: 19C3 delay.

Fuze Delay: 3.5 seconds  $\pm$  0.5 second.

Effective Radius: 15 meters.



Figure F-8. NR20C1.

Section II. GERMANY

F-9. DM 24/68

Type: incendiary smoke.

Weight: 340 grams.

Length: 133 millimeters.

Diameter: 67 millimeters.

Body Material: plastic.

Filler Weight: 255 grams.

Filler Material: red phosphorus.

Fuze Type: impact.

Fuze Delay: none.

Burn Time: 5 minutes.

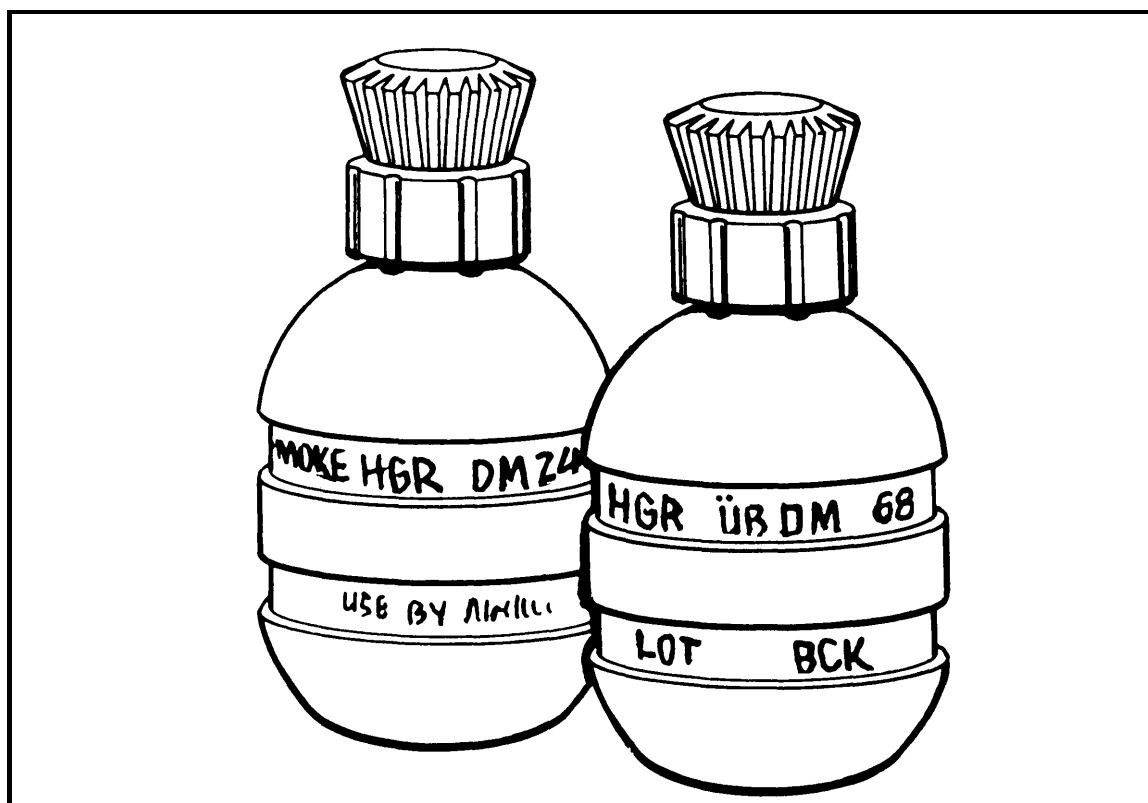

Figure F-9. DM 24/68.

F-10. HC DM 15

Type: smoke.

Weight: 1,200 grams.

Length: 175 millimeters.

Diameter: 76 millimeters.

Body Material: metal.

Filler Weight: 880 grams.

Filler Material: hexachlorethane.

Fuze Type: mechanical ignition.

Fuze Delay: 2.5 seconds after ignition.

Burn Time: 2.5 minutes.

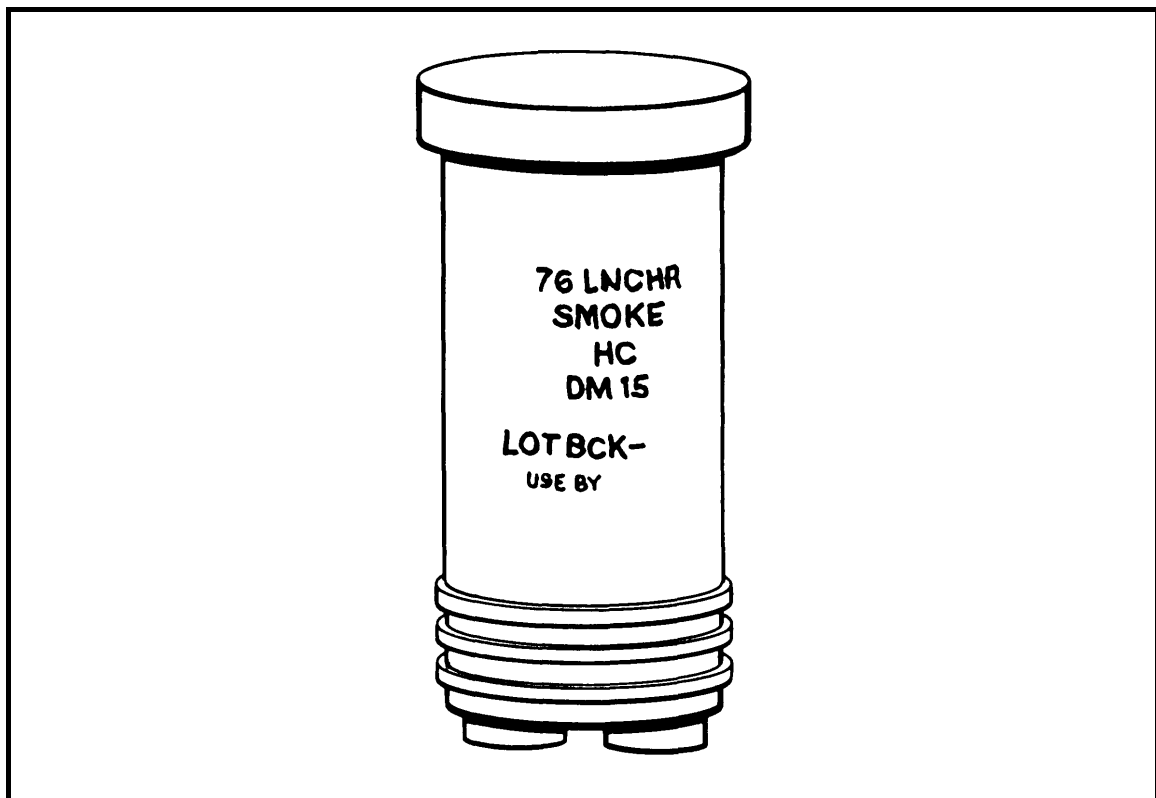

Figure F-10. HC DM 15.

F-11. M-DN 11

Type: fragmentation, defensive.

Weight: 470 grams.

Body Material: plastic.

Filler Weight: 42.5 grams.

Filler Material: plasticised nitropenta.

Fuze Type: delay.

Fuze Delay: 4 seconds.

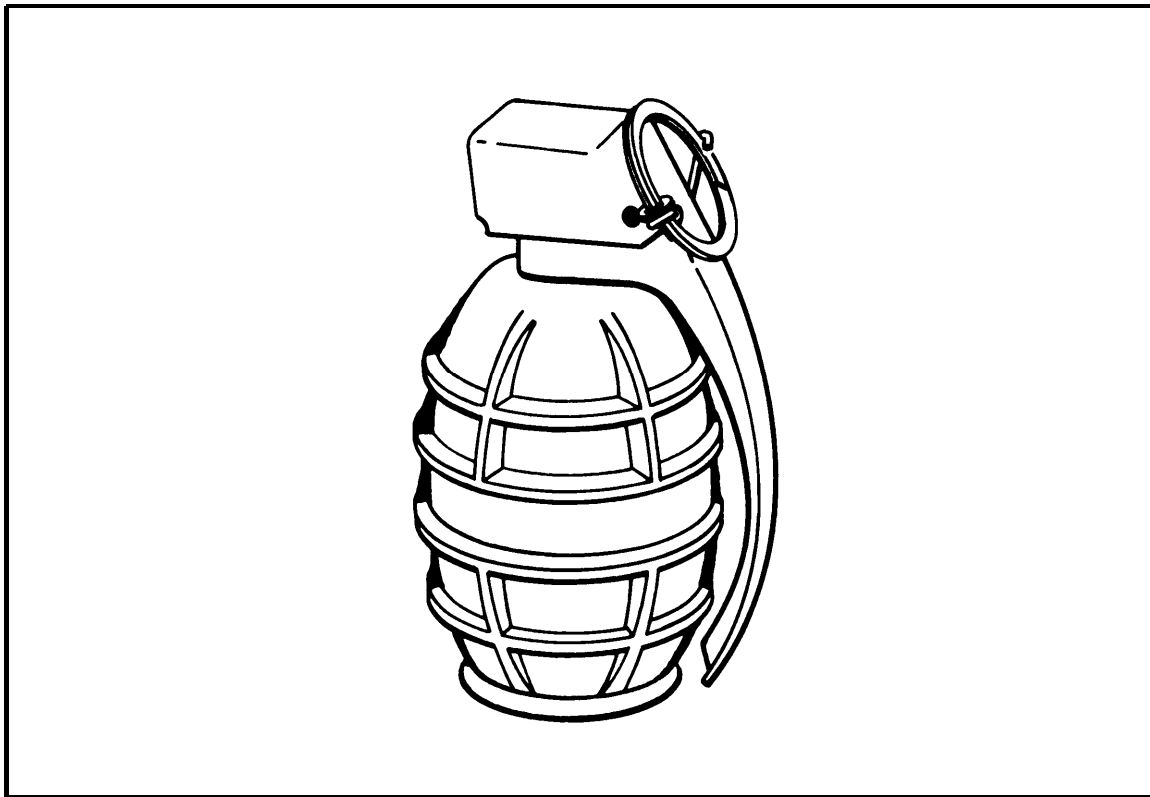

Figure F-11. M-DN 11.

Section III. BELGIUM

F-12. 35X65 MECAR

Type: fragmentation, defensive.

Weight: 230 grams.

Length: 88 millimeters.

Diameter: 35 millimeters.

Body Material: metal.

Filler Weight: 73 grams.

Filler Material: composition B.

Fuze Type: delay.

Fuze Delay: 4 seconds.

Range Thrown: 40 meters.

Effective Radius: 10 meters.

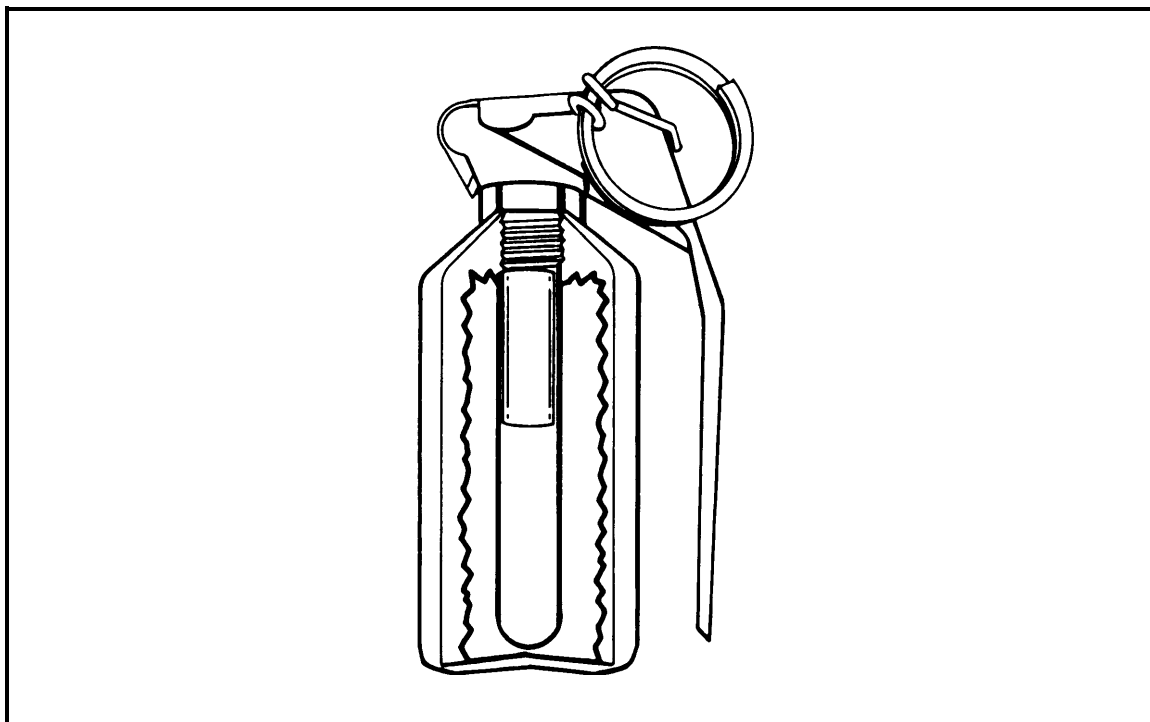

Figure F-12. 35X65 MECAR.



Section IV. UNITED KINGDOM

F-13. 36M

Type: antipersonnel.

Weight: 962 grams.

Length: 84 millimeters.

Diameter: 60 millimeters.

Body Material: cast iron.

Filler Weight: 774 grams.

Filler Material: TNT.

Fuze Type: delay.

Fuze Delay: 7 seconds.

Range Thrown: 25 meters.

Effective Radius: 10 meters.

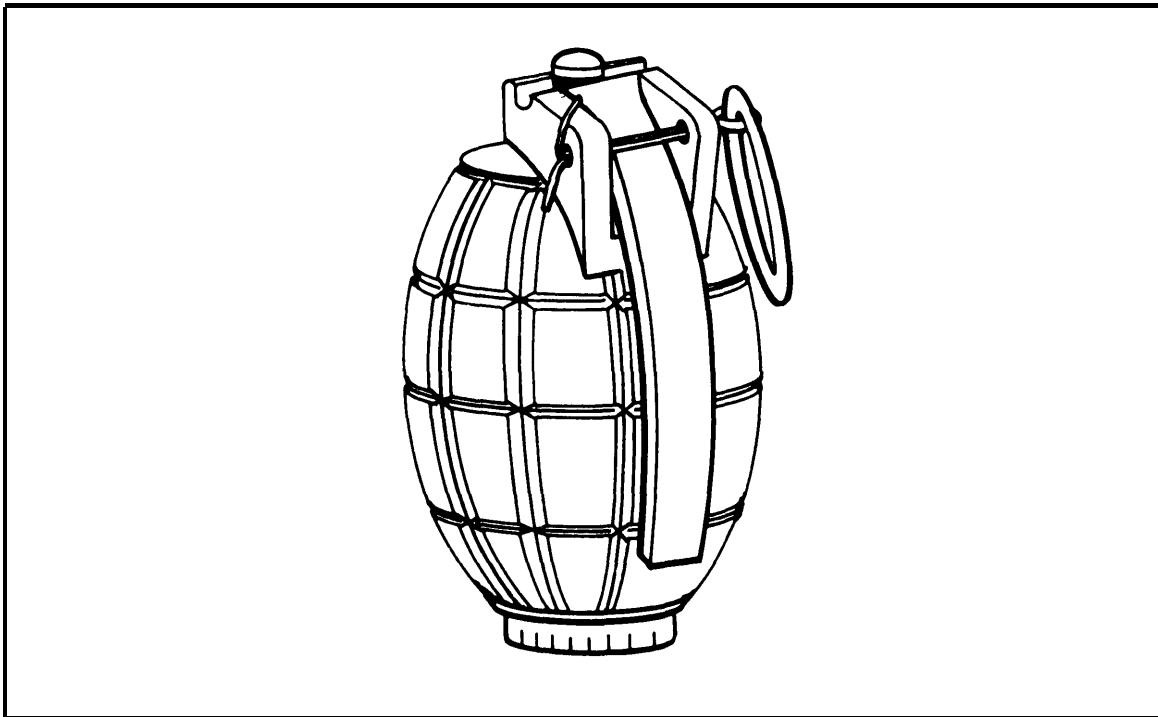

Figure F-13. 36M.

F-14. 80 WP MARK 1

Type: combat.

Weight: 485 grams.

Length: 136 millimeters.

Diameter: 65 millimeters.

Body Material: tinned plate.

Filler Weight: 11 1/4 ounces.

Filler Material: white phosphorus.

Fuze Type: 75 Mark 2 detonator.

Fuze Delay: 2.5 to 4 seconds.

Range Thrown: 15 to 20 meters.

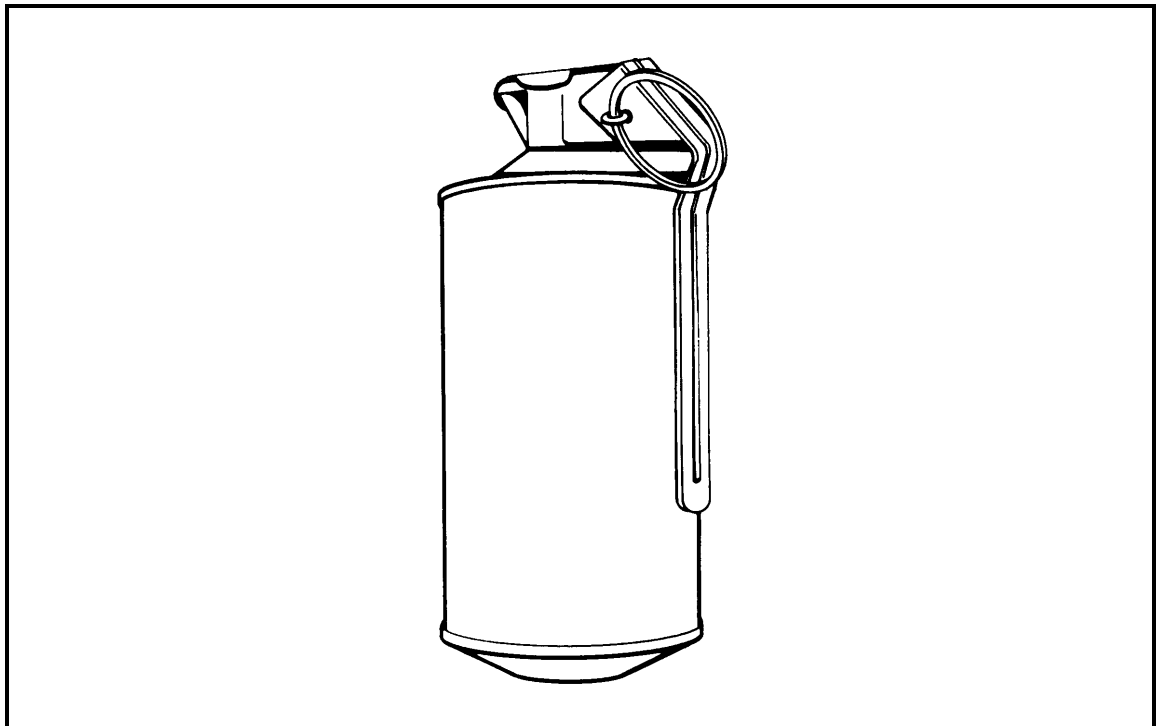

Figure F-14. 80 WP Mark 1.

F-15. PC1

Type: practice.

Weight: 265 grams.

Length: 95 millimeters.

Diameter: 56 millimeters.

Body Material: soft plastic.

Filler Weight: 80 grams.

Filler Material: white powder.

Fuze Type: delay.

Fuze Delay: 4.4 seconds  $\pm$  0.5 second.

Range Thrown: 40 meters.

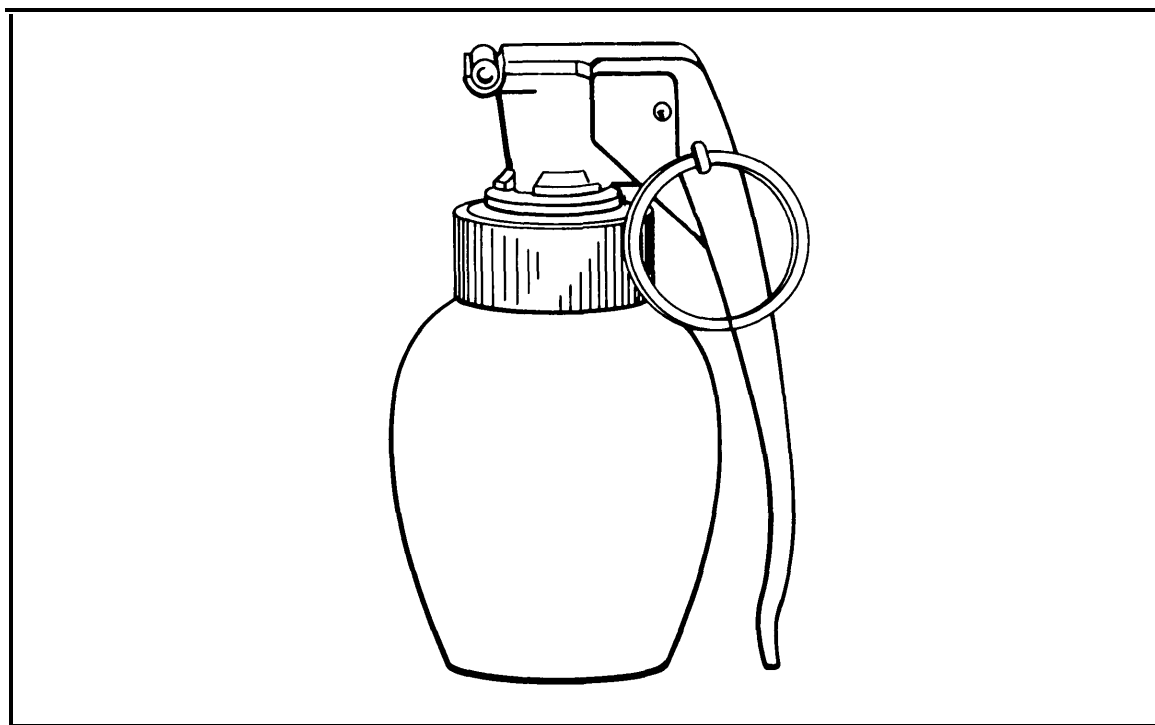

Figure F-15. PC1 practice grenade.

F-16. L2A2

Type: antipersonnel.

Weight: 395 grams.

Length: 84 millimeters.

Diameter: 60 millimeters.

Body Material: thin sheet metal.

Filler Weight: 170 grams.

Filler Material: RDX/TNT.

Fuze Type: L25A6.

Fuze Delay: 4.4 seconds  $\pm$  0.5 second.

Range Thrown: 40 meters.

Effective Radius: 10 meters.

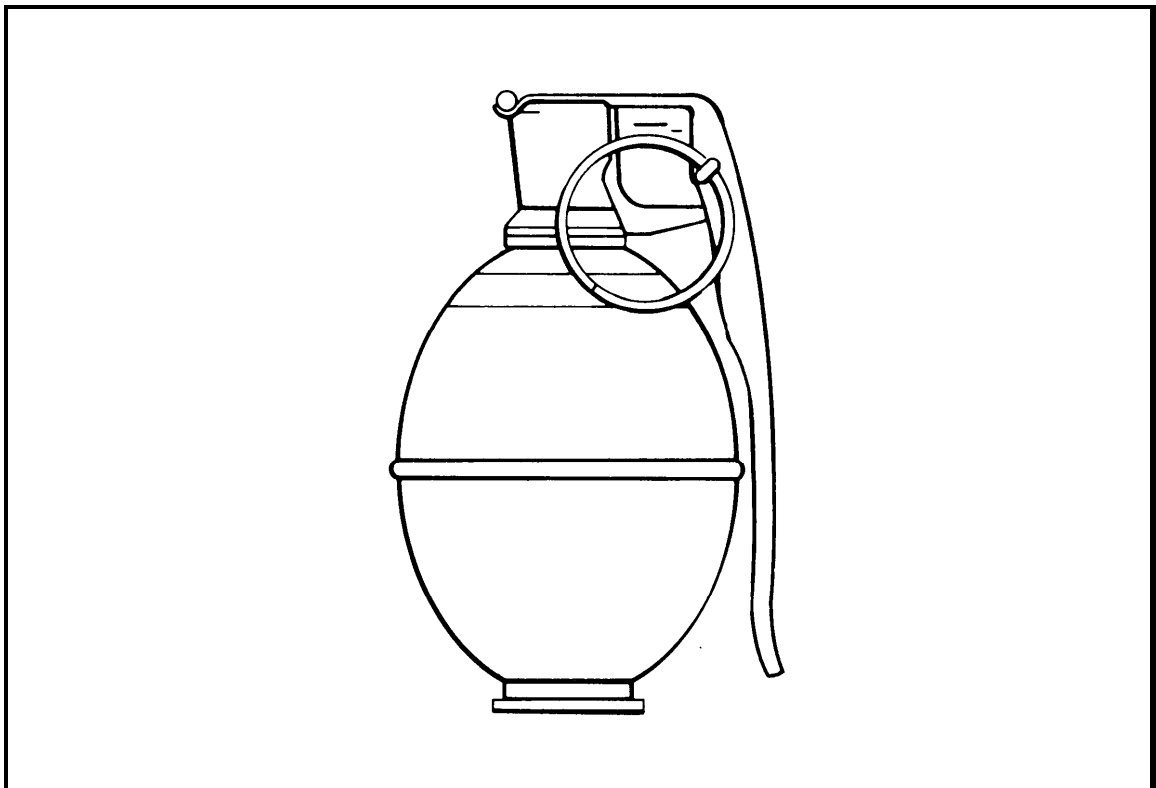

Figure F-16. L2A2.

F-17. CS 83

Type: riot control.

Weight: 445 grams.

Length: 135 millimeters.

Diameter: 60 millimeters.

Body Material: tin.

Filler Weight: 320 grams.

Filler Material: CS, gas.

Fuze Type: delay.

Fuze Delay: 2 to 4 seconds.

Range Thrown: 20 to 30 meters.

Burn Time: 20 to 25 seconds.

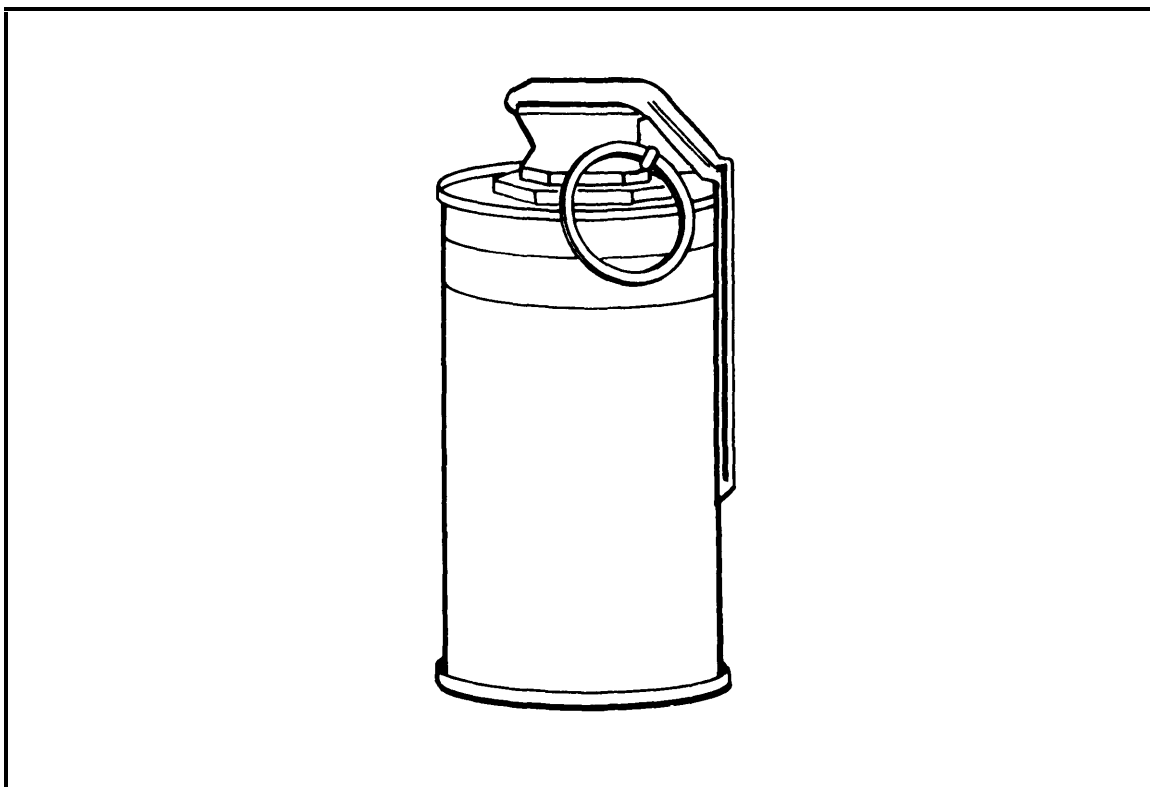

Figure F-17. CS 83.

F-18. RUBBER BURSTING CS

Type: riot control.

Weight: 630 grams.

Length: 175 millimeters.

Diameter: 60 millimeters.

Body Material: rubber.

Filler Weight: 480 grams.

Filler Material: CS pellets.

Fuze Type: short delay.

Fuze Delay: 2 to 4 seconds.

Range Thrown: 25 to 35 meters.

Burn Time: 20 to 25 seconds.

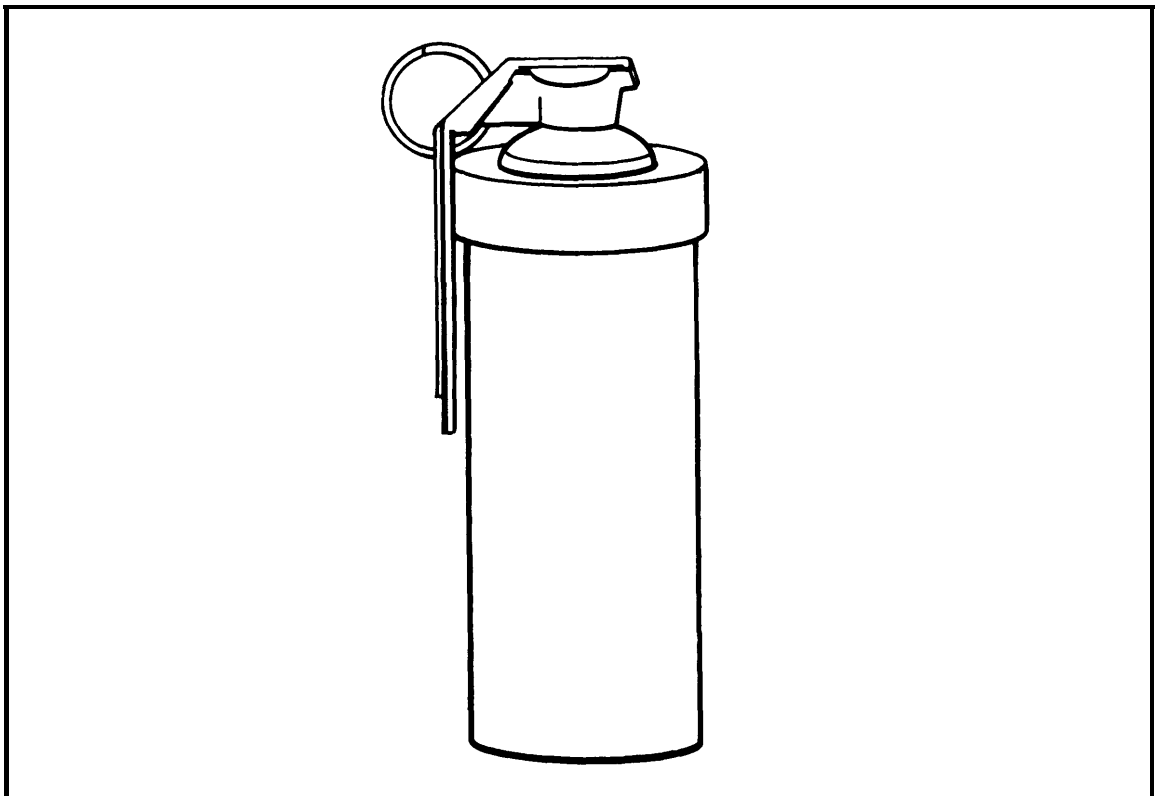

Figure F-18. Rubber bursting CS grenade.

Section V. AUSTRIA

F-19. ARGES HG 77

Type: fragmentation.

Weight: 480 grams.

Length: 96 millimeters.

Diameter: 65 millimeters.

Body Material: rigid plastic.

Filler Weight: 70 grams.

Filler Material: high explosive.

Fuze Type: delay.

Fuze Delay: 4 to 5 seconds.

Range Thrown: 45 meters.

Effective Radius: 10 meters.

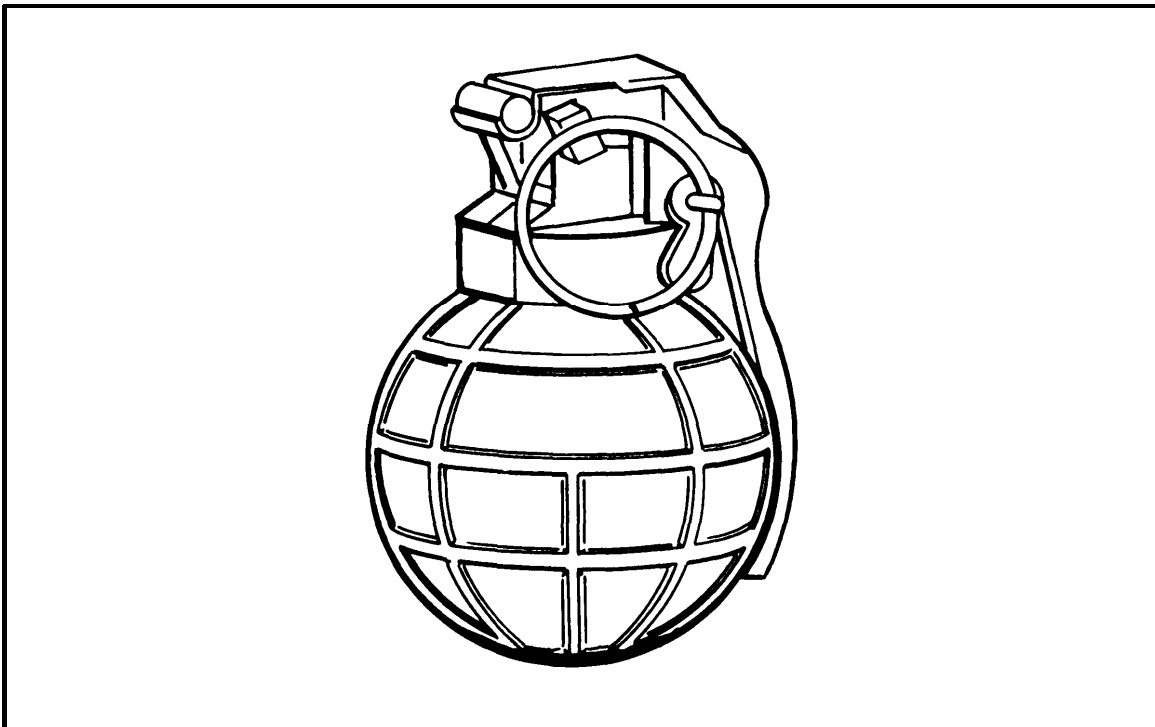

Figure F-19. Arges HG 77.

F-20. ARGES HG 78

Type: fragmentation (offensive and defensive).

Weight: 520 grams.

Length: 115 millimeters.

Diameter: 60 millimeters.

Body Material: plastic with steel core.

Filler Weight: 7 ounces.

Filler Material: high explosive.

Fuze Type: delay.

Fuze Delay: 4 seconds.

Range Thrown: 35 to 40 meters.

Effective Radius: 15 meters.

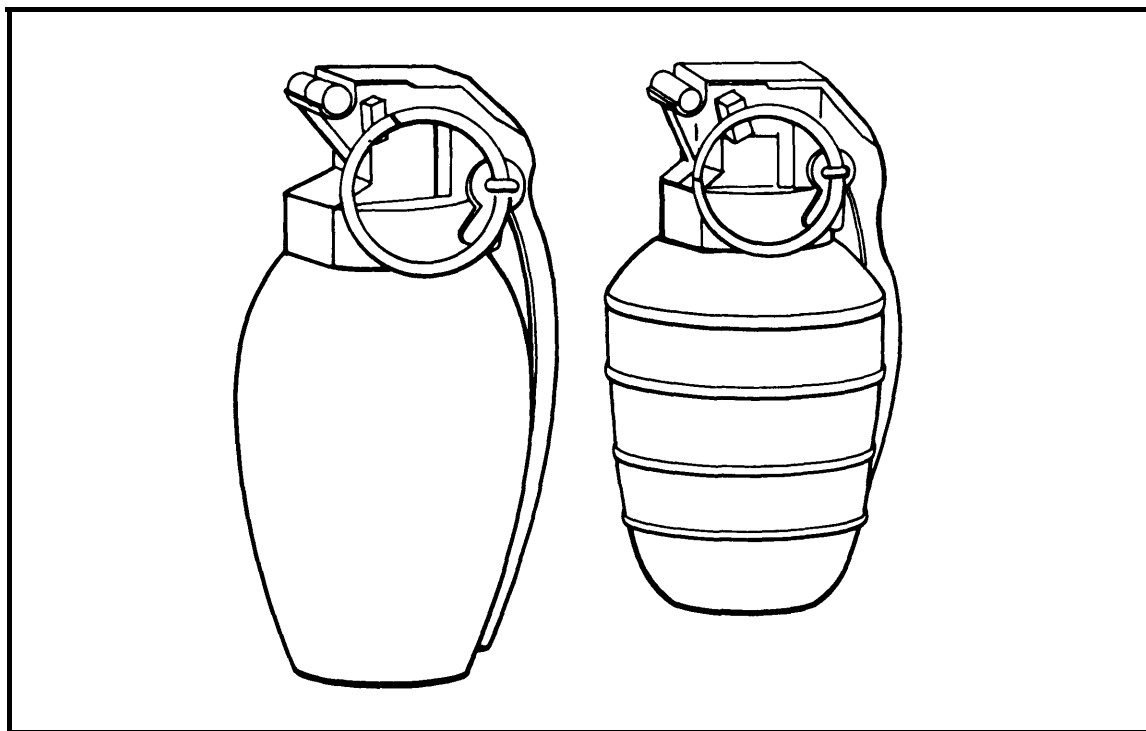

Figure F-20. Argos HG 78.



F-21. ARGES HG 79

Type: fragmentation.

Weight: 360 grams.

Length: 95 millimeters.

Diameter: 58 millimeters.

Body Material: plastic.

Filler Weight: 40 grams.

Filler Material: high explosive.

Fuze Type: delay.

Fuze Delay: 4 to 5 seconds.

Range Thrown: 45 meters.

Effective Radius: 10 meters.

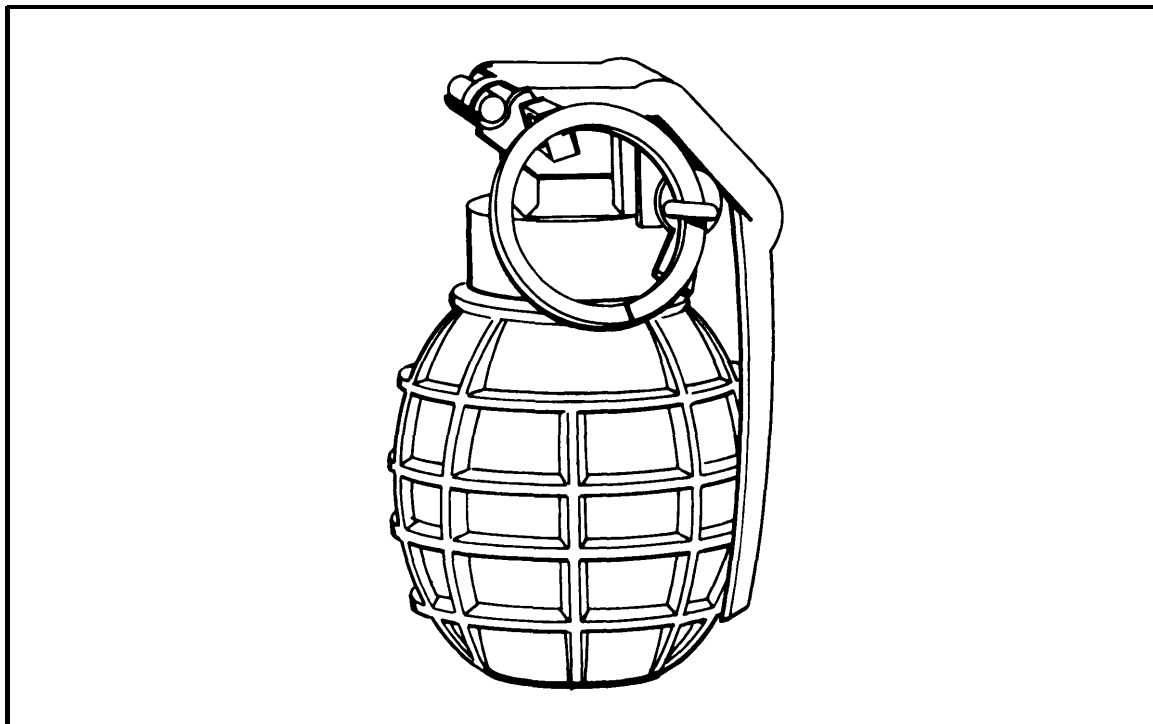

Figure F-21. HG 79.

F-22. ARGES HG 84

Type: fragmentation.

Weight: 480 ± 20 grams.

Length: 115 ± 2 millimeters.

Diameter: 60 ± 1 millimeters.

Body Material: plastic.

Filler Weight: 93 ± 3 grams.

Filler Material: high explosive.

Fuze Type: delay.

Fuze Delay: 4 seconds nominal.

Range Thrown: 35 to 40 meters.

Effective Radius: 15 meters.

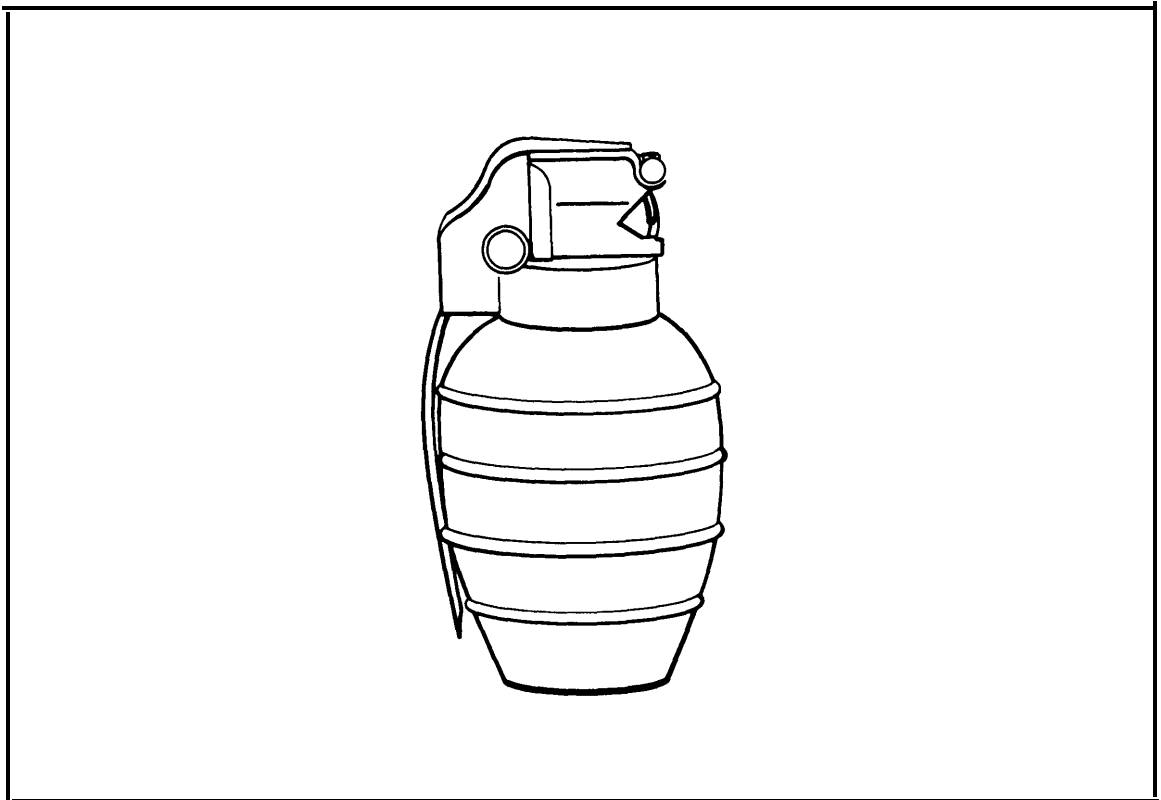

Figure F-22. Arges HG 84.

F-23. TYPE 72

Type: fragmentation.

Weight:  $485 \pm 30$  grams.

Length:  $115 \pm 2$  millimeters.

Diameter:  $60 \pm 1$  millimeters.

Body Material: rigid plastic.

Filler Weight:  $65 \pm 5$  grams.

Filler Material: high explosive.

Fuze Type: delay.

Fuze Delay:  $4 \pm 1.5$  seconds.

Range Thrown: 40 meters.

Effective Radius: 20 meters.

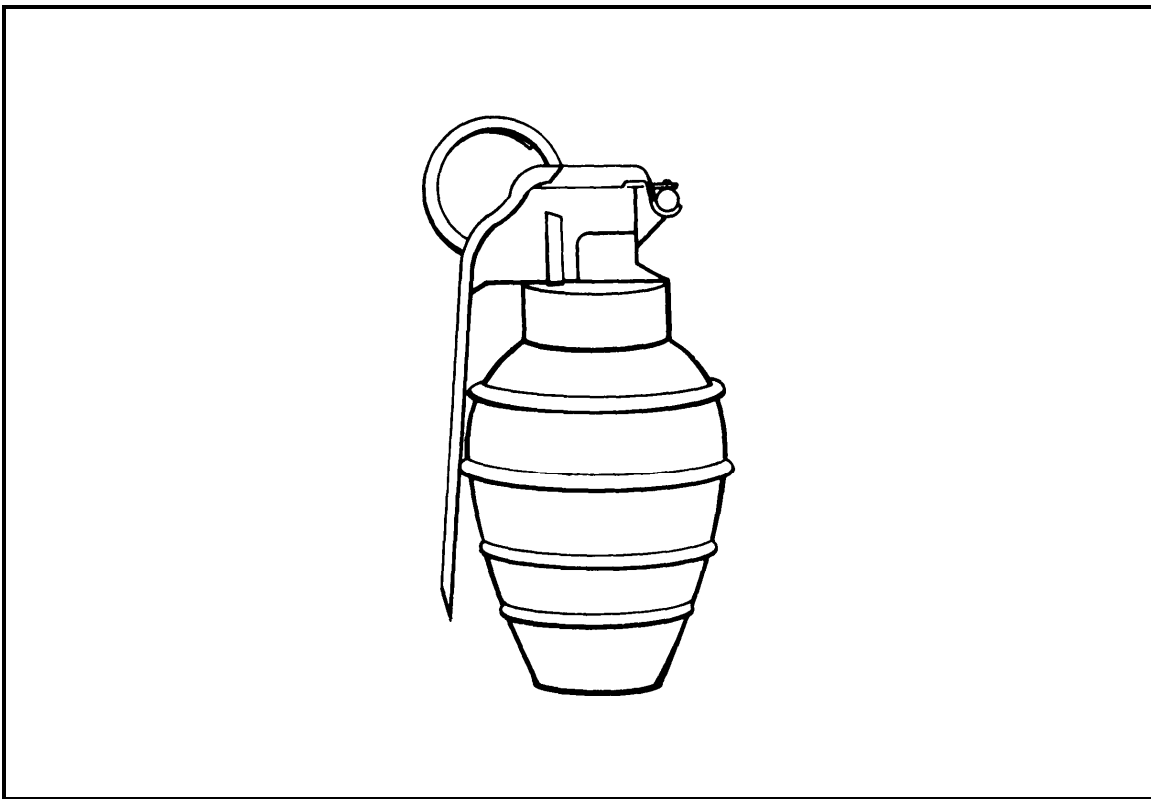

Figure F-23. Type 72.

F-24. TYPE 73

Type: fragmentation.

Weight:  $355 \pm 20$  grams.

Length:  $91 \pm 2$  millimeters.

Diameter:  $57 \pm 1$  millimeters.

Body Material: plastic.

Filler Weight:  $37 \pm 20$  grams.

Filler Material: high explosive.

Fuze Type: delay.

Fuze Delay:  $4 + 1.5 - 0.5$  seconds.

Range Thrown: 45 meters.

Effective Radius: 15 meters.

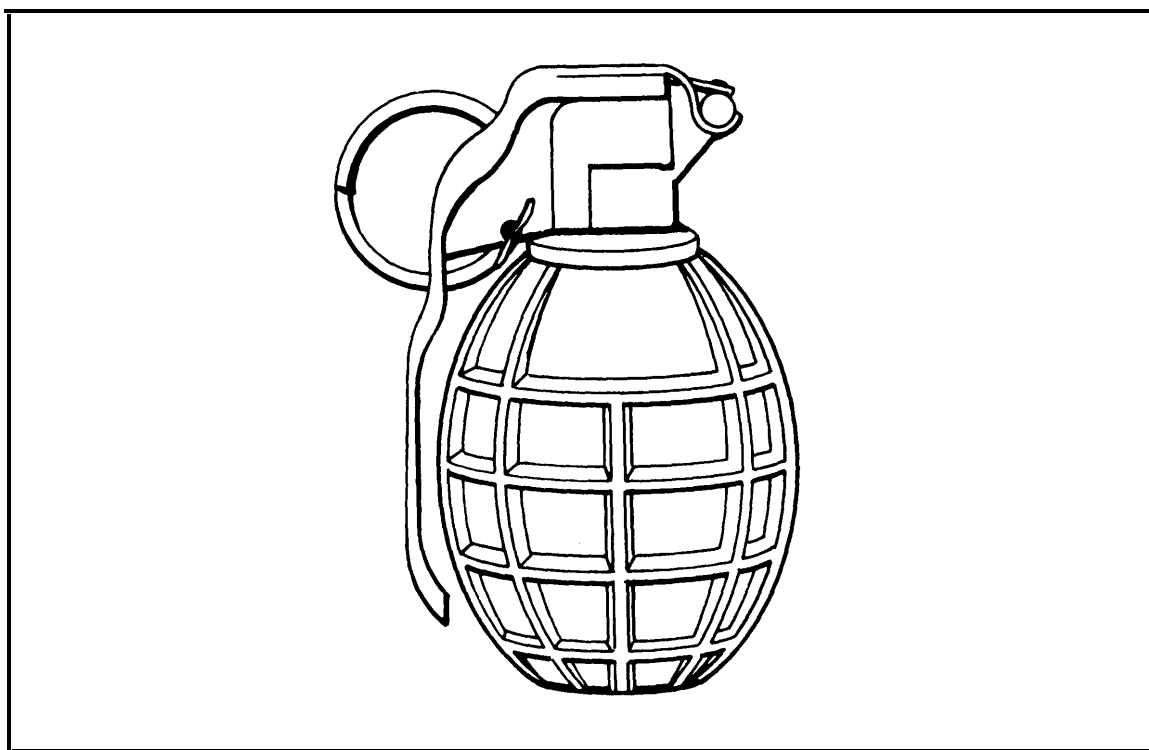

Figure F-24. Type 73.

APPENDIX G

HAND GRENADE QUALIFICATION SCORECARD

This appendix provides a blank copy of a revised addition of DA Form 3517-R. This form is not available through normal supply channels. It may be reproduced locally on 8 1/2 x 11 inch paper.

## HAND GRENADE QUALIFICATION SCORECARD

For use of this term, see FM 23-30, the proponent agency is TRADOC

**NOTE:** In Addition to the Requirements on this Scorecard, the Soldier Must Throw Two Live Fragmentation Grenades to Qualify.

A. DATE LIVE GRENADES WERE THROWN		B. INITIALS		
C. NAME ( <i>Last, First, Middle initial</i> )		D. DATE		
E. GRADE	F. SSAN	G. UNIT		
H. STATION	I. TYPE TARGET	J. GO	K. NO-GO	L. SCORER INITIALS
1	Engage Enemy from Fighting Positions at 35 Meters (25 Meters - Females)			
2	Engage Bunker			
3	Engage 82-MM Mortar Position at 20 Meters			
4	Engage Enemy Behind Cover at 20 Meters			
5	Engage Trench at 25 Meters			
6	Engage Wheeled Vehicle at 25 Meters			
7	Identify Hand Grenades			

### M. QUALIFICATION STANDARD

PASSED 7	EXPERT	CHECK
PASSED 6	FIRST CLASS	
PASSED 5	SECOND CLASS	
PASSED 4 OR LESS	UNQUALIFIED	

N. SIGNATURE OF SCORER/OIC

STATION 1 Engage Enemy From Fighting Position at a Range of 35 Meters (25 Meters for Females) (Standing)			STATION 6. Engage Vehicle at 25 Meters (Kneeling)		
PERFORMANCE MEASURES	GO	NO-GO	PERFORMANCE MEASURES	GO	NO-GO
A. Detonated at Least One Grenade Within 5 Meters of the Center of Target			A. Detonated Within 1 Meter of Vehicle or Within 5 Meters of Dismounting Troops.		
B. Kept Exposure Time Under 3 Seconds.			B. Kept Exposure Time Under 3 Seconds.		
C. Returned to Covered Position After Each Throw.			C. Returned to Covered Position After Each Throw.		
D. Used Proper Grip			D. Used Proper Grip.		
E. Used Proper Throwing Techniques.			E. Used Proper Throwing Techniques.		
F. Completed Performance Measures 1A Through 1E Within 15 Seconds.			F. Completed Performance Measures 6A Through 6E Within 15 Seconds.		
STATION 2. Engage Bunker			STATION 7. Identify Hand Grenades		
A. Approached from Blind Side.			A. Selected Fragmentation Grenade to Engage Enemy Soldiers.		
B. Checked for Bunker Opening			B. Identified M8 Grenade as "White Smoke" or HC Smoke.		
C. Detonated Grenade In Bunker			C. Identified M18 Grenades as "Colored Smoke" or "Purple (Etc.) Smoke". (If Specific Color is Stated, it Must be the Same as Color on the Training Aid Grenade Used.)		
D. Relied Away from Bunker.					
E. Used Proper Grip.					
F. Completed Performance Measures 2A Through 2E Within 15 Seconds.			D. Identified M25A2 Grenade as CS or Riot Control.		
STATION 3. Engage 82-MM Mortar Position at 20 Meters (Kneeling)			E. Identified M14 Grenades as Incendiary.		
A. Detonated at Least One Grenade Inside Mortar Position.			<p><b>NOTE: FOR PERFORMANCE MEASURES 7A THROUGH 7E. IF EXAMINEE CANNOT CORRECTLY STATE NAME OF GRENADE, BUT CAN CORRECTLY IDENTIFY ITS USE, THEN THE EXAMINEE WILL BE SCORED A "GO".</b></p> <p><b>NOTE: EACH PERFORMANCE MEASURE AT EACH SECTION WILL BE GRADED ON A PASS/FAIL STANDARD. A SOLDIER MUST PASS ALL OF THESE STANDARDS TO RECEIVE A "GO" ON THAT STATION.</b></p>		
B. Kept Exposure Time Under 3 Seconds.					
C. Returned to Covered Position After Each Throw.					
D. Used Proper Grip.					
E. Used Proper Throwing Techniques.					
F. Completed Performance Measures 3A Through 3E Within 15 Seconds.					
STATION 4. Engage Enemy Behind Cover at 20 Meters (Alternate Prone)					
A. Detonated at Least One Grenade Within 5 Meters of the Center of Target					
B. Kept Exposure Time Under 3 Seconds.					
C. Returned to Covered Position After Each Throw.					
D. Used Proper Grip.					
E. Used Proper Throwing Techniques.					
F. Completed Performance Measures 4A Through 4E Within 15 Seconds					
STATION 5. Engage Trench at 25 Meters (Kneeling)					
A. Detonated at Least One Grenade Inside Trench.					
B. Kept Exposure Time Under 3 Seconds.					
C. Returned to Covered Position After Each Throw					
D. Used Proper Grip					
E. Used Proper Throwing Techniques					

## GLOSSARY

## Acronyms and Abbreviations

ammo	ammunition
AR	Army regulation
ARTEP	Army Training and Evaluation Program
ASP	ammunition supply point
CN	tear gas
comp	composition
CS	combat support, tear gas
CSS	combat service support
DA	Department of Army
DM	vomiting gas
EOD	explosive ordnance disposal
FM	field manual, frequency modulated
HC	hydrochloric
HG	hand grenade
HQ	headquarters
LBE	load-bearing equipment
LCE	load-carrying equipment
MBA	main battle area
METL	mission essential task list
METT-T	mission, enemy, terrain, troops, and time available



mm	millimeter
MOPP	mission-oriented protection posture
NATO	North Atlantic Treaty Organization
NCO	noncommissioned officer
NCOIC	noncommissioned officer in charge
NSN	national stock number
OD	olive drab
OIC	officer in charge
PA	public address
RATELO	radiotelephone operator
RDX	cyclonite
SOP	standing operating procedure
STX	situational training exercise
TH	thermate
TM	technical manual
TNT	trinitrotoluene
TRADOC	Training and Doctrine Command
US	United States
WP	white phosphorous

## REFERENCES

## Required Publications

Required publications are sources that users must read in order to understand or to comply with this publication.

Technical Manuals (TM)

9-1330-200-12	Operator's and Organizational Maintenance Manual for Grenades
9-1370-206-10	Operator's Manual: Pyrotechnic Signals

## Related Publications

Related publications are sources of additional information. They are not required in order to understand this publication.

Army Regulation (AR)

385-63	Policies and Procedures for Firing Ammunition for Training, Target Practice, and Combat
--------	---

Field Manuals (FM)

5-25	Explosives and Demolitions
7-8	The Infantry Platoon and Squad (Infantry, Airborne, Air Assault, Ranger)
7-70	Light Infantry (Platoon and Squad)
21-11	First Aid for Soldiers

DA Forms

3517-R	Hand Grenade Qualification Scorecard
--------	--------------------------------------

## INDEX

- ammunition pouch
  - new style, 2-2 (illus)
  - old style, 2-2, 2-3 (illus)
  - precautions, 2-1
- assaults
  - clearing a bunker, 3-6
  - clearing a room, 3-7
  - clearing a trench, 3-5
  - conducting a raid, 3-8
  - reacting to ambush, 3-8
- basic load, 3-2
- carry, 2-1, C-5
- checklist, live range operations, B-1 thru B-7
- components, 1-1
- defense
  - against armored vehicles, 3-10, 3-11 (illus)
  - base cluster, 3-15
  - from fighting position, 3-9 (illus)
- dropped grenades, C-2
- duds, C-2
- employment
  - at night, 3-15
  - defensive, 3-8 thru 3-13
  - offensive, 3-3 thru 3-8
  - rear area operations, 3-14
  - retrograde, 3-13 thru 3-14
  - rules 3-3
  - while in MOPP 4 gear, 3-15
- fragmentation grenade
  - M61, 1-8 (illus)
  - M67, 1-9 (illus)
- fuzes
  - detonating, 1-4
  - functioning, 1-3 (illus)
  - igniting, 1-6

grenades, current US Army  
 fragmentation, M61, 1-8 (illus)  
 fragmentation, M67, 1-9 (illus)  
 incendiary, AN-M14 TH3, 1-16, 1-17 (illus)  
 offensive, MK3A2, 1-17, 1-18 (illus)  
 practice, M69, 1-18, 1-19 (illus)  
 riot control  
 ABC-M7A2 CS, 1-14 (illus)  
 ABC-M7A3 CS, 1-14 (illus)  
 ABC-M25A2, 1-15 (illus)  
 smoke  
 AN-M8 HC, 1-11, 1-12 (illus)  
 M15 WP, 1-10 (illus)  
 M18, 1-12, 1-13 (illus)

grenades, NATO (all illus)  
 Austria, F-19  
 Belgium, F-12  
 Germany, F-9  
 Netherlands, F-1  
 United Kingdom, F-13

grenades, obsolete (all illus)  
 ABC-M7A2, D-6  
 ABC-M25A1/A2, D-8  
 M6 & M6A1, D-7  
 M7 & M7A1, D-5  
 M26 & M26A1, D-4  
 M30, D-1  
 M34, D-9  
 MK1, D-2  
 MK2, D-3

grip, 2-3, C-4

illumination kits, 5-7, 5-8 (illus), 5-9 (illus)

incendiary grenade  
 AN-M14 TH3, 1-16, 1-17 (illus)

offensive grenade  
 MK 3A2, 1-17, 1-18 (illus)  
 special usage, 3-14

practice grenade  
 M69, 1-18, 1-19 (illus)  
 special usage, 3-14

- procedures
  - carrying, 2-1
  - gripping, 2-3, 2-4 (illus)
  - throwing, 2-5 thru 2-9 (illus)
- pyrotechnics
  - ground smoke signals, 5-1, 5-2 (illus)
  - hand-held signals, 5-1, 5-2 thru 5-5
- range
  - dimensions, E-1
  - layout, E-1
  - observation pits, E-2
  - operations checklist, B-1 thru B-7
  - safety, App C
  - throwing pits, E-2
- safety
  - dropped grenades, C-2
  - duds, C-2
  - from helicopters, C-4
  - general, C-1
  - grip, C-4
  - while airborne, C-5
- safety clip
  - insertion, 1-1, 1-2 (illus)
  - obsolete, D-10 (illus)
- scorecard
  - instructions, 4-7 thru 4-10 (illus)
  - reproducible form, G-1
- simulators, 5-6 (illus), 5-7 (illus)
- smoke parachutes, 5-4, 5-5
- star clusters, 5-3, 5-4
- star parachutes, 5-4
- surface trip flares, 5-5 (illus)
- Threat grenades (all illus)
  - F-1, A-3
  - RGD-1, A-7
  - RGD-2, A-8
  - RGD-5, A-5
  - RGN, A-1
  - RGO, A-2
  - RKG-3M, A-4
  - RG42, A-6

throw, 2-6

training

- collective tasks, 4-17, 4-19 (illus)
- courses, 4-1
- objectives, 4-1
- scorecard, 4-9 (illus), 4-10 (illus)

training courses

- ammunition, 4-16
- confidence, 4-11, 4-12 (illus)
- distance and accuracy, 4-2, 4-3 (illus)
- facility, 4-15
- live pit, 4-4, 4-5, 4-6 (illus)
- practice pit, 4-4
- qualification, 4-7, 4-8, 4-11 (illus)
- ranges, 4-16, 4-17
- safety personnel, 4-14
- target, 4-17

**FM 23-30**  
**27 DECEMBER 1988**

By Order of the Secretary of the Army:

**CARL E. VUONO**  
*General, United States Army*  
*Chief of Staff*

Official:

**WILLIAM J. MEEHAN II**  
*Brigadier General, United States Army*  
*The Adjutant General*

**DISTRIBUTION:**

*Active Army, USAR, and ARNG:* To be distributed in accordance with DA Form 12-11E, Requirements for Grenades and Pyrotechnic Signals (Qty rqr block no. 196).