

No. 1917

DESCRIPTION AND RULES FOR THE
MANAGEMENT OF THE
UNITED STATES RIFLE

CALIBER .30, MODEL OF 1917

OCTOBER 8, 1917

REVISED JANUARY 16, 1918



WASHINGTON
GOVERNMENT PRINTING OFFICE
1918

WAR DEPARTMENT,
OFFICE OF THE CHIEF OF ORDNANCE,
Washington, January 16, 1918.

This manual is published for the information and government of the Regular Army,
National Guard, and National Army of the United States.

By order of the Secretary of War:

C. B. WHEELER,
*Brig. Gen., Ordnance, N. A.,
Acting Chief of Ordnance.*

(3)

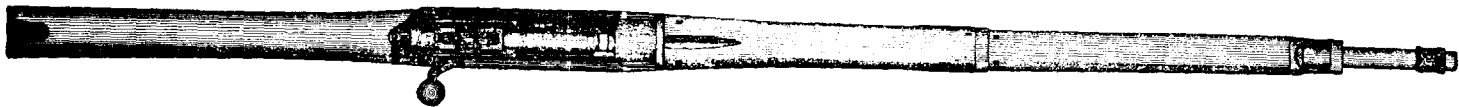

FIG. 1

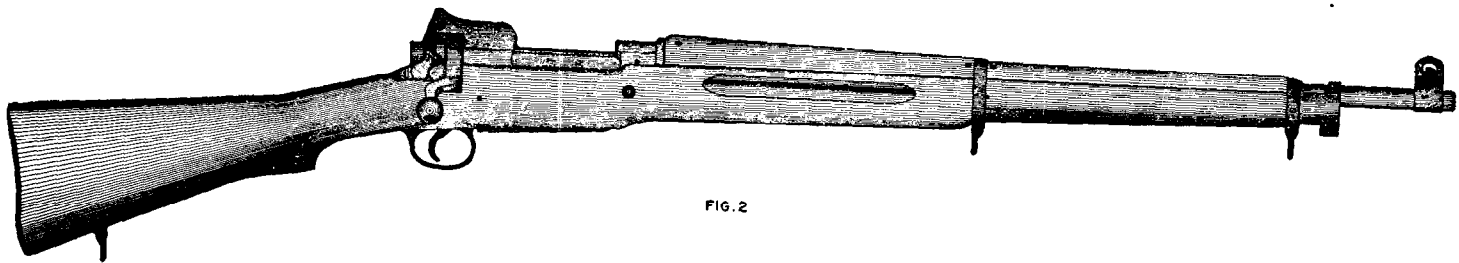

FIG. 2

UNITED STATES RIFLE, CALIBER .30, MODEL OF 1917.

COMPONENT PARTS OF RIFLE.

(Eighty-six in number of which seventy-seven are not duplicates.)

Barrel:	Guard.
Barrel.	Guard screw bushing, front.
Spline.	Guard screw bushing, rear.
Bolt:	Guard screw, front.
Bolt.	Guard screw, rear.
Extractor collar.	Hand guard:
Bolt stop:	Hand guard, front.
Bolt stop.	Hand guard, rear.
Bolt stop screw.	Hand guard liner, front.
Bolt stop spring.	Hand guard liner, middle.
Bolt stop spring rest.	Hand guard liner, rear.
Butt plate:	Hand guard rivets, (6).
Butt plate.	Hand guard ring.
Butt plate cap.	Lower band.
Butt plate pin.	Lower band screw.
Butt plate screw, large.	Lower band pin.
Butt plate screw, small.	Lower band swivel.
Butt plate spring.	Magazine.
Butt plate spring screw.	Magazine spring.
Butt swivel:	Main spring.
Butt swivel.	Rear sight:
Butt swivel screw.	Base spring.
Butt swivel plate.	Base spring screw
Butt swivel plate screws (2).	Joint bolt.
Ejector.	Joint bolt nut.
Extractor.	Leaf.
Firing pin:	Slide.
Striker.	Slide catch.
Cocking piece.	Slide catch spring.
Floor plate.	Slide catch pin.
Floor plate catch.	Slide stop screw.
Floor plate pin.	Receiver.
Floor plate spring.	Safety lock:
Follower.	Safety lock.
Front sight:	Safety lock holder.
Front sight.	Safety lock holder screw.
Front sight carrier.	Safety lock plunger.
Front sight carrier pin.	Safety lock spring.

Sear.	Stock bolt.
Sear pin.	Stock bolt nut.
Sear spring.	Stock pin.
Sleeve.	Trigger.
Stacking swivel.	Trigger pin.
Stacking swivel screw.	Upper band.
Stock.	Upper band screw.

APPENDAGES.

Oiler and thong case:	Thong:
{ Thong case body.	Thong brush.
{ Thong case partition.	Thong cord.
{ Oiler collar.	Thong tip.
{ Oiler cap.	Thong weight.
{ Oil dropper.	
{ Oiler cap washer.	
{ Thong case cap.	
{ Thong case pad.	

ACCESSORIES.

Cleaning rod, barrack; model of 1916:	Cleaning rod, model of 1916—Con.
Collar.	Sleeve.
Knob.	Second section.
Rod.	Third section.
Sleeve.	Cleaning rod case.
Cleaning rod, model of 1916:	Follower depressor.
Brush section.	Screw-driver:
Handle section.	Screw-driver blade, large.
Knob.	Screw-driver blade, small.
Collar.	Screw-driver pin.
	Screw-driver rivet.

COMPONENT PARTS OF BAYONET, MODEL OF 1917.

(Ten in number.)

Bayonet blade.	Bayonet grip, right.
Bayonet catch.	Bayonet grip, left.
Bayonet catch spring.	Bayonet screws (2).
Bayonet catch thumbpiece.	Bayonet screw nuts (2).

GENERAL DESCRIPTION.

The rifle has a breech mechanism of the bolt type, the bolt being locked by a turning movement, which causes lugs on the bolt to engage in recesses just in rear of the chamber. There is a camming action of the locking lugs to seat cartridges firmly, which continues throughout the locking action. To preclude the possibility of the bolt's unlocking under powder pressure, a safety stud is mounted on the sear and rises, as the trigger is pulled, to lock the bolt against turning. This serves also to preclude pulling of the trigger unless the bolt is fully locked.

The magazine is directly beneath the bolt and is loaded from the top from a clip of five cartridges while the bolt is retracted. It contains a spring-actuated follower, above which the cartridges arrange themselves in laterally staggered relation.

This follower feeds the top cartridge up into the path of the bolt when the latter is retracted, a ramp serving to guide the nose of the bullet upward and into the chamber as the cartridge is forced forward on the succeeding forward movement of the bolt.

The extractor is of the hook type, swiveled on the bolt, and engages the groove of the cartridge as this moves upward from the magazine. Primary extraction is provided by an extracting cam, operated by the turning of the bolt in unlocking, and serving to start the bolt to the rear after it is unlocked.

The ejector is of the spring-actuated type and operates through a slot in one of the locking lugs at the limit of rearward movement of the bolt. The ejector spring is integral with the ejector.

The firing pin has no cocking knob and can not be cocked except by actuation of the bolt. It is half cocked by the unlocking movement of the bolt, a cam and half-cock notch being provided on the rear end of the bolt to engage a lug on the cocking piece and perform this function. The sear notch of the cocking piece engages the sear nose in the closing movement of the bolt, so that the piece is cocked by the act of closing the bolt. The locking of the bolt moves the half-cocking cam out of the path of the lug on the cocking piece. This arrangement precludes the closing of the bolt upon a cartridge with the point of the striker protruding through the end of the bolt.

There is no magazine cut-off. The follower rises and locks the bolt open when the magazine is empty, and to prevent this, so that the rifle may be used as a single loader or in simulated fire drill, an accessory, called the follower depressor, is provided.

The safety lock consists of an eccentric detent which engages a notch in the cocking-piece lug and lifts the sear notch off the sear nose, and a sliding plunger, which simultaneously enters a hole in the bolt handle and locks the bolt closed. These parts are operated

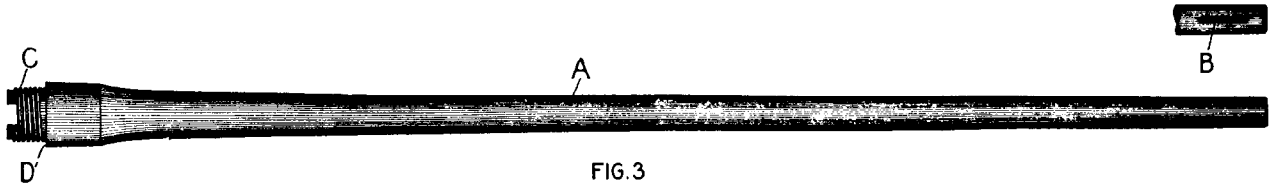

FIG. 3

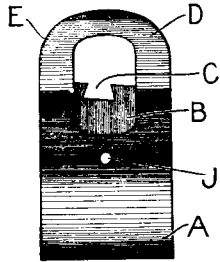

FIG. 4

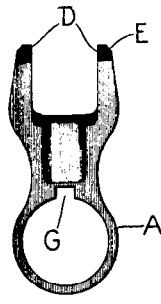

FIG. 5

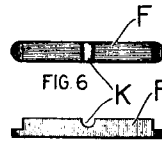

FIG. 6

FIG. 7



FIG. 8

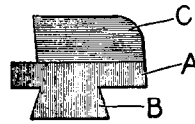

FIG. 9

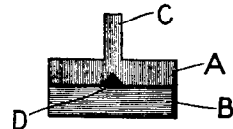

FIG. 10

by a thumb piece, mounted at the right, just in rear of the bolt handle, in position for convenient actuation by the right thumb.

The bolt stop engages one of the locking lugs. It is spring held, and may be retracted to permit withdrawal of the bolt at the rear. The firing pin and sleeve can be removed from the bolt and completely dismantled without the use of tools.

The front sight is protected by lateral wing guards, and may be adjusted laterally during assembly. Height adjustment is secured by the interchange of sights of different heights.

The rear sight is protected by lateral wing guards. The battle sight is of the peep type and, being formed at the lower end of the leaf, rises to position as the leaf is laid. The leaf carries a peep sight, on a slide which moves vertically, and hence makes no correction for drift. There is no windage adjustment.

The sling, stacking swivel, and accessories are of familiar types and need no preliminary description.

The ammunition is the U. S. Caliber .30 Rifle Cartridge, Model of 1906, five cartridges in a clip. These are the same cartridge and clip as are used in the U. S. Rifle, Caliber .30, Model of 1903.

DESCRIPTION AND NOMENCLATURE OF RIFLE PARTS.

The rifle is shown in plan in Fig. 1 and in elevation in Fig. 2.

The BARREL A, with the *spline seat* B, is shown in Fig. 3. It is 26.05 inches in length, and the rifling consists of 5 grooves approximately 0.005 inch deep. The lands and grooves are of equal width. The twist is left-hand and uniform, 1 turn in 10 inches.

The muzzle is rounded to protect the rifling. The *tenon* C at the rear is square-threaded for the purpose of securing the receiver to the barrel. A *shoulder* D is provided to form a seating for the receiver.

The FRONT SIGHT CARRIER is shown in side elevation in Fig. 4, and front elevation in Fig. 5. It is mounted near the front end of the barrel. It includes in one piece, a *collar* A, a *fixed base* B provided with a transverse dovetailed *way* C, to receive the sight blade hereafter described, and two *sight guards* DD which project upward above the front sight and protect the same from injury. The upper portions of the guards DD of the front sight carrier are knurled or serrated, as shown at E, to prevent any reflection of light from this surface, such as would interfere with aiming.

The front sight carrier is held in position by means of the SPLINE F, illustrated in detail in Figs. 6 and 7, which are top and side views. This spline is seated and fits closely in the spline seat in the top of the barrel (see B, Fig. 3), and is thus held against movement in any direction. It fits in a *keyway* G in the collar A of the front sight carrier and is locked to said carrier by the FRONT SIGHT CARRIER PIN H (see Fig. 8), which passes through a *transverse hole* J in the front sight carrier and engages a *notch* K in the top of the spline F.

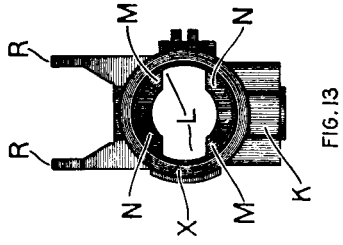
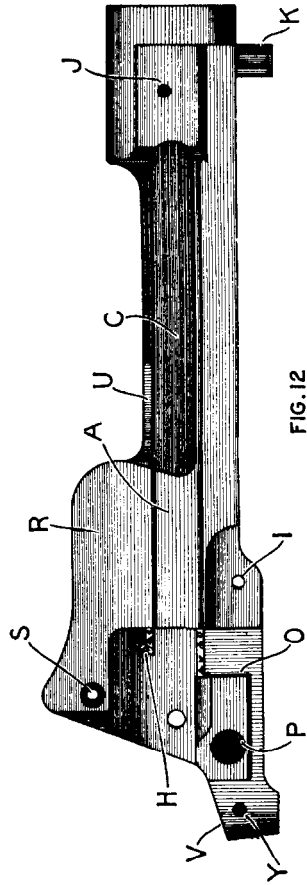
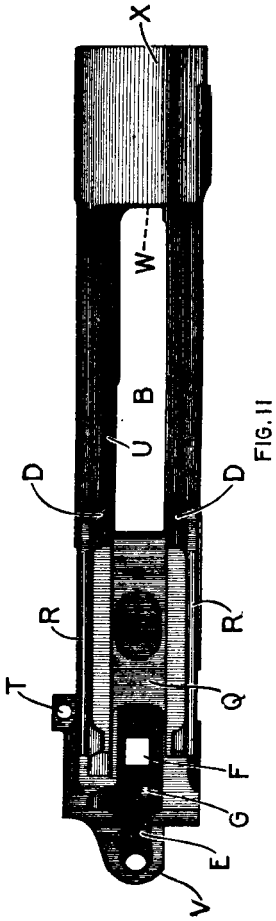

The removal of the front sight carrier should not be attempted, except at armories properly equipped for this work.

The FRONT SIGHT is shown in side elevation in Fig. 9 and front elevation in Fig. 10. It has a *base A*; *base lug B*; *blade C*, and *lock seat D*. The lug B fits closely in the transverse dovetailed way of the sight carrier and is locked, after adjustment, by upsetting part of the metal of the base into lock seat D with a punch. Vertical adjustment is secured by substitution of different front sights. Eleven sizes are used, varying by 0.015 inch increments between 0.985 inch and 1.135 inch, the lowest size being marked $-.015$, the next 0, the next $.015$, the next $.03$, and so on to $.135$.

At the top of the barrel and at the rear of the front sight carrier is stamped a letter which indicates the place of manufacture, the Ordnance escutcheon, and numerals indicating the month and year of manufacture.

The RECEIVER is shown in Figs. 11, 12, and 13, which are, respectively, a top view, a right side view, and a front end view. The receiver is made in one piece and comprises the following elements: The *well A*, through which the bolt slides; the *magazine opening B*; the *channel C*, for the top locking lug of the bolt; the *clip slots D*, which retain a clip in position during the loading operation; the *cocking piece groove E*, in which the lug of the cocking piece is guided; the *sear nose slot F*, through which the sear nose works; the *safety lock slot G*; the *extracting cam H*; the *sear pin hole I*; the *gas-escape hole J*; the *recoil lug K*, in which is the hole for the front guard screw; the *recesses LL*, for the bolt-locking lugs; the *locking cams MM*; the *locking shoulders NN*, which are slightly inclined so as to exert a powerful closing action on the bolt when loading; the *safety shoulder O*, which engages the bolt handle in the closed position; the *safety-lock bearing P*; the *rear sight base Q*, provided with the *rear sight guards RR*; *rear sight joint holes S*; *bolt stop screw hole T*; *thumb recess U* to give clearance for the thumb when forcing cartridges from a clip into the magazine; *rear tang V*, which has a hole to receive the rear-guard screw; *cartridge ramp W*; *threaded hood X*; and *safety-lock holder screw hole Y*. There are also two slots, not visible in the cuts. The first, known as the *bolt-stop opening*, is through the left side of the well A, and receives the bolt stop and ejector. The second, known as the *safety-stud slot*, is in the bottom of the well A and allows the safety stud on the sear to interlock with the bolt. It can be seen in Fig. 146. As shown, the receiver is open at the top to permit the insertion of cartridges and at the right to permit ejection.

The threaded hood X is screwed on to the end of the barrel, and firmly breeched against the shoulder formed on the barrel (see D, Fig. 3). The removal of receivers from barrels should be attempted only in armories equipped with proper appliances for this work.

On the upper surface of the receiver, at the front end, is stamped "U. S.," "Model of 1917," together with the name of the maker and the serial number of the rifle.

The BOLT is shown in Figs. 14, 15, and 16, which are, respectively, plan, rear, and front elevations. It comprises the following elements: The *handle* A; the *locking lugs* BB, which sustain the shock of discharge, the upper lug being slotted to allow the passage of the point of the ejector; a *safety lug* C, formed as a part of the handle, and capable of sustaining the recoil of the bolt upon failure of the locking lugs; the *extractor collar groove* D; *extracting cam* E; *safety lock plunger recess* F; *firing-pin hole* G; *half-cocking cam* H, which half cocks the piece by the unlocking (turning) movement of the bolt; the *half-cock notch* I; the *extractor-tongue groove* J; *gas-escape holes* KK, also shown in Fig. 147; *rim* M; *clearance* N, which permits the safety stud on the sear to rise as the sear nose is depressed by the cocking piece, during the opening movement of the bolt; and *interlock slot* O which is so placed as to receive the safety stud on the sear only when the bolt is fully locked.

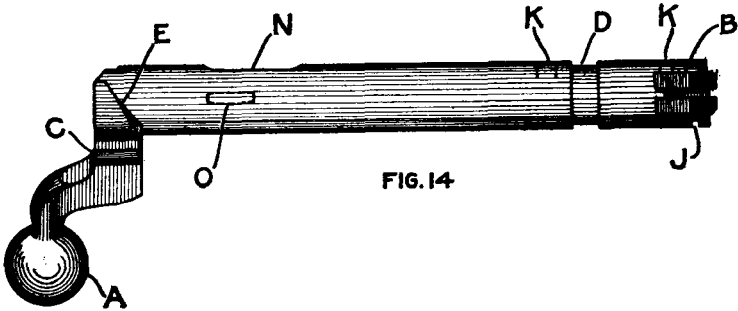

FIG. 14

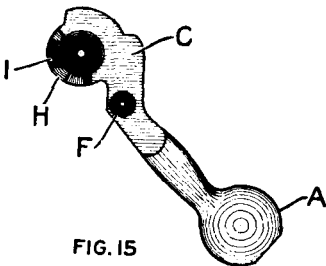

FIG. 15

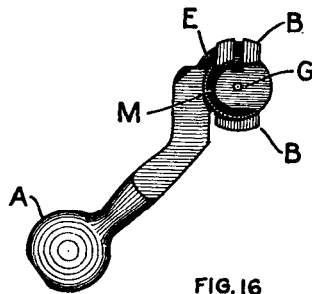

FIG. 16

The SLEEVE is shown in Figs. 17, 18, and 19, which are respectively rear end elevation, right side elevation and bottom view. It comprises the *barrel A*, threaded for the purpose of securing the sleeve to the bolt; a central guide or *way B*, through which the striker works, formed with flat sides to engage flats on the striker and prevent turning thereof; the *counter bore C*, at the rear, in which the cocking piece works; the *cocking piece slot D*, to receive and guide the lug on the cocking piece, and the *sight clearance E*, which receives the battle sight, should the leaf accidentally be struck back.

The bolt is bored out from the rear to receive the striker, and is internally threaded at the rear end of the bore to receive the sleeve. The sleeve is screwed into the rear end of the bolt, and serves to guide the striker and cocking piece, which are assembled to form the firing pin. The sleeve also receives the thrust of the main spring which surrounds the striker between a collar thereon and the sleeve. The sleeve partakes of all the longitudinal movements of the bolt, but swivels in the bolt on its threaded connection when the bolt is turned to lock and unlock it.

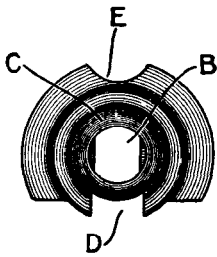

FIG. 17

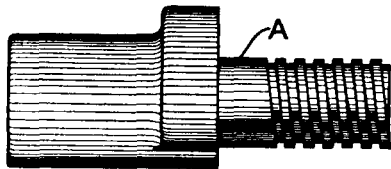

FIG. 18

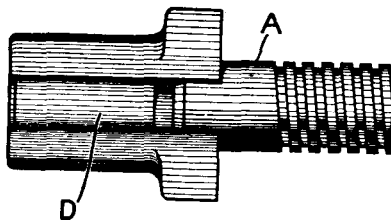

FIG. 19

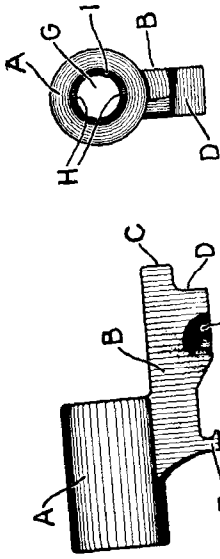

FIG. 21

FIG. 20

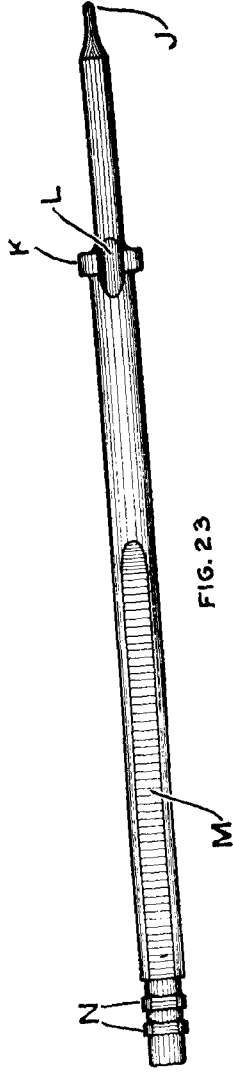

FIG. 23

FIG. 22

FIG. 25



FIG. 24



The **FIRING PIN** consists of a cocking piece and striker. The **COCKING PIECE** is shown in Figs. 20 and 21, which are respectively right side and front end elevations. It is made in one piece and comprises a *barrel A*; a *lug B*; *cocking cam C*; *sear notch D*; *safety lock notch E*; and *dismounting hook F*. The cocking piece has a *longitudinal hole G* provided with *lugs H*, which engage or release lugs on the striker by a quarter-turn movement of the cocking piece on the striker. A *shoulder I* facilitates the positioning of the striker in the cocking piece, preparatory to locking the two together. The **STRIKER** is shown in Figs. 22, 23, and 24, which are respectively rear end, side, and front end views. It comprises a *point J*; *collar K*; *gas vents L*; *flats M*; and *locking lugs N*. The rear end of the striker will enter the hole G in the cocking piece until the end lug N strikes shoulder I. The two may then be locked together by a quarter-turn movement, and will be retained in locked position by the sleeve, since the sleeve engages both the flats on the striker and the lug on the cocking piece.

The **MAIN SPRING** is shown in Fig. 25. It surrounds the striker between the sleeve and collar K on the striker. It may be sufficiently compressed to allow the sleeve to free the cocking piece, so that this can be turned and released from the striker.

The **EXTRACTOR** is shown in Figs. 26, 27, and 28, which are respectively inside, edge, and front end views. It comprises the *hook A*, by which the cartridge case is extracted from the chamber; the



FIG. 26

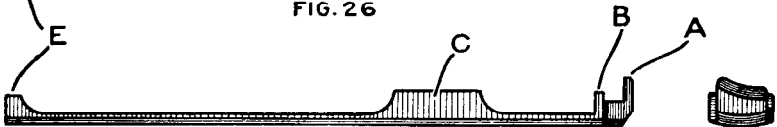

FIG. 27

FIG. 28

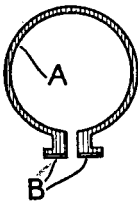

FIG. 29



FIG. 30

tongue B, which rides in its groove in the front end of the bolt; the *lug C*, which has an undercut slot to receive the ears on the extractor collar; the *gas escape hole D*, and the *back rest E*.

The EXTRACTOR COLLAR is shown in Figs. 29 and 30, which are respectively end and side views. It comprises the *collar A*, and *ears BB*. It is sprung into the groove on the bolt, and should not be removed except at properly equipped armories.

The extractor may be readily mounted on, and dismantled from, the ears on the collar, when these are turned to align with the gas-escape holes on the bolt. (See K, Fig. 14.) The extractor tongue groove on the bolt does not extend clear around the bolt, and is absent in this position, so that the extractor may be drawn forward to release its undercut lug from the ears on the collar.

The BOLT STOP is shown in Figs. 31, 32, 33, 34, and 35, which are, respectively, right side, plan, front end, left side, and rear end views. The stop comprises the *stop lug A*, which projects into the well of the receiver, and arrests the slotted lug on the bolt at the limit of the rearward movement of the bolt; *ejector slot B*; *spring seat C*; *thumb piece D*; *pivot lugs E* and *bolt stop screw hole F*. The EJECTOR (Fig. 36), comprising the *point G*, *spring H* and *pivot hole I*, is mounted in the ejector slot B, the ejector and bolt stop being held by the BOLT STOP SCREW (Fig. 37) which serves as a pivot for both, and is screwed into the bolt stop screw hole in the receiver. (See T, Fig. 11.) The BOLT STOP SPRING shown in side view in Fig. 38 and in plan in Fig. 39 has a bifurcated *lug L* which enters into positive engagement with the bolt stop in the *spring seat C* thereof. The opposite, or *free end M* bears in the *spring seat N* of the BOLT STOP SPRING REST shown in Figs. 40 and 41. The *stud O* of this spring rest is seated in a hole in the side of the receiver.

The bolt stop, ejector and spring thus form a single assembled unit, the point G of the ejector being in advance of the stop lug A and being protruded laterally by its own spring H, which bears at its end on the bolt stop spring. When the bolt is fully drawn back, with the locking lug against the bolt stop, the point G, extending through the slot in the locking lug of the bolt, projects beyond the front end of the bolt to perform its ejecting function.

To release the bolt, so that it may be drawn out to the rear through the well, the thumb piece D is pulled to the left, retracting the lug A. Since the lug A bridges the ejector slot B, it engages and retracts the ejector at the time of its own retraction.

The SAFETY LOCK is shown in left-side view in Fig. 42 and in rear view in Fig. 43. It includes the following elements: *Thumb piece A*; *journals B*; *locking cam C*, and *plunger actuating cam D*. The safety lock is swiveled in a bearing formed in the receiver (see P, Fig. 12), and the cam C works through a slot in the lug slot of the receiver (see

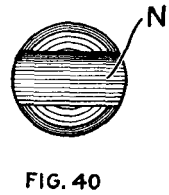
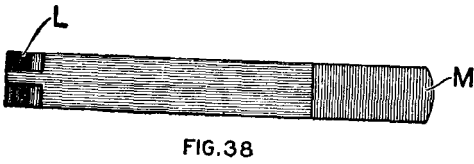
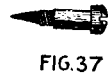
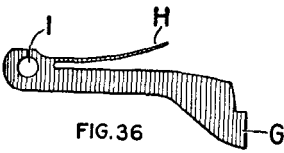
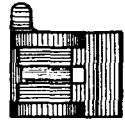
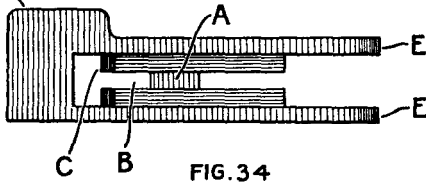
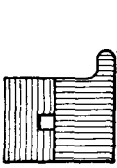
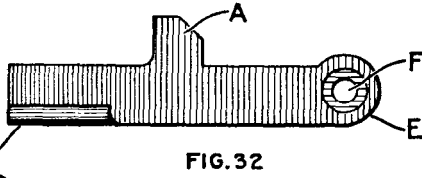
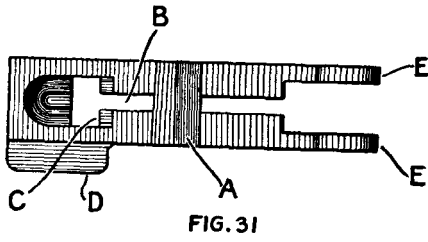

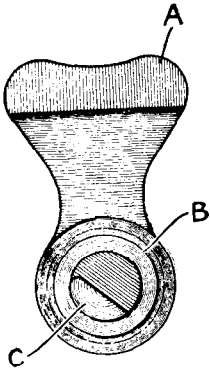

FIG. 42

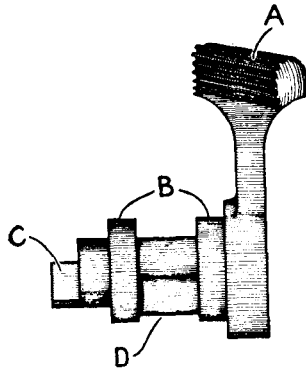

FIG. 43



FIG. 44

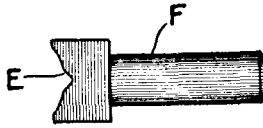

FIG. 45



FIG. 46

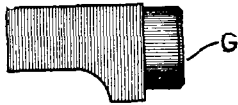

FIG. 47



FIG. 49



FIG. 48

G, Fig. 11), to engage the safety-lock notch in the cocking-piece lug (see E, Fig. 20), retract the cocking piece sufficiently to lift the sear notch off the sear nose, and hold it, so that the piece can not be discharged. The retraction of the cocking piece frees the sear nose, so that it will certainly return to normal or raised position, after any manipulation of the trigger while the safety lock is set "safe."

The cam D of the safety lock actuates the SAFETY-LOCK PLUNGER shown in rear view in Fig. 44 and side elevation in Fig. 45. This slides in a guide formed in the receiver and includes a *detent head E* and a *plunger F*. The SAFETY-LOCK SPRING, Fig. 46, surrounds the plunger F and urges the detent head E against the plunger actuating cam D. The cam D thus actuates the plunger F, and together with the detent head E, serves as an impositive latch or detent for the safety lock. The "safe" position of the thumb piece A is to the rear, in which position cam C performs its locking function, and plunger F is protruded into a hole in the bolt handle, to lock the bolt closed (see F, Fig. 15). The "ready" position is forward, the cam C being thus lowered to clear the cocking-piece lug, and the plunger F being retracted by the safety-lock spring.

The safety lock should never be moved to "ready" with the finger on the trigger. The thumb piece should never be left in a vertical position, as this does not render the rifle safe, and may cause injury to the safety lock if the trigger is pulled.

The SAFETY-LOCK HOLDER is shown in plan in Fig. 47, and right-side elevation in Fig. 48. This has a *plug G*, which enters a hole in the receiver at the rear of and at right angles to the bearing for journals B B. The safety-lock holder is held in place by the SAFETY-LOCK HOLDER SCREW, Fig. 49. After removing the receiver and barrel from the stock, the safety lock may be dismantled. The safety-lock holder is removed, and the thumb piece of the safety lock is turned to a vertical downward position. This frees the safety lock from retention by the detent head E. The safety lock is then withdrawn and the plunger and spring removed.

The GUARD is shown in Figs. 50 and 51, which are, respectively, a plan and elevation. It comprises in one piece the following parts: the *bow A*; *front tang B*; *rear tang C*; *floor-plate catch-pin hole D*; *front guard-screw hole E*; *rear guard-screw hole F*; *trigger slot G*; *floor-plate-lug slot H*; *catch-spring seat I*; *floor-plate catch slot K*; *lightening cut L*; and *floor-plate opening M*.

The MAGAZINE is shown in Figs. 52 and 53, which are, respectively, a plan and side elevation. It is shown as constructed of two *side plates A*, a *front end plate B*, and *rear end plate C* riveted together. This construction was used by all manufacturers in early models, but the later practice by some is to connect these parts by spot welding. The end plates B and C have *top lugs D*, which enter the magazine opening of the receiver, and the side plates have *extensions E*, which enter the floor-plate opening of the guard (see M of Fig. 50)

The magazine is clamped between the receiver and guard when assembled, and is held in alinement by the lugs and extensions above mentioned.

The GUARD SCREWS, front and rear, are shown in Figs. 54 and 55, respectively. They connect the front tang of the guard to the recoil lug of the receiver, and the rear tang of the guard to the rear tang of the receiver. GUARD-SCREW BUSHINGS, front and rear, are shown in Figs. 56 and 57, respectively, and serve as distance pieces between the guard and the receiver.

The FLOOR PLATE is shown in Figs. 58 and 59, which are, respectively, a plan and longitudinal section. The floor plate includes the *tenon A*, which fits into a groove at the front end of the magazine-opening in the guard, and with the assistance of the floor-plate catch, retains the floor plate securely in its place in the bottom of the magazine; the *lug B*, which is slotted to receive the floor-plate catch, and has a *tenon C* at its front end, which engages the guard; the *cavity D*, through which the catch may be released by pressing it with the nose of a bullet; the *magazine-spring recess E*; the *magazine-spring seat F*, and the *magazine-spring stop G*.

The FLOOR-PLATE CATCH, Figs. 60 and 61, hinges on the FLOOR-PLATE PIN, Fig. 62, and is held by the FLOOR-PLATE SPRING, Fig. 63. This pin is mounted in a hole formed for it in the guard (see *D*, Fig. 51), and the nose of the catch enters the slot in the floor-plate lug (see *B*, Fig. 58), so that the floor plate is held forward, with its tenons in engagement with the guard.

The MAGAZINE SPRING is shown in perspective in Fig. 64. The spring is of *W*, or zigzag shape, with small loops at the bends. One end is narrowed to fit undercuts in the follower, and the other and wider end fits undercuts in the spring seat of the floor plate.

The FOLLOWER is shown in plan in Fig. 65 and in side elevation in Fig. 66. It has the *rib A*, which serves to locate the cartridges in the magazine and guides the last cartridge into the chamber; the *front stop B* and the *rear stop C*, for the magazine spring; and the *lugs D*, in which are *undercuts* to receive the magazine spring.

The SEAR is shown in Figs. 67, 68, and 69, which are, respectively, plan, right side, and front end elevations. The sear comprises the *sear nose A*, *sear-pin hole B*, *trigger slot C*, *trigger-pin hole D*, and *safety stud E*, which enters into interlocking relation with the bolt to ensure locking of the bolt at the moment of firing. One manufacturer forges the safety stud integrally with the sear. Others form it separately and rivet it in place.

The SEAR SPRING is shown in Fig. 70. It surrounds the safety stud *E* of the sear, and bears at its upper end in a countersink drilled around the safety stud hole in the receiver.

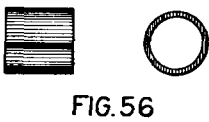
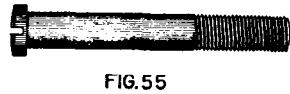
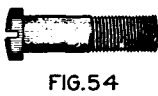
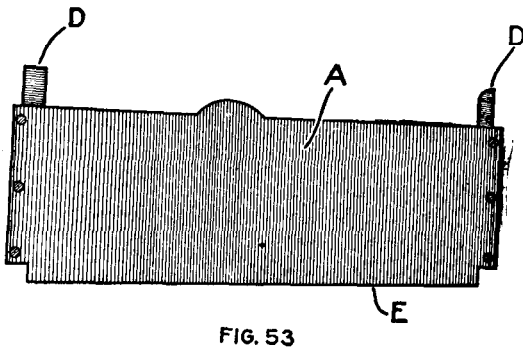
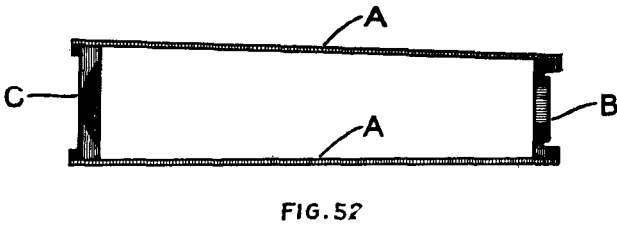
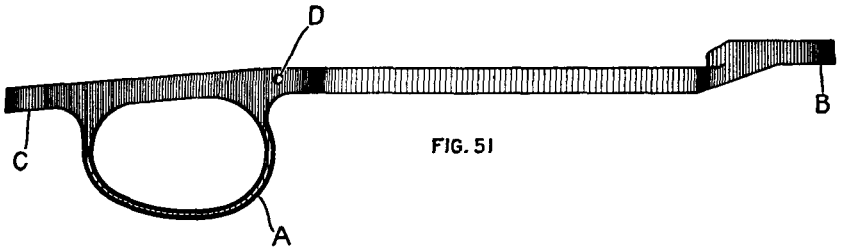
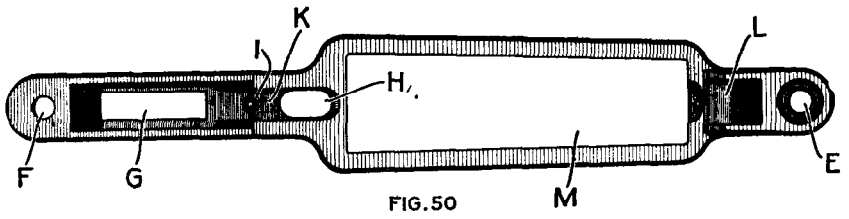

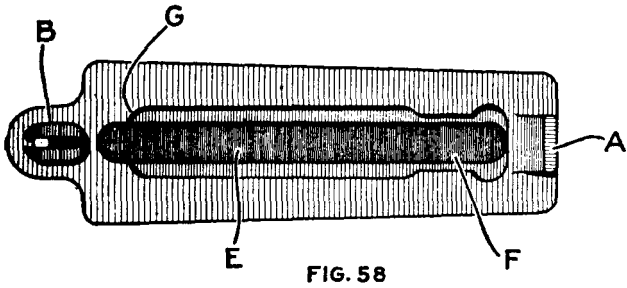

FIG. 58

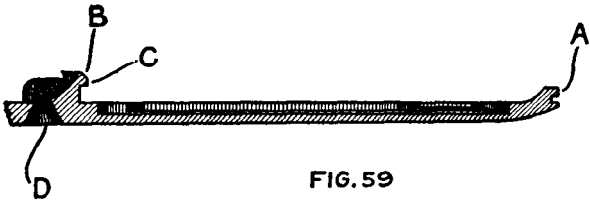

FIG. 59



FIG. 60



FIG. 62

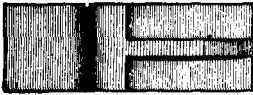

FIG. 61



FIG. 63

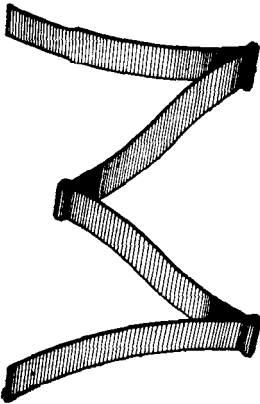

FIG. 64

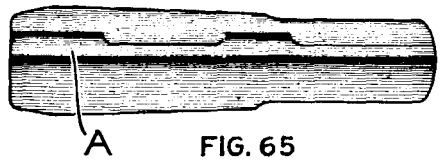

FIG. 65

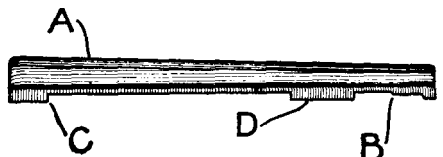

FIG. 66

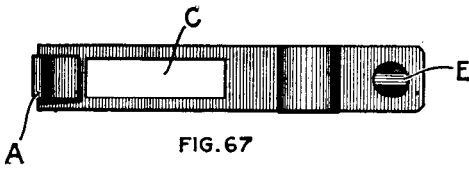

FIG. 67

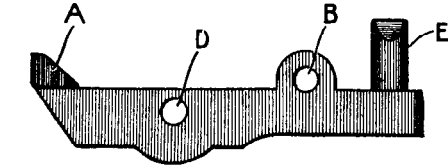

FIG. 68



FIG. 69



FIG. 70



FIG. 71

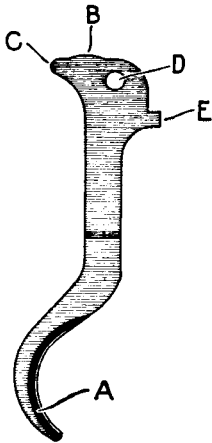

FIG. 72

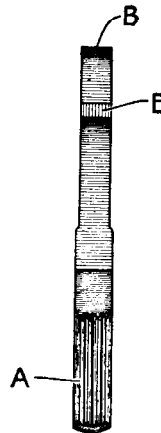

FIG. 73



FIG. 74.

The SEAR PIN is shown in Fig. 71, and hinges the sear to the receiver. The sear pin should not be needlessly removed, as it is difficult to replace.

The TRIGGER, shown in right side view in Fig. 72 and in front view in Fig. 73, extends through the trigger slot in the sear and is pinned to the sear by the TRIGGER PIN, shown in Fig. 74. The trigger consists of a serrated *finger piece* A, bearing B, heel C, trigger-pin hole D, and stop E. The bearing and heel operate to give successive cam actions on a bearing formed on the receiver, so that the trigger action is divided into well-defined slack and creep.

The REAR SIGHT is mounted on the receiver over the well. The LEAF, as viewed when laid, is shown in plan in Fig. 75, in rear elevation in Fig. 76, and in side elevation in Fig. 77. It comprises the *joint bolt hole A*, the *detent faces B*, the *battle peep sight C*, and the *stop-screw hole D*. The leaf is pivoted on the JOINT BOLT, which, with its NUT, is shown in Fig. 78. The leaf is held raised or laid by means of the REAR SIGHT BASE SPRING, shown in plan in Fig. 79 and in side elevation in Fig. 80. This spring has a *hole E* to receive the REAR SIGHT BASE SPRING SCREW, shown in Fig. 81, and has *lips F* to enter undercuts in the spring seat. Its *free end G* coacts with the detent faces B on the leaf and has a *slot H* to give clearance for the battle peep sight C, should the leaf be struck back. The groove in the free end G holds the leaf at 45°, a convenient position for adjusting the slide.

The SLIDE is vertically adjustable on the leaf and is shown in plan in Fig. 82 and elevation in Fig. 83. It includes the *peep sight A*, *leaf slot B*, *indices C*, *catch-pin hole D*, and *spring retaining lug E*. Its removal from the leaf is prevented by the REAR SIGHT SLIDE STOP SCREW shown in Fig. 84. The slide is retained in adjustment by the REAR SIGHT SLIDE CATCH, Fig. 85, which is pivoted on the REAR SIGHT SLIDE CATCH PIN, Fig. 86, and is urged by the REAR SIGHT SLIDE CATCH SPRING, Fig. 87, into engagement with properly spaced notches on the edge of the leaf. The rear sight slide catch spring is seated in the *spring recess* (not shown) in the catch and is held by the spring retaining lug E on the slide. The face of the slide is checked to prevent reflection of light, which would interfere with aiming. The numbers on the leaf indicate hundreds of yards. The notches are at 100-yard intervals from 200 to 900 yards, and at 50-yard intervals from 900 to 1,600 yards.

The STOCK is shown in top view in Fig. 88 and in side view in Fig. 89. The parts are the *butt A*; *small B*; *pistol grip C*; *magazine well D*; *barrel bed E*; *air chambers F*, which reduce the charring effect of a heated barrel; *seat for butt-plate tang G*; *seat for butt-swivel plate H*; *mortise for receiver tang I*; *mortise for safety lock J*; *mortise for sear and trigger slot K*; *mortise for recoil lug L*; *grasping grooves M*; *shoulder for lower band N*; *shoulder for upper band O*; *hole for stock bolt P*; *hole for stock pin Q*; *hole for lower band pin R*. The *hole S* in the butt is for the combination oiler and thong case.

The REAR HAND GUARD is shown in elevation in Fig. 90 and in bottom or inside view in Fig. 91. It has the *rear tenon A*, to receive the hand guard ring; the *front shoulder B*, against which the lower band seats; the *rear liner seat C* and the *middle liner seat D*.

The FRONT HAND GUARD is shown in plan in Fig. 92 and in bottom or inside view in Fig. 93. It has, at its rear end, the *front liner seat E* and at its front end the *front tenon F*, which enters an undercut in the upper band.

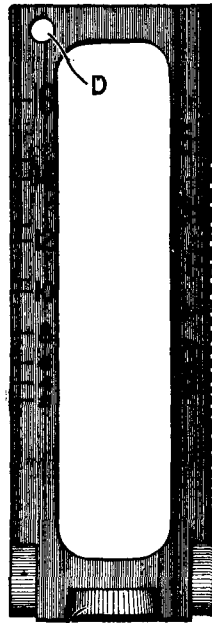

FIG. 75
C

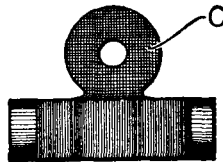

FIG. 76

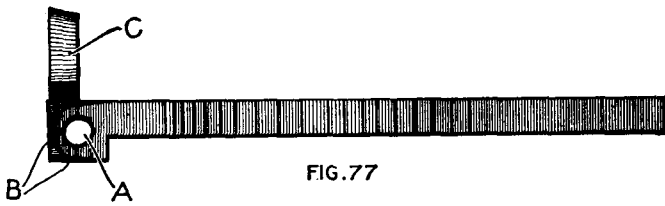

FIG. 77



FIG. 78

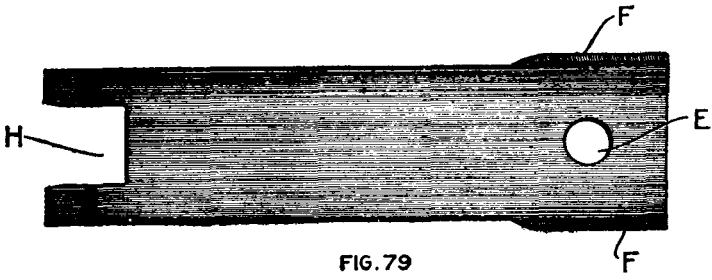

FIG. 79



FIG. 80



FIG. 81



FIG. 84

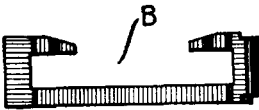

FIG. 82



FIG. 86

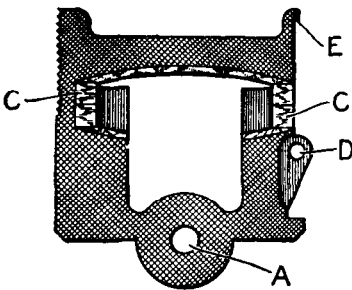

FIG. 83



FIG. 85

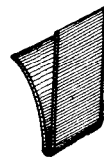

FIG. 87

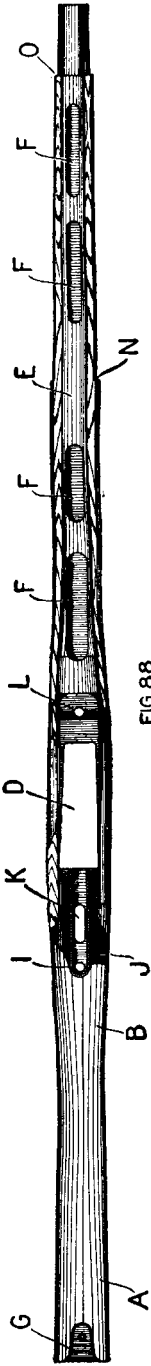

FIG. 88

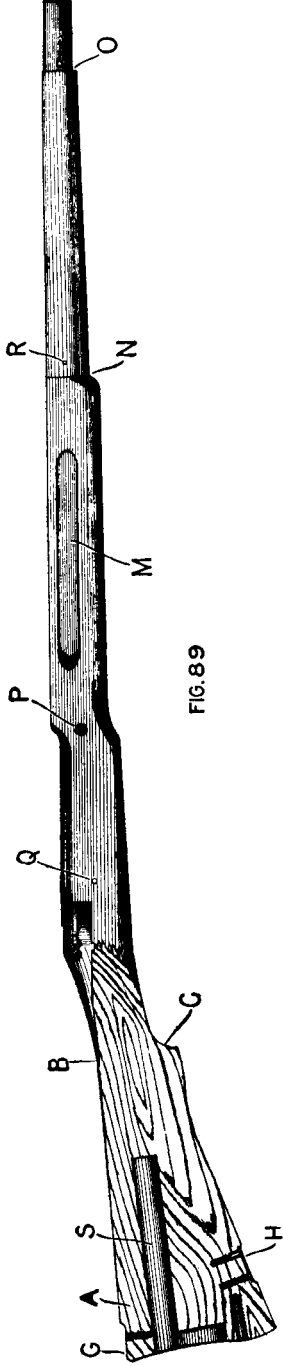

FIG. 89

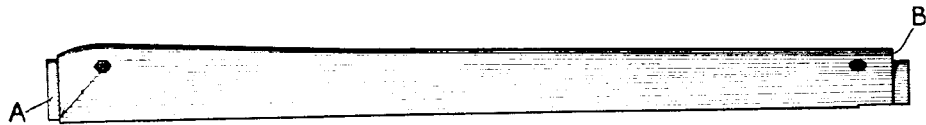

FIG. 90

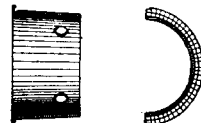

FIG. 94

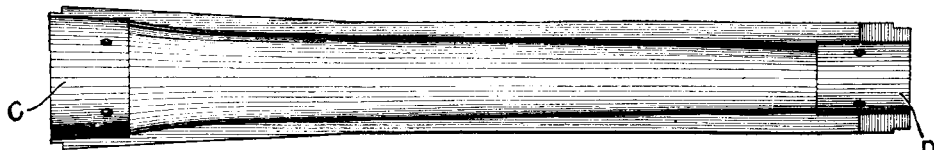

FIG. 91



FIG. 95

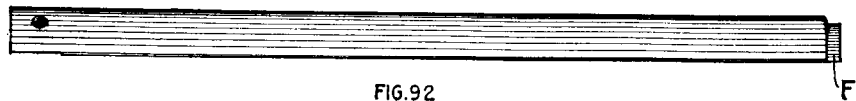

FIG. 92



FIG. 96



FIG. 97



FIG. 93

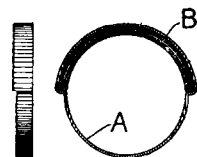

FIG. 98

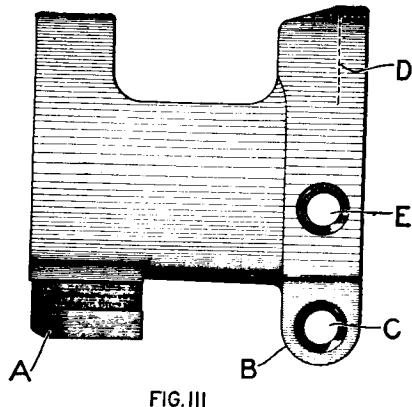
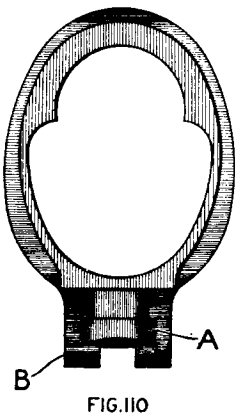
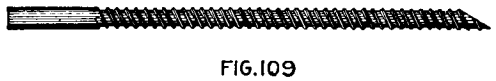
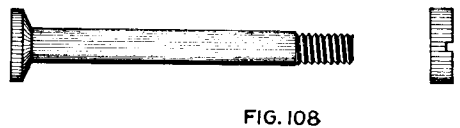
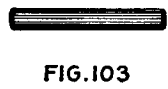
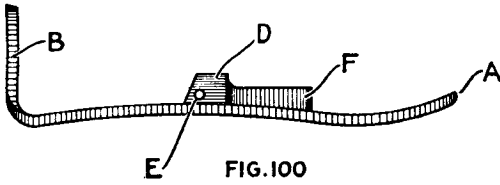
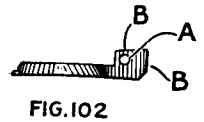
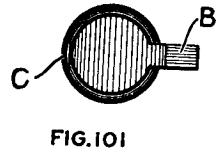
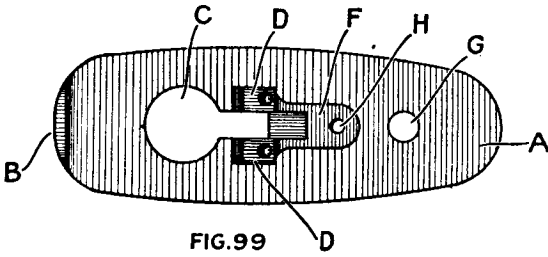



FIG. 112



FIG. 113

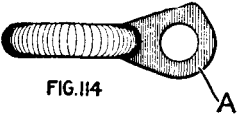

FIG. 114

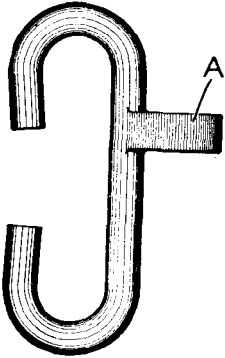

FIG. 115

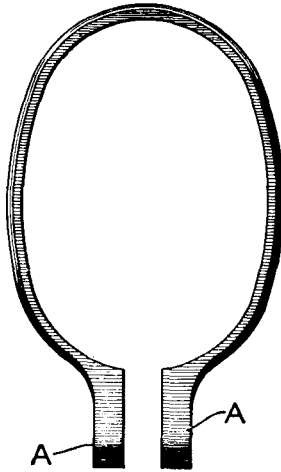

FIG. 116

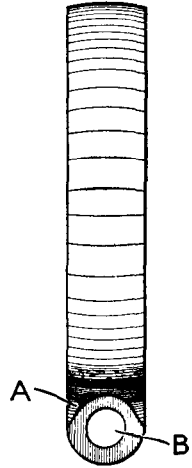

FIG. 117

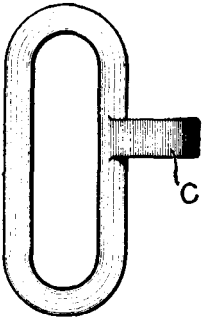

FIG. 118

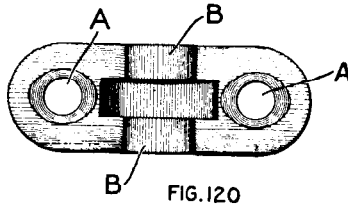

FIG. 120

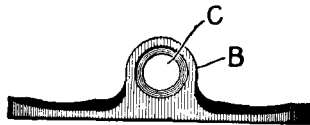

FIG. 121



FIG. 119



FIG. 122

The REAR HAND GUARD LINER is shown in bottom view and section in Fig. 94, and is mounted in the seat C of the rear hand guard. The MIDDLE HAND GUARD LINER, shown in bottom view and section in Fig. 95, is mounted in seat D. The FRONT HAND GUARD LINER, shown in bottom view and section in Fig. 96, is seated in seat E. The three hand guard liners are attached to their respective guards by the HAND GUARD RIVETS, Fig. 97.

The HAND GUARD RING is shown in side and front elevations in Fig. 98. It includes the *barrel loop* A and the *guard seat* B. The rear tenon of the rear hand guard is held in this guard seat. The front tenon of the front hand guard enters an undercut in the upper band. The adjacent ends of the two guards abut, and the joint is lapped by the lower band.

The BUTT PLATE is shown in top view in Fig. 99 and side view in Fig. 100. The parts are the *toe* A; *tang* B; *cap hole* C; *cap ears* D, through which are the *pin holes* E; the *spring lug* F; *hole for large butt-plate screw* G; and *hole for butt-plate spring screw* H. Some manufacturers form the ears integrally with the butt plate; others rivet them in place. There is a hole in the tang for the small butt plate screw.

The BUTT PLATE CAP is shown in inside view in Fig. 101 and in side view in Fig. 102. It has the *pin hole* A, *detent faces* B; and *thumb notch* C; and is pivoted between the ears on the butt plate by the BUTT PLATE PIN, Fig. 103, which is riveted in place. The cap is impositively latched in open and closed positions, by the BUTT-PLATE SPRING, Fig. 104, held by the BUTT-PLATE SPRING SCREW, Fig. 105, and bearing against the detent faces B.

The BUTT-PLATE SCREWS, LARGE and SMALL, are shown in Figs. 106 and 107, respectively. The small screw goes through the hole in the tang.

The STOCK BOLT AND NUT are shown in Fig. 108. The bolt extends transversely through the stock, just to the rear of the recoil lug on the receiver (see P, Fig. 89).

The STOCK PIN, Fig. 109, is a threaded pin, of brass, screwed through a transverse hole in the stock, between the magazine well and the trigger slot (see Q, Fig. 89). Its ends are cut off flush with the sides of the stock.

The UPPER BAND shown in end and side elevation, respectively, in Figs. 110 and 111 has the *bayonet lug* A; *ears* B, in which are the *holes* C for the STACKING-SWIVEL SCREW, Fig. 112; an *undercut* D for the front tenon of the hand guard; and the *upper band screw hole* E to receive the UPPER BAND SCREW shown in Fig. 113.

All swivel screws (Fig. 112) have hollow ends which are expanded by the use of a special expanding tool to prevent their becoming loosened.

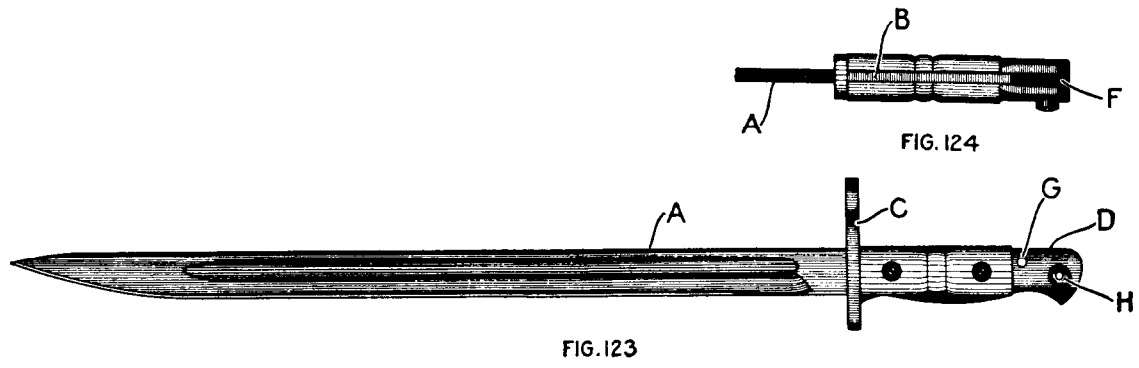

FIG. 123

FIG. 124

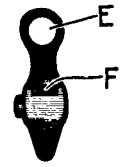

FIG. 125

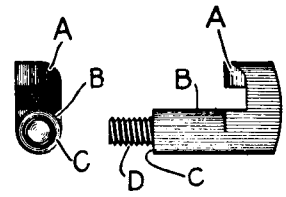

FIG. 126

FIG. 127



FIG. 131

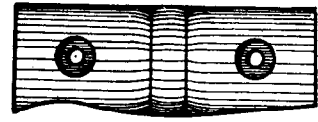

FIG. 132

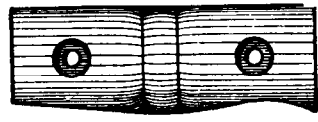

FIG. 133



FIG. 134

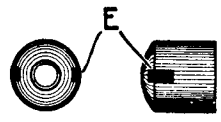

FIG. 128



FIG. 129

FIG. 130

The STACKING SWIVEL is shown in edge and top views, respectively, in Fig. 114 and Fig. 115. It is mounted with its *lug* A between the ears in the upper band, and swivels on the stacking swivel screw above mentioned.

The LOWER BAND, Figs. 116 and 117, has the *ears* A and *holes* B. The LOWER BAND SWIVEL, Fig. 118, has an offset *lug* C which lies between the ears A, and swivels on a screw identical with the stacking-swivel screw, Fig. 112.

The lower band is retained by the LOWER BAND PIN, Fig. 119, which passes through the stock (see R, Fig. 89).

The BUTT-SWIVEL PLATE, Figs. 120 and 121, has the *screw holes* A; *ears* B and *swivel screw holes* C. A swivel and swivel screw, identical with those used in the lower band (Figs. 112 and 118), are used with the butt-swivel plate. The butt-swivel plate is attached to the butt by two BUTT-SWIVEL PLATE SCREWS, Fig. 122.

THE BAYONET, MODEL 1917, AND BAYONET SCABBARD.

The BAYONET is shown in side view in Fig. 123, fragmentary rear edge view in Fig. 124 and top view in Fig. 125.

The *blade* A and *tang* B are forged in one piece; the *guard* C is forced on to the blade, and brazed in place, and the *pommel* D is brazed in place so that these parts practically form a single piece. The guard C is formed with the *barrel ring* E, to surround and thus engage the end of the rifle barrel. The pommel D has a T-shaped *stud slot* F to receive the bayonet stud, on the upper band of the rifle. The *clearing hole* G leads to the end of the stud slot and facilitates the removal of dirt or other obstructions.

The BAYONET CATCH is located at H, Fig. 123, and is illustrated in detail in Figs. 126 and 127, which are end and side elevations, respectively. It includes the *latch* A; *body* B; *shoulder* C; and *threads* D.

The CATCH THUMB PIECE, shown in outer end view in Fig. 128, side view in Fig. 129, and inner end view in Fig. 130, screws on to the threads D of the catch, and seats against the shoulder C. It has the *turning slots* E, and *spring seat* F to receive the end of the BAYONET CATCH SPRING, Fig. 131. This spring surrounds and partially guides the body B of the catch, and serves to hold the catch in engaging position, with the thumb piece protruding from the pommel. The catch is released by pressing the thumb piece.

Two counterpart GRIPS (right and left), Figs. 132 and 133, are mounted on the tang, between the pommel and guard, and are held by the BAYONET SCREWS AND NUTS shown in Fig. 134. The grips are counterbored, as shown, to receive the nuts and the heads of the screws.

The marking of bayonets taken over while in course of manufacture for the British Government, includes a canceled British property mark. On the blade, at the guard, on the same side with this, are

the letters "U. S." and the inspector's marks. On the reverse side is "1913" (the British designation of this model), numbers representing the month and year of manufacture, and the maker's name.

Bayonets of later manufacture bear on one side of the blade at the guard the Ordnance escutcheon, the inspector's marks and the letters "U. S." On the reverse side is "1917" (the official U. S. designation of this model) and the maker's name. The bayonets are not serially numbered.

The BAYONET SCABBARD, model of 1917, is shown in side elevation in Fig. 135 and edge view in Fig. 136.

The *body* A is made of sole leather, flesh side out, stitched up the inner side, and painted olive drab. The *ferrule* B and *mouthpiece* C are of sheet steel, browned. The *hanger* D is of russet leather and carries the *double hook* E by which the scabbard is attached to either the pack or the belt. The bayonet is retained in the scabbard by spring fingers (not shown) mounted in the mouthpiece, and serving frictionally to engage the blade.

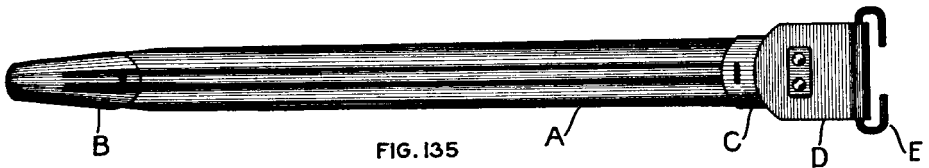

FIG. 135



FIG. 136

APPENDAGES.

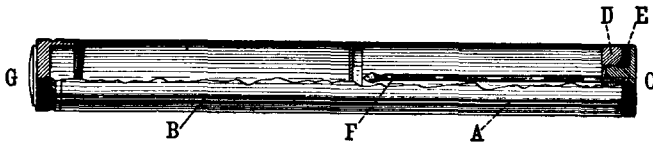

Fig. 137.

The OILER AND THONG CASE, Fig. 137, furnished for every rifle, is carried in the butt of the stock. It consists of a sand blasted and nicked brass tube, about 6 inches long and $\frac{3}{4}$ inch in diameter, divided transversely, near the center, by a partition, with both ends fitted with screw caps. In one section is carried a small supply of sperm oil, and in the other the thong and thong brush used for cleaning the bore of the rifle. The cap on the oil section is fitted with a wire, flattened at its point, which reaches to the bottom of the section and is used for applying oil, a drop or more at a time. *The oil is only for the lubrication of working parts.* The cap is also provided with a leather washer to prevent leakage. The cap

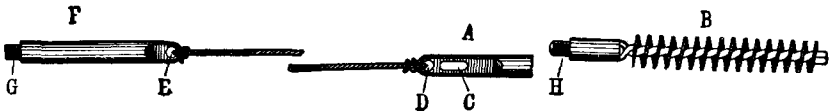

Fig. 138.

on the thong section has a leather pad on its outer surface, which prevents the noise that would result from the oiler striking the butt-plate cap. The oiler should always be inserted in the stock so that the leather-tipped cap will be next to the butt plate cap. The parts as shown in cut are: *Thong case body A and B; oiler collar D*, into which the cap is screwed; *oiler cap washer E; oil dropper C and F*, and *thong case cap G*.

The THONG AND THONG BRUSH are shown in Fig. 138. The *thong tip A*, into which the *thong brush B* is screwed, is provided with a *rag slot C*; the *thong cord* is knotted in the *hole D* in the tip, and also in the *hole E* in the weight. In cleaning the bore by means of the thong, the brush or rag should always be drawn from the muzzle toward the breech.

ACCESSORIES.

The SCREW-DRIVER, Fig. 139, has the *large blade* A, the *small blade* B, the *spur* C, the *pin* D, and the *rivet* E. The large blade should be used for the large butt-plate screw, the butt-plate spring screw, and the guard screws; the small blade for all other screws,

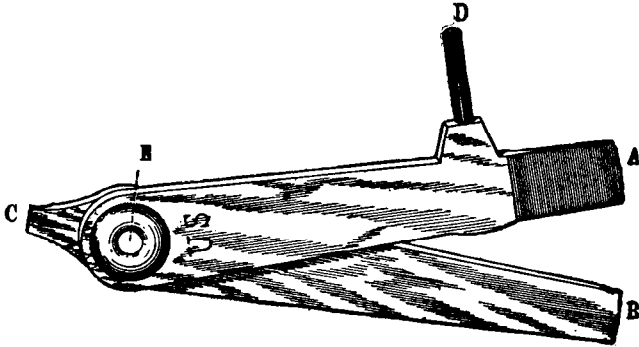

Fig. 139.

except the rear sight slide stop screw, for which the spur should be used. The pin serves as a drift in removing the butt-plate cap, floor-plate catch, and sear and trigger pins.

The BARRACK CLEANING ROD, model of 1916, Fig. 140, is made of brass rod, 0.25 inch in diameter and of sufficient length so that the bore can be cleaned from the breech end. It has the *knob* A, the *steel collar* B, and a *brass sleeve* C riveted on the end of the rod. The knob swivels on the rod between the collar and the sleeve. The other end has a socket for connection with the thong brush issued with the rifle. This rod is intended for use in garrison and camp service.



Fig. 140.

The CLEANING ROD, model of 1916, supersedes the cleaning rod, model of 1913, although the latter will be issued until the supply is exhausted. Unserviceable cleaning rods, model of 1913, are used partly in the manufacture of the model of 1916 rod and should be turned in to the commanding officer, Springfield Armory, by proper authority for this purpose.

The **NEW ROD** is a jointed brass rod, 0.25 inch in diameter and 36.187 ($36\frac{3}{16}$) inches long. It is made in four sections; the handle section with knob, Fig. 141; the second section, Fig. 142; the third section, Fig. 143; and the brush section, Fig. 144, to which is attached the thong brush issued with the rifle.



Fig. 141.



Fig. 142.



Fig. 143.



Fig. 144.

Each rod is packed in a case of olive-drab webbing and rods are issued on the basis of one for each eight rifles.

This rod and case are intended for use in field service only.

FOLLOWER DEPRESSOR.

The **FOLLOWER DEPRESSOR** is shown in perspective in Fig 145. It is used to hold the follower down, clear of the bolt, so that the rifle may be used for drill purposes in simulating fire. It comprises the *top plate A*; *wings B*; and *finger notch C*. The follower is forced

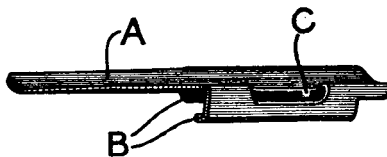

FIG. 145

down and the depressor is slipped into the magazine edgewise above the follower and is then turned so that its edges engage under the sides of the magazine opening in the receiver. Since the top plate is troughed, full clearance for the movement of the bolt is given. To remove the depressor, it is pushed down and tipped laterally by inserting the point of a bullet in notch C. When so tipped, it will be lifted out of the magazine by the follower.

ACTION OF THE MECHANISM.

(Refer to Figs. 146 and 147.)

Suppose that a cartridge has just been fired. By raising the bolt handle, the bolt is rotated to the left. Since the cocking-piece lug is held against turning by the cocking-piece groove, it is forced to the rear in the bolt by the half-cocking cam, and engages the half-cock notch. This action withdraws the striker into the bolt. As soon as the locking lugs on the bolt clear the locking cams and the safety lug on the bolt handle clears the safety lug on the receiver, the extracting cams on the bolt and receiver engage and coact during continued rotation of the bolt, to retract the latter and thus provide primary extraction. During the rotation of the bolt, the extractor is prevented from turning, by guides provided in the receiver for that purpose. Similarly, the sleeve is held against rotation by engagement with the receiver.

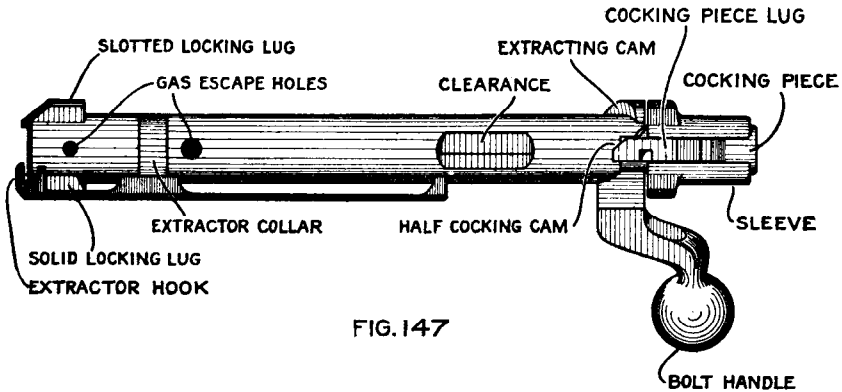

FIG. 147

The limit of turning movement of the bolt finds the locking lugs in a horizontal position. The bolt is then drawn straight to the rear, the extractor continuing to withdraw the empty cartridge case.

As the bolt begins to travel backward, the cocking piece rides over the sear nose and depresses it, the safety stud rising into the clearance provided therefor on the bolt. When the cocking piece clears the sear nose, this is raised to normal position by the sear spring.

When the rear face of the slotted (now left hand) locking lug reaches the ejector, the latter is forced into the slot in the lug and protruding through the same, in its further rearward movement, strikes the rear of the empty case and ejects it to the right. Shortly before ejection, the bolt clears the rear end of the top cartridge in the magazine, which is forced up by the magazine spring into the path of the lower edge of the bolt. If there be no cartridge in the magazine, the

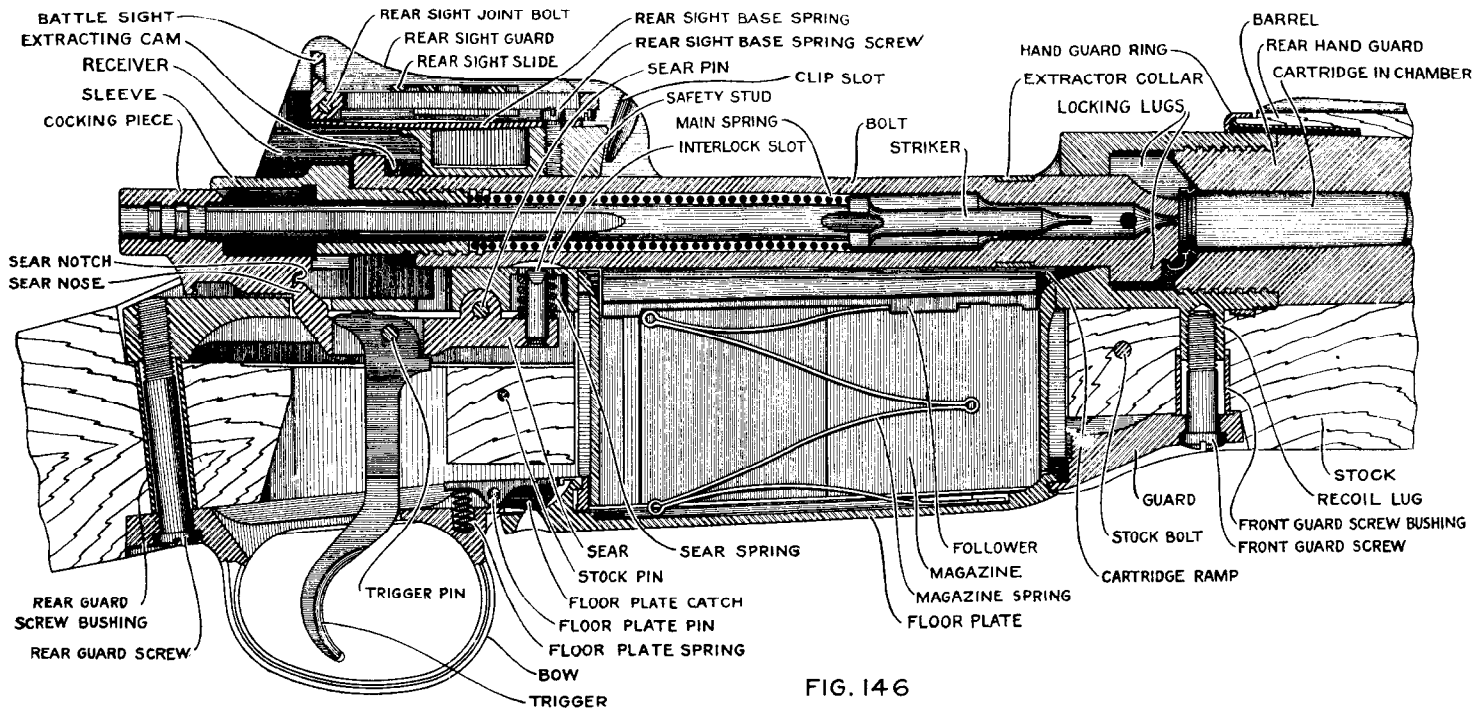

FIG. 146

follower rises so that its rib will prevent the closing movement of the bolt. This warns the soldier that his magazine is empty.

After a slight further backward movement of the bolt, this is arrested by collision of the slotted locking lug with the bolt stop lug.

Assuming that the magazine contains one or more cartridges, the forward movement of the bolt forces the topmost cartridge forward and up over the cartridge ramp. The groove in the case engages the extractor as the cartridge rises.

During the early part of the closing movement of the bolt, the ejector is pushed outward by the side of the bolt. Later, the sear notch in the cocking piece engages the sear nose, and is arrested. The bolt then slides forward over the striker, further compressing the main spring.

When the rotation of the bolt by the handle begins, the locking lugs engage the locking cams, and force the bolt home, seating the cartridge with considerable pressure, and further compressing the main spring. The rotation of the bolt restores the half cocking cam, so that it is out of the path of fall of the cocking piece lug.

The bolt is now locked, the main spring is fully compressed, and the cocking piece is held by the sear nose.

When the trigger is squeezed, the bearing of the trigger first acts on the bearing of the receiver, slowly depressing the sear nose and giving the slack. Then the heel of the trigger engages the receiver, and completes the depression of the sear nose, giving the movement known as the creep, which ends in the release of the cocking piece by the sear nose. The striker then falls under the action of the main spring, and, striking the primer of the cartridge, detonates the same.

During the depression of the sear nose, the safety stud rises through its hole in the bottom of the well, and enters the interlock slot in the bolt. If the bolt is not fully locked, the interlock slot will not register with the safety stud, and the trigger can not be pulled.

When the pressure on the trigger is relaxed, the sear spring restores the sear and trigger to normal position.

MANIPULATION BY SOLDIER.

To load.—Raise the bolt handle, and draw the bolt straight to the rear, to the limit of its motion. Place either end of a loaded clip in the clip slots in the receiver, and, with the thumb of the right hand, push the cartridges down into the magazine until the top cartridge is caught by the right edge of the receiver. Then close the bolt, and lock it by turning the handle down. The forward movement of the bolt carries the topmost cartridge into the chamber, and ejects the clip. The rifle is now ready to be fired by pulling the trigger.

Clips hold five cartridges, which is the capacity of the magazine, but a sixth cartridge may be carried in the chamber, *if the cartridges in the magazine be pressed down and the bolt be started forward over them before inserting the additional cartridge into the chamber.* Care must be taken to see that the bolt is safely started forward over the top cartridge, as the feeding of a second cartridge into the chamber by the bolt may result in the detonation of the first cartridge by the nose of the second while the bolt is open.

To eject the empty case of a fired cartridge, feed a new cartridge from the magazine into the chamber, and cock the piece, the bolt is unlocked, drawn fully to the rear, closed and locked. If the magazine is empty, the bolt will be locked in its open or rear position, by the rising of the follower.

To render the piece safe when loaded, turn the safety lock to the rear.

PRECAUTIONS.

If it is desired to carry the piece cocked, with a cartridge in the chamber, the safety lock should be turned to the rear. *Under no circumstances* should an attempt be made to let the firing pin down by hand, or by a manipulation of the trigger while closing the bolt, upon a cartridge in the chamber.

To obtain positive action, the bolt, when actuated, should be drawn fully to the rear.

If the rifle misses fire, the bolt should not be opened or unlocked until sufficient time has elapsed to assure that the cartridge is not hanging fire. Inasmuch as the rifle can not be cocked except by opening the bolt, there will be a temptation to open the bolt too soon, and it is wise to wait even a full minute and be sure.

All cams and working parts should be kept oiled to avoid undue wear.

DISMOUNTING AND ASSEMBLING BY SOLDIERS.

To dismount the bolt.—Remove the bolt from the rifle by drawing it out to the rear while pulling out the thumb piece of the bolt stop. Hook a loop of string on the dismounting hook on the cocking-piece lug, and, holding the bolt in the left hand and the string in the right, draw the cocking piece out until the lug clears the end of the bolt. (See fig. 148.) Then, by moving the right hand in a circular path counterclockwise, unscrew the sleeve from the bolt and withdraw the sleeve, cocking piece and striker from the bolt. Grasp the sleeve with the left hand, and, while holding the point of the striker against a wood or similar surface, force the sleeve toward the point of the striker, compressing the mainspring until the lug on the cocking piece clears the lug slot in the sleeve, as shown in Fig. 149. Then, with the right hand, give the cocking piece a quarter turn, in either direction, to disengage it from the striker, and draw it off to the rear. Relieve the spring

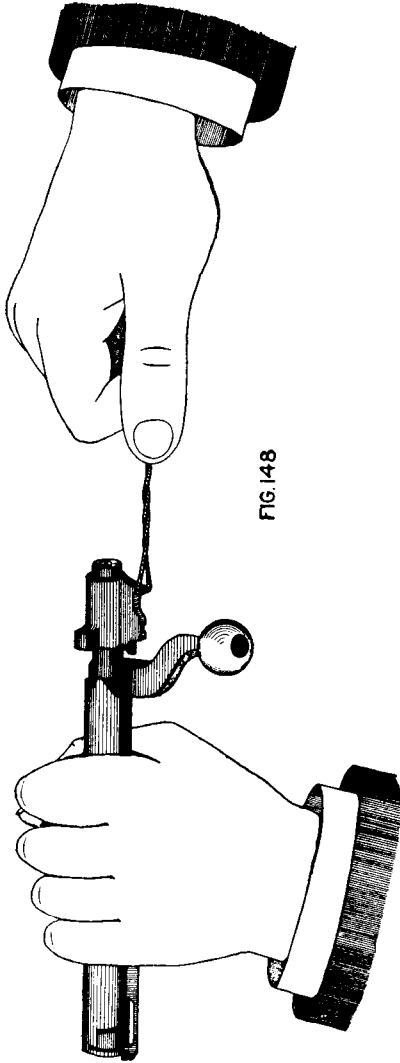

FIG. 148

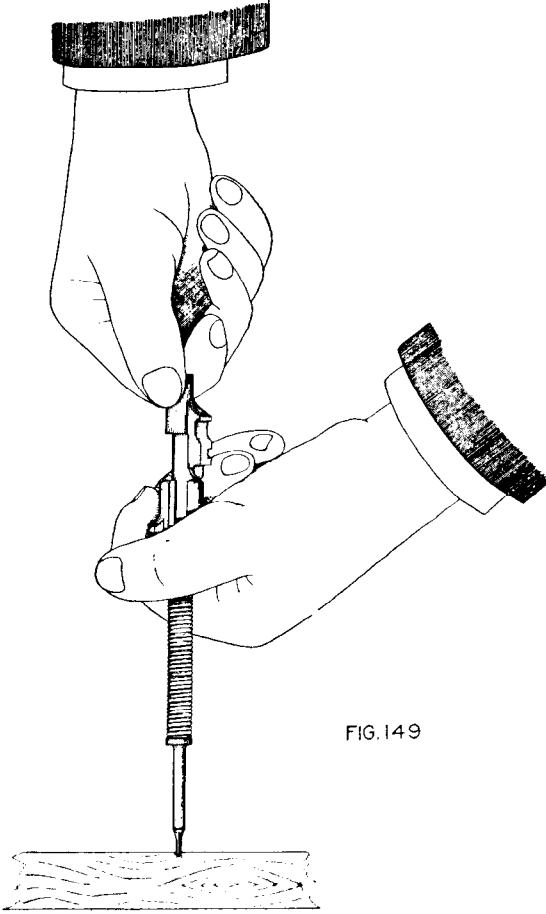

FIG. 149

from stress slowly and remove it and the sleeve from the striker, being careful that the parts do not fly from the hand. Turn the extractor so that it covers the gas escape holes in the bolt and push it forward with the thumb until it is free of the ears on the collar.

To assemble the bolt.—Slide the mainspring over the striker. Hold the point of the striker against a wood or similar surface, and, placing the sleeve against the end of the spring, with the flats in its bore registering with the flats on the striker, compress the spring by forcing the sleeve toward the point of the striker. Holding the sleeve with the spring fully compressed, replace the cocking piece on the end of the striker and lock it by a quarter turn so that its lug aligns with the lug-slot in the sleeve. Then let the sleeve return to position slowly under the action of the spring. Grasp the bolt in the left hand and start the threads on the barrel of the sleeve into the threads in the end of the bolt. Holding a loop of string in the right hand as before, hook it on the dismounting hook, and draw the cocking piece out. Then, by moving the right hand in a circular path, clockwise, screw the sleeve home in the bolt. Place the lug in the half-cock notch. Slide the extractor to place in line with the gas escape holes, engaging the undercut lug on the extractor with the ears on the ring, and lifting the hook so that the tongue will slide over the end of the bolt. Turn the extractor so that it lies over the unslotted or solid lug, and replace the bolt in the receiver. Push the follower down and close and lock the bolt.

To dismount the magazine mechanism.—With the bullet end of a cartridge, press the floor-plate catch (through the hole in the floor plate), and, at the same time, draw the floor plate to the rear. This releases the floor plate, which comes out, bringing with it the follower and follower spring.

The spring may be released from the floor plate and follower, by springing it to clear the spring stops and then withdrawing its ends from the undercuts.

To assemble the magazine mechanism.—Connect the magazine spring with the follower and floor plate by inserting its ends in the spring seats therein.

Insert the follower and spring into the magazine, and put the tenon on the front end of the floor plate in place. Then seat the floor plate by pressing it inward and forward, so that the lug on the floor plate enters its slot in the guard and is latched by the magazine catch.

The foregoing dismounting operations are the only ones to be performed by the soldier.

Selected men, properly trained, and acting under proper authority, may perform such further dismounting operations as may be necessary for repairs, proceeding as follows.

TO COMPLETE DISMOUNTING.

(Not to be done by soldier.)

The bolt and magazine having been dismantled proceed as follows:

1. Remove the screws from the upper and lower bands, and move them forward until clear of hand guards and stock; then remove upper and lower hand guards.

2. Remove the front and rear guard screws, and remove guard and magazine.

3. Remove the barrel and receiver from stock.

4. Remove the stock bolt.

5. Remove the butt swivel plate screws, and remove the butt swivel plate.

6. Unscrew butt plate screws, and remove butt plate from stock.

7. Unscrew butt plate spring screw, and remove the butt plate spring; drive out butt plate pin, and remove butt plate cap.

8. Remove the bolt stop and ejector by unscrewing the bolt stop screw. The bolt stop and ejector can then be disengaged.

9. Remove the bolt stop spring rest.

10. Unscrew safety lock holder screw, and remove holder; turn the thumb piece of the safety lock down and withdraw the safety lock from its housing. The plunger and spring can then be removed.

11. Remove sear and trigger by driving out sear pin (from the right), being careful not to lose sear spring.

12. Remove trigger from sear by driving out trigger pin from either side.

13. Drive front sight out from left, using drift and light hammer.

14. Drive out front sight carrier pin, and force the carrier off the end of barrel, using a hardwood block and hammer.

15. Remove upper and lower bands, also hand guard ring.

TO ASSEMBLE AFTER DISMOUNTING.

Reverse and follow in inverse order, the operations of dismantling.

The sear and trigger, bolt stop and safety lock should be assembled to the receiver before placing the latter in the stock.

The upper and lower bands and hand guard ring must be slipped over the muzzle before the front sight carrier is forced on.

CLEANING THE RIFLE.

The proper care of the bore requires conscientious, careful work, but it pays well in reduced labor of cleaning and in prolonged accuracy-life of the barrel, and better results in target practice. Briefly stated, the care of the bore consists in removing the fouling resulting from firing, to obtain a chemically clean surface, and coating this surface with a film of oil to prevent rusting. The fouling which results from

firing is of two kinds—one, the products of combustion of the powder; the other, cupro-nickel scraped off (under the abrading action of irregularities or grit in the bore). Powder fouling, because of its acid reaction, is highly corrosive; that is, it will induce rust and must be removed. Metal fouling of itself is inactive, but may cover powder fouling and prevent the action of cleaning agents until removed, and when accumulated in noticeable quantities it reduces the accuracy of the rifle.

Powder fouling may be readily removed by scrubbing with hot soda solution, but this solution has no effect on the metal fouling of cupro-nickel. It is therefore necessary to remove all metal fouling before assurance can be had that all powder fouling has been removed and that the bore may be safely oiled. Normally, after firing a barrel in good condition, the metal fouling is so slight as to be hardly perceptible. It is merely a smear of infinitesimal thickness, easily removed by solvents of cupro-nickel. However, due to pitting, the presence of dust, other abrasives, or to accumulation, metal fouling may occur in clearly visible flakes or patches of much greater thickness, much more difficult to remove.

In cleaning the bore after firing, it is well to proceed as follows: Swab out the bore with soda solution (see below) to remove powder fouling. A convenient method is to insert the muzzle of the rifle into the can containing the soda solution and, with the cleaning rod inserted from the breech, pump the barrel full a few times. Remove and dry with a couple of patches. Examine the bore to see that there are in evidence no patches of metal fouling which, if present, can be readily detected by the naked eye, then swab out with the swabbing solution—a dilute metal-fouling solution. (See below.) The amount of swabbing required with the swabbing solution can be determined only by experience and by observation of the color of the patches. Swabbing should be continued as long as the wiping patch is discolored by a bluish-green stain. Normally a couple of minutes' work is sufficient. Dry thoroughly and oil.

The proper method of oiling a barrel is as follows: Wipe the cleaning rod dry; select a clean patch and thoroughly saturate it with sperm oil or warmed cosmic, being sure that the cosmic has penetrated the patch; scrub the bore with the patch, finally drawing the patch smoothly from the muzzle to the breech, allowing the cleaning rod to turn with the rifling. The bore will be found now to be smooth and bright, so that any subsequent rust and sweating can be easily detected by inspection.

If patches of metal fouling are seen upon visual inspection of the bore, the standard metal-fouling solution prepared as hereinafter prescribed must be used. After scrubbing out with the soda solution, plug the bore at the breech with a cork at the front end of the cham-

ber, or where the rifling begins. Slip a 2-inch section of rubber hose over the muzzle down to the sight and fill with the standard solution to at least one-half inch above the muzzle of the barrel. Let it stand for 30 minutes, pour out the standard solution, remove hose and breech plug, and swab out thoroughly with soda solution to neutralize and remove all trace of ammonia and powder fouling. Wipe the barrel clean, dry, and oil. With few exceptions, one application is sufficient, but if all fouling is not removed, as determined by careful visual inspection of the bore and of the wiping patches, repeat as described above.

After properly cleaning with either the swabbing solution or the standard solution, as has just been described, the bore should be clean and safe to oil and put away, but as a measure of safety a patch should *always* be run through the bore on the next day and the bore and wiping patch examined to insure that cleaning has been properly accomplished. The bore should then be oiled, as described above.

If the swabbing solution or the standard metal-fouling solution is not available, the barrel should be scrubbed, as already described, with the soda solution, dried, and oiled with a light oil. At the end of 24 hours it should again be cleaned, when it will usually be found to have "sweated"; that is, rust having formed under the smear of metal fouling where powder fouling was present, the surface is puffed up. Usually a second cleaning is sufficient, but to insure safety it should be again examined at the end of a few days before final oiling. The swabbing solution should always be used, if available, for it must be remembered that each puff when the bore "sweats" is an incipient rust pit.

A clean dry surface having been obtained, to prevent rust, it is necessary to coat every portion of this surface with a film of neutral oil. If the protection required is but temporary and the arm is to be cleaned or fired in a few days, a sperm oil may be used. This is easily applied and easily removed but has not sufficient body to hold its surface for more than a few days. If rifles are to be prepared for storage or shipment, a heavier oil, such as cosmic, must be used.

In preparing arms for storage or shipment they should be cleaned with particular care, using the metal-fouling solution as described above. Care should be taken, insured by careful inspection on succeeding day or days, that the cleaning is properly done and all traces of ammonia solution removed. The bore is then ready to be coated with cosmic. At ordinary temperatures cosmic is not fluid. In order, therefore, to insure that every part of the surface is coated with a film of oil, the cosmic should be warmed. Apply the cosmic first with a brush; then, with the breech plugged, fill the barrel to the muzzle, pour out the surplus, remove the plug, and allow to drain.

It is believed that more rifles are ruined by improper preparation for storage than from any other cause. If the bore is not clean when oiled—that is, if powder fouling is present or rust has started—a half inch of cosmic on the outside will not stop its action, and the barrel will be ruined. Remember that the surface must be perfectly cleaned before the heavy oil is applied. If the instructions as given above are carefully followed, arms may be stored for years without harm.

PREPARATION OF SOLUTIONS.

Soda solution.—This should be a saturated solution of sal soda (carbonate of soda). A strength of at least 20 per cent is necessary. The spoon referred to in the following directions is the model of 1910 spoon issued in the mess outfit.

Sal soda—one-fourth pound, or 4 (four) heaping spoonfuls.

Water—1 pint or cup, model of 1910, to upper rivets.

The sal soda will dissolve more readily in hot water.

Swabbing solution.—Ammonium persulphate—60 grains, one-half spoonful smoothed off.

Ammonia, 28 per cent—6 ounces, or three-eighths of a pint, or 12 spoonfuls.

Water—4 ounces, or one-fourth pint, or 8 spoonfuls.

Dissolve the ammonium persulphate in the water and add the ammonia. Keep in tightly corked bottle; pour out only what is necessary at the time, and keep the bottle corked.

Standard metal-fouling solution.—Ammonium persulphate—1 ounce, or 2 medium heaping spoonfuls.

Ammonium carbonate—200 grains.

Ammonia, 28 per cent—6 ounces, or three-eighths pint, or 12 spoonfuls.

Water—4 ounces, or one-fourth pint, or 8 spoonfuls.

Powder the persulphate and carbonate together, dissolve in the water, and add the ammonia; mix thoroughly and allow to stand for one hour before using. It should be kept in a strong bottle, tightly corked. The solution should not be used more than twice, and used solution should not be mixed with unused solution, but should be bottled separately. The solution, when mixed, should be used within 30 days. Care should be used in mixing and using this solution to prevent injury to the rifle. The ammonia solution should not be used in a warm barrel. An experienced noncommissioned officer should mix the solution and superintend its use.

Neither of these ammonia solutions has any appreciable action on steel when not exposed to the air, but if allowed to evaporate on steel they attack it rapidly. Care should, therefore, be taken that none spills on the mechanism and that the barrel is washed out promptly with soda solution. The first application of soda solution removes

the greater portion of the powder fouling and permits a more effective and economical use of the ammonia solution. These ammonia solutions are expensive and should be used economically.

It is a fact recognized by all that a highly polished steel surface rusts much less easily than one which is roughened; also, that a barrel which is pitted fouls much more rapidly than one which is smooth. Every effort, therefore, should be made to prevent the formation of pits, which are merely enlarged rust spots, and which not only affect the accuracy of the arm but increase the labor of cleaning.

The chambers of rifles are frequently neglected because they are not readily inspected. Care should be taken to see that they are cleaned as thoroughly as the bore. A roughened chamber delays greatly the rapidity of fire and not infrequently causes shells to stick.

A cleaning rack should be provided for every barracks. Rifles should always be cleaned from the breech, thus avoiding possible injury to the rifling at the muzzle which would affect the shooting adversely. If the bore for a length of 6 inches at the muzzle is perfect, a minor injury near the chamber will have little effect on the accuracy of the rifle. The rifle should be cleaned as soon as the firing for the day is completed. The fouling is easier to remove then, and if left longer it will corrode the barrel.

If gas escapes at the base of the cartridge, it will probably enter the well of the bolt through the striker hole. In this case the bolt mechanism must be dismantled and the parts and well of the bolt thoroughly cleaned.

Before assembling the bolt mechanism, the firing pin, the barrel of the sleeve, the body of striker, the well of bolt, and all cams should be lightly oiled.

Many of the parts can generally be cleaned with dry rags. All parts after cleaning should be wiped with an oiled rag.

The best method of applying oil is to rub with a piece of cotton cloth upon which a few drops of oil have been placed, thereby avoiding the use of an unnecessary amount of oil; this method will, even in the absence of the oiler, serve for the cams and bearings, which should be kept continually oiled.

Any part that may appear to move hard can generally be freed by the use of a little oil.

The stock and hand guard may be coated with raw linseed oil and polished by rubbing with the hand.

Sperm oil should be used only for lubricating metallic bearing and contact surfaces.

For the chamber and bore, only cosmoline or cosmic should be used. This should be applied also to all metallic surfaces, to prevent rusting when arms are stored or when not used for an appreciable length of time.

PACKING OF RIFLE.

The rifles are issued in arm chests containing:

Ten United States rifles, caliber .30, model of 1917.

One book, Description and Rules for the Management of the United States Rifle, caliber .30, model of 1917, Form 1917.

The interior of the arm chest is provided with wooden packing strips for the purpose of securely holding the rifles in place in transportation. The arrangement of this packing and of the rifles should be carefully observed when arms are received from an arsenal in order that the same method may be used if for any reason the rifles should be shipped away from the post. Rifles should never be shipped in these chests unless all of the packing strips have been properly assembled with the rifles in the chests.

Plate I, at the back of this pamphlet, shows the arm chest in detail.

SPARE PARTS FOR REPAIRS.

The following spare parts for rifle, bayonet, appendages, and accessories will be issued packed in chests, each chest to supply repairs for 100 rifles for one year:

RIFLE PARTS.

2 bolts assembled with extractor collars.	3 guards.
3 bolt stops.	1 guard screw bushing, front (see "stock").
5 bolt stop screws.	1 guard screw bushing, rear (see "stock").
5 bolt stop springs.	3 guard screws, front.
1 bolt stop spring rest.	3 guard screws, rear.
2 butt plates assembled (including plate, cap, pin, spring, and spring screw).	6 hand guards, front, assembled with front liner.
3 butt plate screws, large.	6 hand guards, rear, assembled with middle and rear liners.
3 butt plate screws, small.	3 hand guard rings.
Butt swivel. See swivels.	2 lower bands.
Butt swivel screw. See swivel screws.	Lower band screw. See "swivel screw."
3 butt swivel plates.	2 lower band pins.
2 butt swivel plate screws.	Lower band swivel. See "swivel."
5 ejectors.	2 magazines.
5 extractors.	6 magazine springs.
30 strikers.	4 main springs.
10 cocking pieces.	5 rear sight base springs.
3 floor plates.	3 rear sight base spring screws.
3 floor-plate catches.	4 rear sight joint bolts.
3 floor-plate pins.	4 rear sight joint bolt nuts.
6 floor-plate springs.	
2 followers.	

6 rear sight leaves assembled (including leaf, slide, slide catch, slide catch spring, slide catch, pin, slide stop screw).	2 stacking swivels.
3 safety locks.	Stacking swivel screw. See "swivel screws."
1 safety lock holder.	10 stocks (assembled with guard screw bushings, tie bolts and nuts, and stock pins).
3 safety lock holder screws.	2 swivels (for lower band and butt).
2 safety lock plungers.	3 swivel screws (for all swivels).
6 safety lock springs.	1 trigger.
3 sears.	1 trigger pin.
3 sear pins.	2 upper bands.
6 sear springs.	3 upper band screws.
3 sleeves.	

BAYONET PARTS.

2 complete bayonets.	6 bayonet grips, right.
3 bayonet catches.	6 bayonet grips, left.
5 bayonet catch springs.	4 bayonet screws.
4 bayonet catch thumb pieces.	4 bayonet screw nuts.

APPENDAGE PARTS.

3 oil droppers.	3 thong case caps and pads (assembled).
13 oiler cap washers.	20 thong cords.
3 oiler and thong cases (oiler collar, thong case body, and thong case partition assembled).	8 thong tips.
	8 thong weights.
	18 thong brushes.

ACCESSORY PARTS.

3 cleaning rods (each including handle section, knob, collar, sleeve, second section, third section, brush section).	3 cleaning rod cases.
	2 screw drivers assembled (each including large blade, small blade, pin and rivet).

PARTS WHICH ARE MOST LIABLE TO REQUIRE REPAIR.

COCKING PIECE.—Nose worn from neglect to keep it lubricated.

LOWER BAND SWIVEL AND SCREW.—Screw, if not properly expanded, works loose and, with swivel, is lost.

STACKING SWIVEL AND SCREW.—Screw, if not properly expanded, works loose and, with swivel, is lost.

STOCK.—Bruises, cuts, pieces chipped from different points, broken at small.

STRIKER.—Point burned by defective cartridge, or broken by snapping with the chamber empty.

REPLACING BROKEN PARTS.

BUTT PLATE PIN.—This pin has both ends upset; the burr on one end must be filed off and the pin driven out with a drift; when a new pin is put in, its ends must be upset with light blows of a hammer.

SWIVEL SCREWS.—These screws, upon which the stacking swivel, lower band swivel, and butt swivel are mounted, have hollow ends which are expanded to prevent the loosening of the screws. If a burr has been formed by the expanding operation it should be filed off before attempting to remove the screws. After the screw has been replaced it should again be expanded by the use of the special expanding tool provided for that purpose.

TRIGGER PIN.—This is a straight pin and can be driven in or out from either side.

INJURIES WHICH DO NOT RENDER PARTS UNSERVICEABLE.

BOLT.—The entire flange at front end may be broken off, except a small portion on the opposite side from the extractor hook, which is required to hold, in connection with the extractor hook, the empty case while it is being drawn to the rear for ejection.

If automatic ejection be not considered, the entire flange may be dispensed with.

BUTT PLATE.—Bruises, cuts, or wearing.

BUTT SWIVEL.—Bent.

COCKING PIECE.—Moderate wearing of nose. The nose can wear until manipulation of the bolt fails to cock the piece.

EXTRACTOR.—Moderate wear or break of edge of hook.

FLOOR PLATE.—Bent or bruised.

GUARD.—Bent, bruised, or cut.

USING THE RIFLE WHEN CERTAIN PARTS OF THE BOLT AND MAGAZINE MECHANISM ARE WANTING.

The parts not essential, or only so to a degree, are the ejector, safety lock, bolt stop, floor plate, magazine spring, and follower.

In the absence of the ejector, the empty cases drawn to the rear by the extractor can be removed from the receiver by the finger.

The safety lock being merely a precautionary device, its absence does not affect the usefulness of the arm.

The absence of the bolt stop does not affect the usefulness of the arm.

The absence of the floor plate, follower, and magazine spring only prevents the use of the magazine, but does not prohibit the use of the arm as a single-loader. The soldier should be taught to appreciate these facts.

REMARKS.

All cams and bearings should be kept slightly oiled to prevent wear.

When firing many successive rounds care must be taken that unburned grains of powder do not collect and pack in the locking lug recesses of the receiver, as this will interfere with the perfect closing of the bolt. Such accumulations can be blown out from time to time, or, when packed, removed by a knife or the screw driver.

Except when repairs are needed, the following parts will constantly be injured if allowed to be dismantled by the soldier for cleaning; and when repairs are necessary, they should be removed only by a company artificer, or some one familiar with the handling of tools and delicate mechanisms, viz: Bolt stop, safety lock, front sight, lower band, upper band, and stacking swivel screws.

Unless the screw driver is handled carefully, and with some skill, the screws are sure to be injured either at the head or thread.

The BULLET JACKET EXTRACTOR is shown in Figs. 150, 151, and 152. This extractor consists of a steel cylindrical plug provided with lands and grooves on the sides. To use the extractor, it is inserted in the muzzle of the barrel hollow end (see Fig. 152) first. The extractor is then urged down the barrel by pressure applied with the cleaning rod until the jacket and extractor fall out into the chamber. The bullet extractor for the 1917 rifle is different from that for the 1903 rifle and may be distinguished by the fact that it has five grooves and left-hand twist, to accord with the rifling.



FIG. 150



FIG. 151



FIG. 152

The AIMING DEVICE, shown in Fig. 153, in place on a model of 1903 rifle, and Fig. 154 in detail, is intended for use in aiming drill and is issued to infantry, cavalry, and engineers at the rate of four per company. With this device the instructor may give a visual demonstration and thereby convince the soldier of the errors made in aiming.

The device consists of *yoke* A, which by means of the *spring clips* B embraces the small of the stock, the *bracket* C to which the collap-

sible *arms D* are held, and the *eye E*, which is closed by the *shutter F*. The eye is provided with a *stop pin G*, to hold the shutter in an open

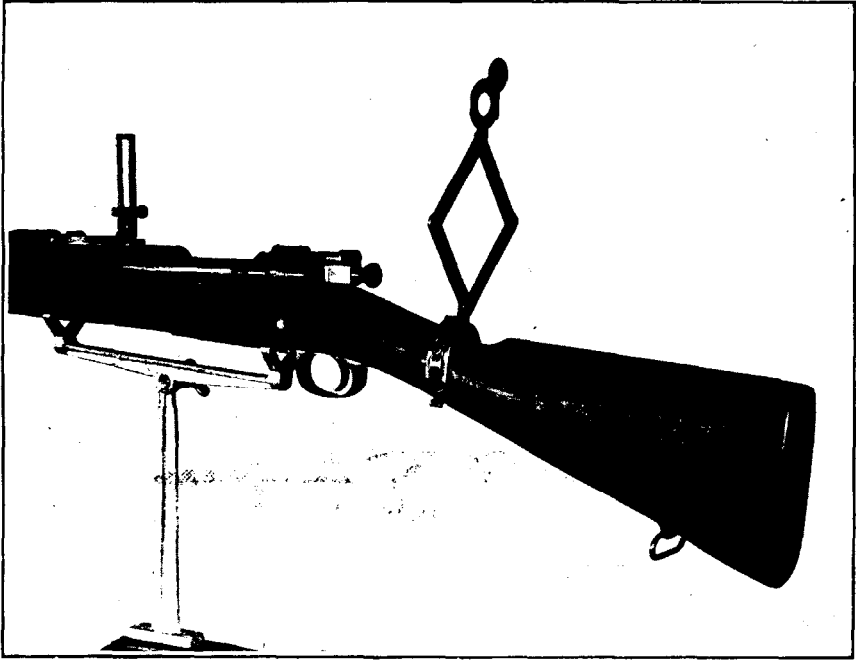

Fig. 153.

position. Tension washers are furnished for the joints to lend stiffness to the mechanism.

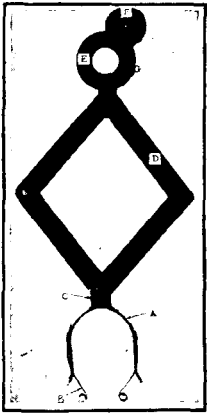

Fig. 154.

To use the device it should be seated firmly on the rifle at the small of the stock. The rifle should then be placed on an improvised rest, or aiming stand. The instructor sights the rifle very accurately, bringing the point of aim, the front sight, rear sight, and the pin hole in the *shutter F* all into line. Then he throws back the shutter of the aiming device so as to expose the large aperture in the *eye E*. He requires the recruit to verify the sight setting.

Then the instructor may change the position of the rifle either slightly or considerably and require the recruit to explain how the line of sight lies with reference to the point of aim, or if very wide of the mark he may direct him to sight

the piece and bring the line of sight back on the mark. The recruit uses only the large aperture, which is practically the same as if he did not have the aiming device at all. The instructor then drops the

shutter and shows him conclusively that he has been looking along the right or left side of the front sight, or has failed to look through the middle of the rear sight notch, or has taken a full sight when he said he was taking a half sight, etc

**AMMUNITION FOR UNITED STATES RIFLE, CALIBER .30,
MODEL OF 1917.**

BALL CARTRIDGE, MODEL OF 1906.

The CALIBER .30 BALL CARTRIDGE, Fig. 155, consists of the *case*, *primer*, *charge of smokeless powder*, and *bullet*. The case is of cartridge brass. It has a conical body joined to the neck by a sharper cone, called the shoulder. The neck is the seat of the bullet and is very nearly cylindrical. The front end of the case is called the mouth and the rear end the head. The mouth edge of the case is crimped on the bullet, when the cartridge is assembled, in order to keep the bullet secure in the case. The head of case is grooved to provide for extraction of cartridge from the chamber of the rifle and is provided with



Fig. 155.

a primer pocket and vent. The initials of the place of manufacture, the number of the month, and the year of its fabrication are stamped on the head of case.

The primer consists of the *cup*, *percussion composition*, *disk of shellacked paper*, and *anvil*. The cup is of gilding metal and contains 0.46 grain of nonfulminate composition composed of tersulphide of antimony, potassium chlorate, and sulphur. A disk of shellacked paper covers the composition to protect it from moisture and to prevent electrolytic action. The anvil is of brass and is assembled over the paper. After the primer is assembled to the case, a drop of shellac is placed on the head of the primer to make the joint waterproof.

The charge is of pyrocellulose composition very similar to the powders used as propelling charges in field and seacoast guns. The grains are cylindrical, single, perforated, and graphited. The normal charge weighs from 47 to 50 grains, varying with the lot of powder used.

The bullet has a core of lead and tin composition inclosed in a jacket of cupro-nickel. It weighs 150 grains, and the point is much sharper and offers less resistance to the air than that of any previous model in the United States service. The bullet is cannellured to receive the crimp of the case, and the base of the bullet is flat. The neck of the case is shellacked before loading, and a pressure of at least 75 pounds is required to seat the bullet in the case; this, with the addition of the above-mentioned crimp, makes the case waterproof.

The cartridge complete weighs about 395.5 grains, its weight varying slightly with variation in the weight of the powder charge.

Five cartridges are packed in a clip.

The CLIP, Fig. 156, consists of the *body* A and the *spring* B, both of brass. On the exterior of the sides of the body are the *stop lugs* C, which seat the clip in its slots in the receiver of the rifle. The top edges of the slides are folded inward, forming flanges, which, fitting into the grooves in the heads, hold the cartridges in place. The spring is secured to the bottom of the body by two sets of *interlocking lips* E. The spring is provided with narrow *tongues* D, which, when the clip is filled, are pressed into the grooves of the outside cartridges, holding the cartridges securely in the clip. The clip body can be used a number of times, but the springs only once.

The gallery practice and dummy clip is provided with a strong bronze spring without tongues.

Sixty ball cartridges in 12 clips are packed in a bandoleer.

The bandoleer is made of olive-drab cloth and contains six pockets, each holding two clips. The clips can be readily taken out by forcing back the fold of the pocket.

The bandoleer is provided with a shoulder strap of olive-drab webbing by which it is carried over the shoulder, and a safety pin is provided to afford an adjustment of its length to suit the convenience of the soldier. When packed, the bandoleer weighs about 3.88 pounds.

In each bandoleer is placed an identification card showing the number of cartridges, the caliber and model of ammunition and rifle, place and date of manufacture, kind and lot of powder, and muzzle velocity. The shop symbols of loaders, inspectors, and packers are also given. In case of defective ammunition this card should be returned with report.

Twelve hundred cartridges are packed in aterneplate-lined packing box, hermetically sealed. Each box contains 20 bandoleers of 60 cartridges each. The packing box measures 34.5 by 9.5 by 8.25 inches and weighs about 100 pounds when filled.

The lid is held to the box by five brass bolts and can be easily removed without the use of tools. Two wire seals connect the cover with the sides of the box.

When the lid is removed, the lining may be torn open by means of a wire handle on the metal cover.

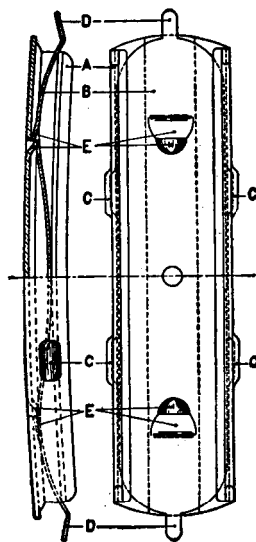

Fig. 156.

A metallic packing chest is also in use. It is made of tinned sheet iron painted olive drab. This chest holds 1,200 cartridges packed in 20 bandoleers of 60 cartridges each. It has a terneplate cover under the lid and is hermetically sealed.

The chest measures 8 by 16½ by 14 inches and weighs about 95 pounds when filled.

A tin seal locks the hasp to the lid. By opening and closing the fold of this seal several times it will break, thus permitting it to be easily withdrawn. When the lid is opened, the cover can be torn off by means of an iron handle attached thereto.

BLANK CARTRIDGE, MODEL OF 1906.

The BLANK CARTRIDGE, model of 1906, Fig. 157, differs from the ball cartridge in the charge of powder and in the bullet and in the fact that the case is tinned. The bullet is of paper, hollow, and contains a charge of 6 grains of "E. C." smokeless powder, which insures the breaking up of the bullet on leaving the bore. This charge is

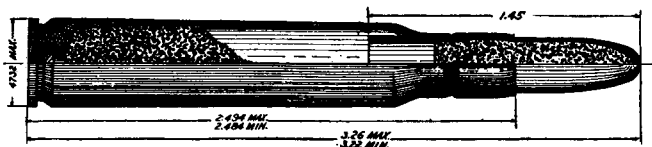

Fig. 157.

retained in the bullet by a drop of shellac. A coating of paraffin on the outside of the bullet prevents the absorption of moisture by the paper. The propelling charge is 10 grains of "E. C." powder.

The cartridge is made 0.1 inch shorter than the ball cartridge. This is a measure of protection against the accidental assembling by the machine of a ball cartridge in a clip of blank ones.

THE BLANK CARTRIDGE, MODEL OF 1909.

In the manufacture of these blank cartridges, Fig. 158, cases are used which have been fired, or which have slight defects, rendering them unsuitable for use in ball cartridges. The charge is 12 grains of "E. C." powder.



Fig. 158.

The case is closed by means of a paper cup inserted in the mouth of the case and shellacked to render the ammunition waterproof.

DUMMY CARTRIDGE.

The case of the DUMMY CARTRIDGE, Fig. 159, is tinned and provided with six longitudinal corrugations, also three circular holes in the corrugated portion.

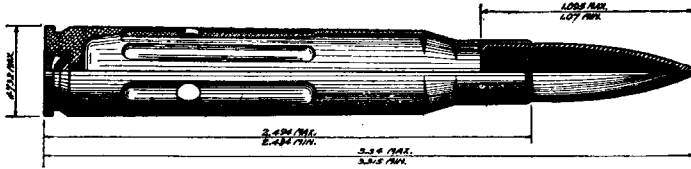

Fig. 159.

The tinning, corrugations, and holes afford unmistakable means for distinguishing the dummy from the ball cartridge, both by sight and touch. The bullet is the same as in the ball cartridge. The dummy primer has cup and anvil, but no percussion composition.

GUARD CARTRIDGE.

This cartridge, Fig. 160, differs from the ball cartridge in the charge of powder and in the fact that second-class bullets having slight

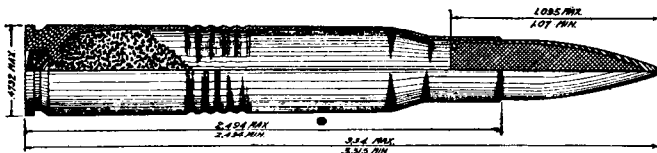

Fig. 160.

imperfections are used. Five cannellures encircle the body of the case at about the middle, affording means for distinguishing it from the ball cartridge by either sight or touch.

The charge, about 9.1 grains bull's-eye powder, or 16.7 grains Du Pont Rifle Smokeless No. 1, gives a muzzle velocity of 1,200 feet per second. This cartridge gives good results at 100 yards and has sufficient accuracy for use at 150 and 200 yards. The range of 100 yards requires a sight elevation of 450 yards, and ranges of 200 and 300 yards require elevations of 650 and 850 yards, respectively.

The guard cartridge, Fig. 161, as now issued, differs from the old issue, Fig. 160, in that six longitudinal corrugations $\frac{3}{16}$ inch long

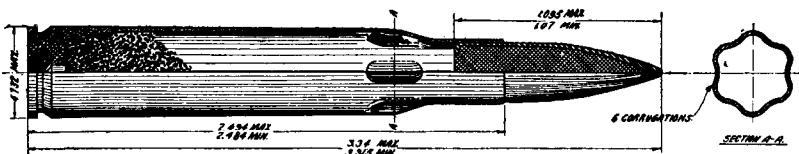

Fig. 161.

start from the shoulder of the case. This affords means of distinguishing this cartridge from the ball cartridge. This cartridge has the same charge of powder, muzzle velocity, etc., as the old issue.

DESCRIPTION OF COLORS AND MARKINGS.

Adopted for the pasteboard and wooden boxes; also the metallic packing chest in which the different kinds of caliber .30 ammunition for the model of 1903 rifle are issued.

Kind of ammunition.	Label on pasteboard box.		Wooden packing box.		Metallic packing chest.	
	Color.	Markings.	Markings.		Markings.	
Ball cartridges, model of 1906. ¹			Red band, 4 inches wide, painted around middle of length and on full length of handles of box.	On both sides of box, the number, kind, model, caliber, kind of powder, and place of manufacture of cartridges; also the model of the rifle; on both ends, the caliber, model, and date, also the lot number, if manufactured under contract; on top, a hand grenade, 5.625 by 2.6875 inches, and "Small-arms ammunition," all in black ink in large figures and letters.	Red band 2 inches wide around middle of length and 3.5 inches length across middle of handle brackets.	On closed end of packing chest, the number, caliber, kind, model of cartridge, model of rifle, kind of powder, and place of manufacture; on lid, the caliber, model of cartridge, and a hand grenade, 5.625 by 2.6875 inches, all in black ink in large figures and letters. Lid marked with month, day, and year the cartridges were loaded, loading-machine number, number of packer, kind of bullet, kind of bandoleer, primer composition, and "Small-arms ammunition" in 0.5-inch figures. Sealing strip with month, day, and year the cartridges were loaded, loading-machine number, number of packer, kind of bullet, kind of bandoleer, and primer composition, with 0.125-inch figures. If manufactured by a contractor, stamp name of contractor and lot number on closed end of packing chest.
Blank cartridges, model of 1906.	Blue....		Blue band, 4 inches wide, painted around box near one end and half of each handle.	On both sides of box, the number, caliber, kind, model, model of rifle, and place of manufacture of cartridges; on both ends of box, the caliber, kind, and model; on cover, a hand grenade, 5.625 by 2.687 (2½) inches, all in black ink, in large figures and letters; both ends of box marked with month, day, and year the cartridges were loaded with 0.5-inch figures stamped with black ink.		

**PRINCIPAL DIMENSIONS AND WEIGHTS OF UNITED STATES RIFLE,
CAL. .30, MODEL OF 1917.**

Barrel:	DIMENSIONS.	Inches.
Diameter of bore.....		0. 30
Exterior diameter at muzzle.....		0. 60
Exterior diameter at breech.....		1. 32
Length of chamber and bore (from face of bolt to muzzle)....		26.
Diameter of chamber, rear end.....		0. 4716
Diameter of chamber, front end.....		0. 442
Diameter of neck of chamber, rear end.....		0. 3425
Diameter of neck of chamber, front end.....		0. 3405
Length of body of chamber.....		1. 785
Length of shoulder of chamber.....		0. 16
Length of neck of chamber.....		0. 396
Length of chamber, total.....		2. 341

Rifling:		
Number of grooves, 5.		
Twist, uniform, left hand, one turn in.....		10.
Width of grooves.....		0. 0936
Width of lands.....		0. 0936
Depth of grooves.....		0. 005
Height of front sight above axis of bore (mean).....		1. 06
Distance from top of front sight to rear side of leaf, leaf raised..		31. 76

Stock:		
Length, with butt plate.....		42. 62
Crook, i. e., distance from axis of bore to heel of butt.....		2. 12
Distance from trigger to butt plate.....		13. 5
Length of gun complete.....		46. 3
Sight radius.....		31. 76
Sight radius (battle sight).....		31. 69

WEIGHTS.

Bayonet.....	1 lb. 2 oz.
Oiler and thong case.....	3 oz.
Total weight of arm with oiler and thong case and bayonet.....	10 lbs. 5 oz.
Total weight of arm with thong case without bayonet.....	9 lbs. 3 oz.
Weight to compress mainspring.....	16 to 18 lbs.
Trigger pull (measured at middle of bow of trigger).....	4½ to 6½ lbs.

MISCELLANEOUS DATA.

Initial velocity.....	2,700 ft. per sec.
Powder pressure in chamber, about.....	51,000 lbs. per sq. in.
Weight of ball cartridge, about.....	395.5 grains.
Weight of bullet.....	150 grains.
Weight of powder charge, about.....	50 grains.

WAR DEPARTMENT,

Office of the Chief of Ordnance,

Washington, January 16, 1918.

OCTOBER 8, 1917.

Revised January 16, 1918.

Form No. 1917.

Ed. Jan. 16-18—20,000.

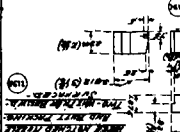
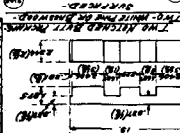
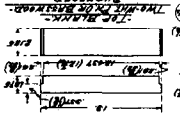
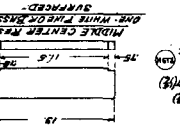
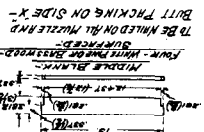
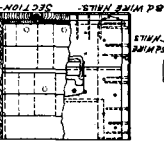
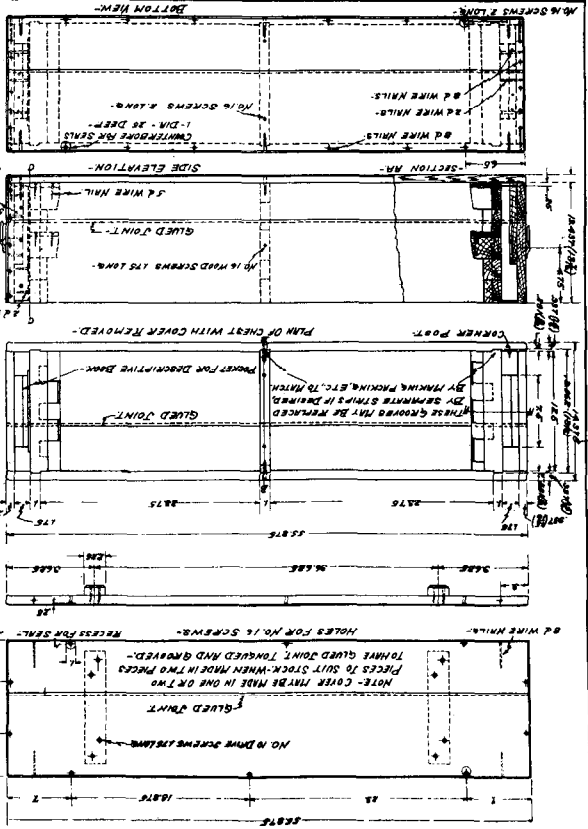

NO.	DESCRIPTION	QTY.
1	COVER	1
2	INSIDE OF CHEST	1
3	PLATE	1
4	BUTT PACKING	1
5	SCREWS	116
6	WIRE NAILS	116
7	GLUE	1

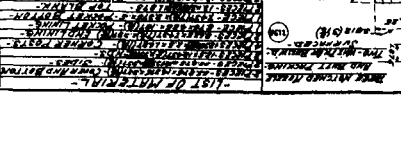
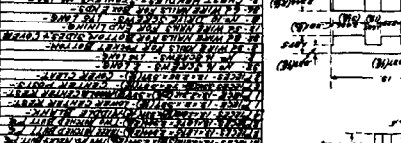
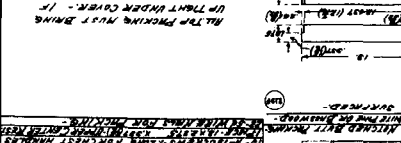
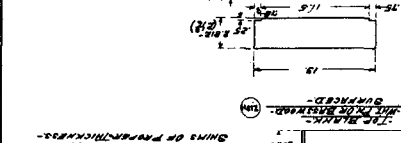
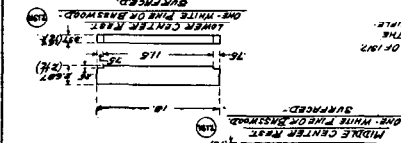

LIST OF MATERIALS

INDEX.

	Page.
Accessories:	
Description	36-37
List	6
Repair, spare parts for	50
Aiming device.....	52-54
Ammunition:	
Cartridges—	
Ball, model of 1906.....	54
Blank, model of 1906.....	56
Blank, model of 1909.....	56
Dummy.....	57
Guard.....	57
Packing, description of colors and markings.....	58-59
Appendages:	
Description	35
List.....	6
Repair, spare parts for	50
Arm chest.....	49
Bandoleer.....	55
Bayonet, model of 1917:	
Component parts.....	6
Description	33
Repair, spare parts for	50
Bayonet scabbard, model of 1917.....	34
Bullet jacket extractor.....	52
Clip.....	55
Dimensions, principal, of rifle.....	60
Miscellaneous data.....	60
Rifle:	
Action of the mechanism.....	38-39
Assembling after dismounting	44
Bolt mechanism—	
Assembling.....	43
Dismounting.....	40
Operation.....	39-40
Cleaning.....	44-48
Component parts.....	5
Description, general.....	7
Description and nomenclature of parts.....	9-33
Dismounting and assembling by soldiers.....	40
Dismounting, complete.....	44
Injuries which do not render parts unserviceable.....	51

Rifle—Continued.

	Page.
Magazine mechanism—	
Assembling.....	43
Dismounting.....	43
Operation.....	39-40
Manipulation by soldier.....	39
Metallic fouling.....	45
Nomenclature.....	9-33
Packing.....	49
Precautions.....	40
Remarks.....	52
Repair—	
Parts most likely to require.....	51
Spare parts for.....	49
Replacing broken parts.....	51
Using when certain parts of bolt and magazine mechanism are wanting....	51
Weights, principal, of rifle.....	60

